

# Cowans Camp Watchfield Oxfordshire



## Archaeological Evaluation



January 2013

**Client: CC Developments LLP**

Issue No: 1  
OA Job No: 5507  
NGR: SU 24178 90390





Client Name: CgMS  
 Client Ref No:  
 Document Title: Cowans Camp, Watchfield, Oxfordshire  
 Document Type: Archaeological Evaluation Report  
 Issue/Version Number: 1  
 Grid Reference: SU 24178 90390  
 Planning Reference:  
 OA Job Number: 5507  
 Site Code: WACW 12  
 Invoice Code: WACWEV  
 Receiving Museum: Oxfordshire County Museums Service  
 Museum Accession No: OXCMS: 2012.153  
 Event No:

Issue	Prepared by	Checked by	Approved by	Signature
1	Steve Leech (Project Officer)	Tim Allen (Senior Project Manager)	Ed Biddulph Senior Project Manager PX	

Document File Location Projects on Server 1: Cowans Camp Watchfield/  
 Graphics File Location Samba-1\invoice codes r thru z\W\_codes\WACWEV\links\Cowan's  
 Camp\HRK\20-12-12  
 Illustrated by Matt Bradley , Leo Heatley and Hannah Kennedy

**Disclaimer:**

*This document has been prepared for the titled project or named part thereof and should not be relied upon or used for any other project without an independent check being carried out as to its suitability and prior written authority of Oxford Archaeology being obtained. Oxford Archaeology accepts no responsibility or liability for the consequences of this document being used for a purpose other than the purposes for which it was commissioned. Any person/party using or relying on the document for such other purposes agrees, and will by such use or reliance be taken to confirm their agreement to indemnify Oxford Archaeology for all loss or damage resulting therefrom. Oxford Archaeology accepts no responsibility or liability for this document to any party other than the person/party by whom it was commissioned.*

© Oxford Archaeological Unit Ltd 2013

Janus House

Osney Mead

Oxford OX2 0ES

t: +44 (0) 1865 263800

e: oasouth@thehumanjourney.net

f: +44 (0) 1865 793496

w: oasouth.thehumanjourney.net

Oxford Archaeological Unit Limited is a Registered Charity No: 285627





# Cowans Camp Watchfield Oxfordshire

## *Archaeological Evaluation Report*

*Written by Steve Leech*

*with contributions from John Cotter, Ian Scott and Louise Loe*

*and illustrated by Hannah Kennedy*

### Table of Contents

**Summary..... 4**

**1 Introduction..... 5**

    1.1 Location and scope of work..... 5

    1.2 Geology and topography..... 5

    1.3 Archaeological and historical background..... 5

    1.4 Acknowledgements..... 5

**2 Evaluation Aims and Methodology..... 6**

    2.1 Aims..... 6

    2.2 Methodology..... 6

**3 Results..... 7**

    3.1 Introduction and presentation of results..... 7

    3.2 General soils and ground conditions..... 7

    3.3 General distribution of archaeological deposits..... 7

    3.4 Insert description title (e.g. Trench 1, or Trenches in Field A, etc.....)..... 7

    3.5 Insert description title (e.g. Trench 2, or Trenches in Field B, etc.....)..... 7

    3.6 Finds summary..... 7

**4 Discussion..... 8**

    4.1 Reliability of field investigation..... 8

    4.2 Evaluation objectives and results..... 8

    4.3 Interpretation..... 8

    4.4 Significance..... 8

**Appendix A. Trench Descriptions and Context Inventory..... 9**



---

<b>Appendix B. Finds Reports.....</b>	<b>10</b>
B.1 Pottery.....	10
<b>Appendix C. Environmental Reports.....</b>	<b>11</b>
C.1 Environmental samples.....	11
<b>Appendix D. Bibliography and References.....</b>	<b>12</b>
<b>Appendix E. Summary of Site Details.....</b>	<b>13</b>



## List of Figures

- Fig. 1 Site location
- Fig. 2 Plan of site and trench locations overlaid on Google satellite map
- Fig. 3 Aerial photograph of the site taken in 1942
- Fig. 4 Representative sections from trenches 1, 5, 23 and 24
- Fig. 5 Plan of Trench 7 and section of feature 702
- Fig. 6 Plans of Trenches 8 and 9 and section of feature 902
- Fig. 7 Plan of Trench 16 and section of feature 1601
- Fig. 8 Plans of trenches 17 and 18 and sections of ditch 1701 and quarry 1705
- Fig. 9 Plan of Trench 24 and section of feature 2402

## List of Plates

- Plate 1 General view along Trench 1, looking
- Plate 2 Feature 702 in Trench 7, looking
- Plate 3 Modern service trench 902, Trench 9, looking
- Plate 4 Ditch 1601 in Trench 16, looking south
- Plate 5 Quarry 1705 in Trench 17, looking
- Plate 6 General view along Trench 23, looking
- Plate 7 General view along Trench 24, with pit 2402 in foreground
- Plate 8 American Air Force graffito on west side of sub-station



## **Summary**

*Between the 3<sup>rd</sup> and the 14<sup>th</sup> of December 2012 Oxford Archaeology carried out an archaeological evaluation at Cowans Camp, Watchfield, Oxfordshire. Twenty-four trenches were located within the proposed development area. Excavation of the trenches confirmed the location of a quarry shown on 19th-century maps, and revealed various features dating to the 20th Century use of the camp, many of which were visible on aerial photographs. These features included various service trenches, two ditches and one pit. No trace of any earlier archaeological activity was observed, either as archaeological features or deposits, or as residual finds.*





## 1 INTRODUCTION

### 1.1 Location and scope of work

- 1.1.1 Oxford Archaeology (OA) was commissioned by CgMs Consulting to undertake a trial trench evaluation at Cowans Camp, Watchfield, Oxfordshire (Fig. 1), prior to determination of a planning application.
- 1.1.2 A Design Brief for Archaeological Field Evaluation was produced by the Oxford County Council Principal Archaeologist Hugh Coddington (November 2012). The brief required an archaeological evaluation in line with Paragraph 128 of the NPPF (2012).
- 1.1.3 All work was undertaken in accordance with local and national planning policies.

### 1.2 Geology and topography

- 1.2.1 The site of the proposed development is located on the north-west side of Watchfield immediately to the east of the A420 (NGR SU 24178 90390).
- 1.2.2 The northern part of the site contains a former military compound. This is an area of hardstanding with one large building still standing in the centre, and four smaller buildings still standing on the south-west, west, north-west and north-east sides (see Figure 2). The rest of the site is pasture.
- 1.2.3 The geology is Stanford Limestone and the site slopes gently southwards from approximately 105m OD to 98m OD. The south-west corner of the site is only 100m from the Tuckmill Brook, which runs east-south-east.

### 1.3 Archaeological and historical background

- 1.3.1 The archaeological and historical background to the site has been described in detail in an Archaeological Desk Based Assessment (HeritageCollective 2012). The results are summarised below.
- 1.3.2 An unstratified Palaeolithic handaxe was found adjacent to Acorn Way to the south-west of the site (MOX9459).
- 1.3.3 Late Mesolithic or early Neolithic activity was noted during archaeological investigations at the Joint Service Command and Staff College, 0.5km north-east of the site (EOX393, EOX394, EOX1612, EOX1895). This included a segmented ditch and residual flintwork suggesting a possible area of settlement (MOX23216).
- 1.3.4 A scatter of flint arrowheads, cores, scrapers and flakes dating to the late Neolithic or early Bronze Age was uncovered 750m south-east of the site (MOX10172).
- 1.3.5 During investigations at the Joint Service Command and Staff College, (see above), a complex series of intercutting ditches representing an Early to Middle Iron Age enclosure was uncovered (MOX23217). Large quantities of cattle bone from both pits and the enclosure ditches perhaps indicates a pastoral economy, and the presence of two double inhumations and a pit containing a trepanned human skull alongside a cattle skull suggests funerary, and possibly other ritual, activity.
- 1.3.6 Excavations for the Joint Service Command and Staff College also revealed Late Iron Age occupation (MOX23218). A sub-rectangular ditched enclosure measuring 50m by 33m, 10 pits and an associated driveway were dated to the 1st century BC/early 1st century AD (Birbeck 2001, 232). A second area of activity was found further south, represented by ditches, postholes and a good assemblage of pottery.



- 1.3.7 The Late Iron Age site continued into the Roman period, with enclosures and field systems similar in form and character to those of the Late Iron Age described above (MOX23218, MOX23219). Animal bones and crop processing suggest a mixed farming economy, and there was also evidence for on-site metalworking.
- 1.3.8 A Roman building, a well and a cemetery were excavated in antiquity some 1.5km east of the site, and Roman activity was also found at Watchfield Triangle 500m east of the site (Biddulph pers. Comm.).
- 1.3.9 A Scheduled Ancient Monument (SAM 20602), defining the site of a 5th century Saxon cemetery, lies 500m to the east. Magnetometry surveys (EOX1404, EOX1405) conducted in the fields adjoining the site have revealed probable further graves, suggesting that as many as 180 graves remain unexcavated.
- 1.3.10 The site lies within the historic parish of Shrivenham within Shrivenham hundred. Shrivenham was mentioned in Domesday as being held by the King, and Watchfield was held by the abbey of Abingdon prior to 1066 (Morris 1976). This suggests that these local settlements have been in existence since at least the 11th century.
- 1.3.11 A second Scheduled Ancient Monument (SAM 28963), comprising the site of a deserted medieval village at Fresden Farm, lies 2km north-west of the site. This site has not been investigated.
- 1.3.12 Documentary evidence suggests that a deserted medieval village (DMV) existed at Beckett Park, now part of the Royal Military College of Science, some 1km south of the site (MOX9441). While some sherds of 13th century pottery were recovered, no physical remains of the DMV have been found on the ground or in aerial photographs.
- 1.3.13 Further medieval occupation was uncovered at the Watchfield Triangle (EOX1331) 500m to the east of the site. Evidence of ridge and furrow, pits and ditches were uncovered dating to the 12th to 14th centuries (MOX11208).
- 1.3.14 The church of St Thomas has medieval origins (MOX10124), and lies only 150 m to the east.
- 1.3.15 Map regression (HeritageCollective 2012, Appendix 3) indicates that the study site was open fields until the early 19th century. Greenwood's map of Berkshire, dated 1829, may indicate three buildings along the eastern edge (indicated by black squares), but there is no detail.
- 1.3.16 The 1868-9 OS map shows a probable quarry within the site, just south of centre (see also Figure 2). This was infilled by the time the 1898 OS map was drawn. Another quarry is marked extending into the north-west corner of the site on the OS map of 1910. This was of limited extent, but was still visible until 1942, as is shown on an aerial photograph of that date. This aerial photograph also shows various cropmark features north and west of the site, whose date and purpose is uncertain (see Figure 3).
- 1.3.17 The northern part of the site was taken over in the 1940s by a military enclosure, which still survives. A small brick building in the south-east corner of the field also dates from this time.

## 1.4 Acknowledgements

- 1.4.1 The evaluation was managed by Tim Allen for Oxford Archaeology, and was undertaken by Steve Leech, Ben McAndrew, Ben Slader and Al Zochowski on behalf of CgMs consulting. We are also grateful to Hugh Coddington of Oxfordshire County Council for enabling the archaeological work to take place.



## 2 EVALUATION AIMS AND METHODOLOGY

### 2.1 Aims

- (i) To determine the presence or absence of any archaeological remains which may survive.
- (ii) To determine or confirm the approximate extent of any surviving remains
- (iii) To determine the date range of any surviving remains by artefactual or other means.
- (iv) To determine the condition and state of preservation of any remains.
- (v) To determine the degree of complexity of any surviving horizontal or vertical stratigraphy.
- (vi) To assess the associations and implications of any remains encountered with reference to the historic landscape.
- (vii) To determine the potential of the site to provide palaeo-environmental and/or economic evidence, and the forms in which such evidence may survive.
- (viii) To determine the implications of any remains with reference to economy, status, utility and social activity.
- (ix) To determine or confirm the likely range, quality and quantity of the artefactual evidence present.

### 2.2 Specific Aims and Objectives

2.2.1 The specific aims and objectives of the evaluation were:

- (x) To establish whether there is any change in the soil sequence across the site, and in particular, whether proximity to the Tuckmill Stream on the south has influenced the character of the soils at this end of the site.
- (xi) To determine whether the possible structures marked on the 1829 map were indeed buildings, and if so, of what character.
- (xii) To confirm the location of the mid-19th century quarry marked on the OS map of 1868-9

### 2.3 Methodology

2.3.1 The overall site was 9.7 ha in area but the illustrative masterplan (Drawing BDA 146/SK01G) identifies areas of open grass and areas of development. The development area is approximately 6.4 ha.

2.3.2 A 2% sample evaluation of the proposed development area, equivalent to twenty seven 30m x 1.6m trenches, was requested in the Archaeological Design Brief prepared by Hugh Coddington across the part of the site that is identified for development on Drawing BDA146/SK01G.

2.3.3 The trench layout is shown in Figure 2. As there are standing buildings on the north part of the site, the areas covered by these buildings were not included in the areas proposed for trenching.

2.3.4 Due to the presence of great crested newts on the site, whose hibernation habitats could not be disturbed, the area of scrubland in the middle of the site was not



evaluated at this time. This meant that trenches 11, 13 and 14 could not be excavated (see Figure 2). A total of 24 trenches therefore constituted this phase of evaluation, providing a 2% sample of the area excluding the newt hibernation zone.

- 2.3.5 Trench 17 was divided into two, as it crossed the likely position of the 19th century quarry. The limits of the quarry shown on the 1910 OS map lie outside the development area.
- 2.3.6 Trench 2 was also split into two halves due to the presence of a gas main and other services in the northern area of the site.
- 2.3.7 The area of each trench, plus strips either side where spoil was to be deposited, was finger-tip searched by a qualified ecologist to check for newts before mechanical excavation began.
- 2.3.8 Trenches were excavated and backfilled using a JCB with toothless ditching bucket, in accordance with the ecological requirements. Ramps were excavated at both ends of every trench to allow egress for newts.
- 2.3.9 Open trenches were inspected for newts every morning before work commenced.
- 2.3.10 Except where specifically stated in the Written Scheme of Investigation (OA 2012), all archaeological work was carried out in accordance with the Oxford Archaeology Fieldwork Manual (ed. Wilkinson 1992).
- 2.3.11 Mechanical excavation was carried out under the supervision of a competent archaeologist either to the top of 'natural' or the top of any significant archaeological level, whichever was the higher. Care was taken not to damage archaeological deposits through excessive use of mechanical excavation.
- 2.3.12 Spoil was scanned during excavation, and a metal detector used to scan the excavated soil for finds.
- 2.3.13 The surface of the exposed archaeological horizon was cleaned where necessary to clarify the extent and character of any archaeological remains.
- 2.3.14 Archaeological features were sampled sufficiently to characterise and date them. Full excavation of features was not undertaken at this stage.

## 3 RESULTS

### 3.1 Introduction and presentation of results

3.1.1 The following section summarises the results of the evaluation. The location of the trenches is shown on Figure 2, and the details of those trenches containing features in Figures 3 to 8 and Plates 1-7. Detailed archaeological descriptions are presented in the context inventory (Appendix A), and are referred to in the descriptive text where relevant.

### 3.2 General soils and ground conditions

3.2.1 All the trenches located on grassland within the southern area of the site consisted of a dark grey / brown topsoil 0.20m to 0.30m thick, overlying a natural consisting of limestone or a grey / brown 'cornbrash', made up of clay with limestone inclusions.

3.2.2 The trenches located on the hard-standing surface consisted of modern made ground overlying the natural limestone / cornbrash.

3.2.3 The trenches were opened up in dry conditions, allowing clear observation of any potential archaeological features.

### 3.3 General distribution of archaeological deposits

3.3.1 Various service trenches were located within trenches 2, 3, 8, 9, 15, 17 and 20. A single small pit was found in trench 24, a NW-SE orientated ditch in trench 7, and a N-S ditch in trench 16. The 19th century quarry visible on historic maps and from the air was located in trenches 17 and 18.

### 3.4 Trench 1 (Fig. 4 and Plate 1)

3.4.1 Trench 1 was orientated NE-SW, was 1.6m wide and was only 25m long, due to the proximity of gas services and a road. The trench consisted of 0.3m of topsoil overlying the natural limestone / cornbrash, and was devoid of archaeology.

### 3.5 Trench 2a

3.5.1 Trench 2a was orientated NE-SW, was 1.6m wide and was 15m long. The trench was devoid of any archaeology, and consisted of 0.3m of topsoil overlying the natural limestone / cornbrash.

### 3.6 Trench 2b

3.6.1 Trench 2b was orientated NW-SW, was 1.6m wide and was 15m long, and contained a modern service trench at the south-western end. The trench contained of 0.3m of Made Ground overlying the natural limestone / cornbrash, and was devoid of any archaeological features.

### 3.7 Trench 3

3.7.1 Trench 3 was orientated NW-SE, was 1.6m wide and was only 25m long, due to the presence of various modern services at either end of the trench. The trench consisted of 0.3m of Made Ground overlying the natural limestone / cornbrash. Below the Made Ground there were two modern service trenches and an area of deeper disturbed ground.



### **3.8 Trench 4**

3.8.1 Trench 4 was orientated NE-SW and was 1.6m wide and 30m long. The trench contained 0.28m of topsoil overlying the natural limestone / cornbrash. There was no evidence of archaeological activity.

### **3.9 Trench 5 (Fig. 4)**

3.9.1 Trench 5 was orientated NW-SE and was 1.6m wide and 30m long. It consisted of 0.20m of made ground overlying the natural limestone / cornbrash, and was devoid of archaeological features.

### **3.10 Trench 6**

3.10.1 Trench 6 was orientated NE-SW and was 1.6m wide and 30m long. The trench contained 0.30m of Made Ground overlying the natural limestone / cornbrash, and was devoid of archaeological remains.

### **3.11 Trench 7 (Fig. 5 and Plate 2)**

3.11.1 Trench 7 was orientated NW-SE, 1.6m wide and 30m long. Topsoil was 0.3m thick and overlay the natural limestone/cornbrash and a single ditch [702] orientated east – west. Ditch 702 was 1.2m wide and 0.35m deep, with a concave base and moderately sloping sides. It contained two fills, a dark brown sandy loam 0.05m thick (704) overlain by a brown sandy loam 0.3m thick (703), which contained fragments of corroded iron.

### **3.12 Trench 8**

3.12.1 Trench 8 was orientated E-W and was 1.6m wide and 30m long. The natural limestone/ cornbrash was overlain by 0.25m of Made Ground. Cut into the natural was a recent service trench oriented WNW, on the same line and alignment as the modern service trench in trench 9 (see below). This service trench is also visible as a dark linear mark on the Google satellite view of the site (Figure 2). There were no archaeological features or finds.

### **3.13 Trench 9 (Fig. 6 and Plate 3)**

3.13.1 Trench 9 was orientated NE-SW and was 1.6m wide and 30m long. It contained 0.25m of Made Ground overlying the natural limestone/ cornbrash, which was cut by a modern service trench aligned WNW, which was also picked up in Trench 8 (see above). This service trench, [902], was excavated to a depth of 0.82m, but was not bottomed. It had vertical sides and contained a single fill of limestone rubble containing fragments of ceramic building material (hereafter CBM), glass and roof slate. There were no other features or finds.

### **3.14 Trench 10**

3.14.1 Trench 10 was orientated NE-SW and was 1.6m wide and 30m long. The trench consisted of 0.30m of topsoil overlying the natural limestone / cornbrash, and was devoid of archaeology.

### **3.15 Trench 12**

3.15.1 Trench 12 was orientated NW-SE and was 1.6m wide and 30m long. The trench contained 0.25m of topsoil overlying the natural limestone / cornbrash. There were no archaeological features or finds.



### **3.16 Trench 15**

3.16.1 Trench 15 was orientated NW-SE and was 1.6m wide and 30m long. Topsoil was 0.3m deep and overlay the natural limestone / cornbrash. At the south-eastern end of the trench the natural was cut by two parallel modern service trenches orientated NNE-SSW. These were not excavated.

### **3.17 Trench 16 (Fig. 7 and Plate 4)**

3.17.1 Trench 16 was orientated N-S and was 1.6m wide and 30m long. This trench contained the greatest accumulation of topsoil within the evaluated area, up to 0.4m deep. The topsoil overlay the natural limestone/ cornbrash, which was cut by a ditch running N-S along the length of the trench. Ditch [1601] was 1m wide and 0.2m deep, with a concave base and shallow sloping sides. It contained a grey silty clay 0.1m thick (1604) overlain by a dark brown sandy clay (1602), neither of which produced any finds.

### **3.18 Trench 17 (Fig. 8 and Plate 5)**

3.18.1 Trench 17 was positioned to confirm the location of the edges of a 19th-century quarry shown on historic maps, whose position was also indicated by a change in the vegetation on a recent aerial photograph (see Figure 2). The trench was therefore split into two to straddle both edges of the quarry. In total it was 30m long and 1.6m wide.

3.18.2 The sides of the quarry were found to dip quite gently; no attempt was made to reach the base. Quarry [1705] was 11m wide and two fills were exposed, the lower (1703) being a brown sandy silt with frequent stone inclusions, which was excavated to a depth of nearly 0.4m. Above this was a light brown sand with frequent stone inclusions (1704), again excavated to a depth of 0.4m.

3.18.3 At the north-eastern end of the trench a modern ditch [1701] cut the fills of the quarry. This had vertical sides, and was excavated to a depth of 0.4m, but was not bottomed. The ditch, the quarry and the natural limestone were overlain by a layer of topsoil 0.3m thick.

### **3.19 Trench 18 (Fig. 8)**

3.19.1 Trench 18 was orientated NE-SW and was 1.6m wide and 30m long and was targeted on the same quarry as Trench 17. Quarry 1802 extended 9.5m from the north-eastern end of the trench was filled by 1801, a brown sandy silt which contained no finds. This deposit was not bottomed. This was overlain by a layer of topsoil 0.3m thick, which came down directly onto the natural limestone/ cornbrash south of the quarry. No archaeological features or finds were discovered.

### **3.20 Trench 19**

3.20.1 Trench 19 was orientated N-S and was 1.6m wide and 30m long. The stratigraphy consisted of 0.3m of topsoil overlying the natural limestone / cornbrash. The trench was devoid of archaeology.

### **3.21 Trench 20**

3.21.1 Trench 20 was orientated NE-SW, and was 1.6m wide and 30m long. Topsoil was 0.24m deep, and directly overlay the natural limestone/ cornbrash, except at the south-western end of the trench, where there was a modern service trench cutting the natural. This was not excavated, but appears likely to have been a continuation of one of the service trenches seen in Trench 15. No other features or finds were present.



### **3.22 Trench 21**

3.22.1 Trench 21 was orientated NW-SE and was 1.6m wide and 30m long. The trench contained 0.25m of topsoil overlying the natural limestone / cornbrash, and was devoid of archaeology.

### **3.23 Trench 22**

3.23.1 Trench 22 was orientated N-S and was 1.6m wide and 30m long. Like Trench 21, topsoil was 0.25m deep and directly overlay the natural limestone / cornbrash. There were no archaeological features or finds.

### **3.24 Trench 23 (Fig. 4)**

3.24.1 Trench 23 was orientated E-W and was 1.6m wide and 30m long. Topsoil was 0.25m deep, and directly overlay the natural limestone / cornbrash. No archaeological features or finds were present.

### **3.25 Trench 24 (Figs 4 and 9 and Plate 7)**

3.25.1 Trench 24 was orientated NW-SE and was 1.6m wide and 30m long. Topsoil was 0.3m thick. This overlay the natural limestone/ cornbrash, and also a single pit [2402] cut into the natural. The pit was circular in plan, 1m in diameter, and was 0.34m deep with steep sides and a flattish bottom. It contained two fills, a dark brown silty clay with occasional small limestone fragments (2403) overlain by an off-white limestone rubble backfill (2404). Neither deposit contained any finds.

### **3.26 Trench 25**

3.26.1 Trench 25 was orientated E-W and was 1.6m wide and 30m long. The trench contained a layer of topsoil 0.25m deep that directly overlay the natural limestone / cornbrash. There were no archaeological features or finds.

### **3.27 Trench 26**

3.27.1 Trench 26 was orientated NW-SE and was 1.6m wide and 30m long. As in Trench 25, topsoil was 0.25m deep and directly overlay the natural limestone / cornbrash, and the trench was devoid of archaeology.

### **3.28 Trench 27**

3.28.1 Trench 27 was orientated E-W and was 1.6m wide and 30m long. Like Trenches 25 and 26, there were no archaeological features or finds, topsoil 0.25m deep directly overlying the natural limestone / cornbrash.

### **3.29 Finds summary**

3.29.1 The only artefacts recovered from site were fragments of iron from (703), the upper fill of ditch [702], and fragments of modern glass, CBM, roof slate and a residual sherd of Medieval pottery from (901), the fill of modern service trench [902].

3.29.2 As all of the features appeared to be of modern date, no environmental samples were taken.





## 4 DISCUSSION

### 4.1 Reliability of field investigation

- 4.1.1 The machining and recording of the trenches was carried out in dry conditions. There was nothing that might have biased or prejudiced the evidence from the evaluation.

### 4.2 Evaluation objectives and results

- 4.2.1 There was very little change in the soil sequence over the site. It consisted of a topsoil / ploughsoil overlying weathered clay with limestone fragments (cornbrash) or (in the southwestern area of the site) less weathered limestone.
- 4.2.2 The trenches located on the hardstanding within the compound and around the buildings showed that the topsoil had been removed and the modern hardstanding laid directly on-top of the natural cornbrash.
- 4.2.3 There was no evidence of any of the possible structures marked on the 1829 map at the east side of the site, although the area of these structures may in part lie within the unevaluated newt hibernation area.
- 4.2.4 Trenches 17 and 18 confirmed the location of the mid-19th century quarry marked on the OS map of 1868-9. Additionally the modern ditch seen in trench 17 can be seen as a field boundary on various aerial photographs from 1942 to 1997.
- 4.2.5 Trenches 2b and 3 contained existing services for the up-standing buildings nearby.
- 4.2.6 The ditch in trench 7 is also visible as an extant field boundary on aerial photographs dating from 1942 to 1968.
- 4.2.7 The modern service trench seen in trenches 8 and 9 is visible as a cropmark on the most recent Google satellite image of the site (see Figure 2).
- 4.2.8 The only features within trenches 15 and 20 are also visible on the 1942 aerial photograph (see Figure 3), and like the other service trenches, contained a very similar crushed limestone fill. These also presumably belong to the 20<sup>th</sup> Century use of the site. The small undated pit in Trench 24 also had a similar upper fill, and this too is likely to date from the period of the former Army camp.
- 4.2.9 The only feature possibly of earlier date is the ditch running along the length of trench 16. This is however very close to the current boundary of the field, and runs parallel to it, so is probably a post-medieval former drainage ditch.
- 4.2.10 One item of WWII interest is the grafitto scratched on the western wall of the sub-station located in the south-eastern corner of the field. This reads "12 DEC 1944 AD USAF IS WAS HERE". (see Plate 8).

### 4.3 Interpretation

- 4.3.1 All the features present in the trenches are probably associated to the 20th Century use of the site from its establishment during World War II up-to it's closure in the 1970s. Apart from a single sherd of medieval pottery, no evidence of activity earlier than this date was recovered. The medieval sherd was probably the result of manuring during the late medieval or post-medieval period, when historic maps show that the field was part of the strip field system of the village.



## APPENDIX A. TRENCH DESCRIPTIONS AND CONTEXT INVENTORY

Trench 1						
<b>General description</b>				<b>Orientation</b>		NW-SE
Trench devoid of archaeology. Consists of topsoil overlying a natural of limestone and cornbrash.				<b>Avg. depth (m)</b>		0.3
				<b>Width (m)</b>		1.6
				<b>Length (m)</b>		25
Contexts						
context no	type	Width (m)	Depth (m)	comment	finds	date
100	Layer	-	0.3	Topsoil	-	-
101	Layer	-	-	Natural	-	-

Trench 2a						
<b>General description</b>				<b>Orientation</b>		NW-SE
Trench devoid of archaeology. Consists of topsoil overlying a natural of limestone and cornbrash.				<b>Avg. depth (m)</b>		0.3
				<b>Width (m)</b>		1.6
				<b>Length (m)</b>		15
Contexts						
context no	type	Width (m)	Depth (m)	comment	finds	date
200	Layer	-	0.3	Topsoil	-	-
201	Layer	-	-	Natural	-	-

Trench 2b						
<b>General description</b>				<b>Orientation</b>		NE-SW
Trench devoid of archaeology. Consists of topsoil overlying a natural of limestone and cornbrash.				<b>Avg. depth (m)</b>		0.3
				<b>Width (m)</b>		1.6
				<b>Length (m)</b>		15
Contexts						
context no	type	Width (m)	Depth (m)	comment	finds	date
202	Layer	-	0.3	Topsoil	-	-
203	Cut	-	-	Modern service trench	-	-
204	Layer	-	-	Natural	-	-



Trench 3						
<b>General description</b>				<b>Orientation</b>		NW-SE
Trench devoid of archaeology. Consists of modern made ground overlying a natural of limestone and cornbrash.				<b>Avg. depth (m)</b>		0.3
				<b>Width (m)</b>		1.6
				<b>Length (m)</b>		25
Contexts						
context no	type	Width (m)	Depth (m)	comment	finds	date
301	Layer	-	0.3	Topsoil	-	-
300	Layer	-	-	Natural	-	-

Trench 4						
<b>General description</b>				<b>Orientation</b>		NE-SW
Trench devoid of archaeology. Consists of topsoil overlying a natural of limestone and cornbrash.				<b>Avg. depth (m)</b>		0.28
				<b>Width (m)</b>		1.6
				<b>Length (m)</b>		30
Contexts						
context no	type	Width (m)	Depth (m)	comment	finds	date
400	Layer	-	0.28	Topsoil	-	-
401	Layer	-	-	Natural	-	-

Trench 5						
<b>General description</b>				<b>Orientation</b>		NW-SE
Trench devoid of archaeology. Consists of topsoil overlying a natural of limestone and cornbrash.				<b>Avg. depth (m)</b>		0.2
				<b>Width (m)</b>		1.6
				<b>Length (m)</b>		30
Contexts						
context no	type	Width (m)	Depth (m)	comment	finds	date
500	Layer	-	0.2	Topsoil	-	-
501	Layer	-	-	Natural	-	-



Trench 6						
<b>General description</b>				<b>Orientation</b>	NE-SW	
Trench devoid of archaeology. Consists of topsoil overlying a natural of limestone and cornbrash.				<b>Avg. depth (m)</b>	0.3	
				<b>Width (m)</b>	1.6	
				<b>Length (m)</b>	30	
Contexts						
context no	type	Width (m)	Depth (m)	comment	finds	date
600	Layer	-	0.3	Topsoil	-	-
601	Layer	-	-	Natural	-	-

Trench 7						
<b>General description</b>				<b>Orientation</b>	NW-SE	
Trench containing a single E-W ditch. Consists of topsoil overlying a natural of limestone and cornbrash.				<b>Avg. depth (m)</b>	0.3	
				<b>Width (m)</b>	1.6	
				<b>Length (m)</b>	30	
Contexts						
context no	type	Width (m)	Depth (m)	comment	finds	date
700	Layer	-	0.3	Topsoil	-	-
702	Cut	1.2	0.35	Ditch	-	-
703	Fill	1.2	0.3	Ditch fill	Metal	Modern
704	Fill	0.7	0.05	Ditch fill	-	-
701	Layer	-	-	Natural	-	-

Trench 8						
<b>General description</b>				<b>Orientation</b>	E-W	
Trench devoid of archaeology. Consists of topsoil overlying a natural of limestone and cornbrash.				<b>Avg. depth (m)</b>	0.25	
				<b>Width (m)</b>	1.6	
				<b>Length (m)</b>	30	
Contexts						
context no	type	Width (m)	Depth (m)	comment	finds	date
800	Layer	-	0.25	Topsoil	-	-
802	Cut	-	-	Modern service trench	-	-
803	Fill	-	-	Modern service trench fill	-	-
801	Layer	-	-	Natural	-	-



Trench 9						
<b>General description</b>					<b>Orientation</b>	NE-SW
Trench devoid of archaeology. Consists of topsoil overlying a natural of limestone and cornbrash.					<b>Avg. depth (m)</b>	0.4
					<b>Width (m)</b>	1.6
					<b>Length (m)</b>	30
Contexts						
context no	type	Width (m)	Depth (m)	comment	finds	date
900	Layer	-	0.4	Topsoil	-	-
901	Fill	0.6	0.82	Modern service trench fill	-	-
902	Cut	0.6	0.82	Modern service trench	-	-
903	Layer	-	-	Natural		

Trench 10						
<b>General description</b>					<b>Orientation</b>	NE-SW
Trench devoid of archaeology. Consists of topsoil overlying a natural of limestone and cornbrash.					<b>Avg. depth (m)</b>	0.3
					<b>Width (m)</b>	1.6
					<b>Length (m)</b>	30
Contexts						
context no	type	Width (m)	Depth (m)	comment	finds	date
1000	Layer	-	0.3	Topsoil	-	-
1001	Layer	-	-	Natural	-	-

Trench 12						
<b>General description</b>					<b>Orientation</b>	NW-SE
Trench devoid of archaeology. Consists of topsoil overlying a natural of limestone and cornbrash..					<b>Avg. depth (m)</b>	0.25
					<b>Width (m)</b>	1.6
					<b>Length (m)</b>	30
Contexts						
context no	type	Width (m)	Depth (m)	comment	finds	date
1200	Layer	-	0.25	Topsoil	-	-
1201	Layer	-	-	Natural	-	-



<b>Trench 15</b>						
<b>General description</b>				<b>Orientation</b>	NW-SE	
Trench devoid of archaeology. Consists of topsoil overlying a natural of limestone and cornbrash.				<b>Avg. depth (m)</b>	0.3	
				<b>Width (m)</b>	1.6	
				<b>Length (m)</b>	30	
<b>Contexts</b>						
context no	type	Width (m)	Depth (m)	comment	finds	date
1500	Layer	-	0.3	Topsoil	-	-
1501	Layer	-	-	Natural	-	-

<b>Trench 16</b>						
<b>General description</b>				<b>Orientation</b>	N-S	
Trench contains a single NE-SW ditch. Consists of topsoil overlying a natural of limestone and cornbrash.				<b>Avg. depth (m)</b>	0.4	
				<b>Width (m)</b>	1.6	
				<b>Length (m)</b>	30	
<b>Contexts</b>						
context no	type	Width (m)	Depth (m)	comment	finds	date
1600	Layer	-	0.4	Topsoil	-	-
1601	Cut	1	0.2	Ditch	-	-
1602	Fill	1	0.1	Ditch fill	-	-
1604	Fill	0.7	0.1	Ditch fill	-	-
1603	Layer	-	-	Natural	-	-



<b>Trench 17</b>						
<b>General description</b>				<b>Orientation</b>	NE-SW	
Trench contains Post-Medieval Quarry cut by a ditch. Consists of topsoil overlying a natural of limestone and cornbrash.				<b>Avg. depth (m)</b>	0.3	
				<b>Width (m)</b>	1.6	
				<b>Length (m)</b>	30	
<b>Contexts</b>						
<b>context no</b>	<b>type</b>	<b>Width (m)</b>	<b>Depth (m)</b>	<b>comment</b>	<b>finds</b>	<b>date</b>
1700	Layer	-	0.28	Topsoil	-	-
1701	Cut	-	0.22	Modern ditch	-	-
1702	Fill	-	-	Modern ditch fill	-	-
1703	Fill			Quarry fill	-	-
1704	Fill			Quarry fill	-	-
1705	Cut			Quarry	-	-
1706	Layer			Natural	-	-

<b>Trench 18</b>						
<b>General description</b>				<b>Orientation</b>	NE-SW	
Trench contains Post-Medieval Quarry. Consists of topsoil overlying a natural of limestone and cornbrash.				<b>Avg. depth (m)</b>	0.25	
				<b>Width (m)</b>	1.6	
				<b>Length (m)</b>	30	
<b>Contexts</b>						
<b>context no</b>	<b>type</b>	<b>Width (m)</b>	<b>Depth (m)</b>	<b>comment</b>	<b>finds</b>	<b>date</b>
1800	Layer	-	0.25	Topsoil	-	-
1801	Fill	-	0.1	Quarry fill	-	-
1802	Cut	1.6	0.1	Quarry	-	-
1803	Layer	-	-	Natural		



Trench 19						
<b>General description</b>				<b>Orientation</b>	N-S	
Trench devoid of archaeology. Consists of topsoil overlying a natural of limestone and cornbrash.				<b>Avg. depth (m)</b>	0.3	
				<b>Width (m)</b>	1.6	
				<b>Length (m)</b>	30	
Contexts						
context no	type	Width (m)	Depth (m)	comment	finds	date
1901	Layer	-	0.3	Topsoil	-	-
1900	Layer	-	-	Natural	-	-

Trench 20						
<b>General description</b>				<b>Orientation</b>	NE-SW	
Trench devoid of archaeology. Consists of topsoil overlying a natural of limestone and cornbrash.				<b>Avg. depth (m)</b>	0.24	
				<b>Width (m)</b>	1.6	
				<b>Length (m)</b>	30	
Contexts						
context no	type	Width (m)	Depth (m)	comment	finds	date
2001	Layer	-	0.24	Topsoil	-	-
2000	Layer	-	-	Natural	-	-

Trench 21						
<b>General description</b>				<b>Orientation</b>	NW-SE	
Trench devoid of archaeology. Consists of topsoil overlying a natural of limestone and cornbrash.				<b>Avg. depth (m)</b>	0.25	
				<b>Width (m)</b>	1.6	
				<b>Length (m)</b>	30	
Contexts						
context no	type	Width (m)	Depth (m)	comment	finds	date
2101	Layer	-	0.25	Topsoil	-	-
2100	Layer	-	-	Natural	-	-





Trench 22						
<b>General description</b>				<b>Orientation</b>	N-S	
Trench devoid of archaeology. Consists of topsoil overlying a natural of limestone and cornbrash.				<b>Avg. depth (m)</b>	0.25	
				<b>Width (m)</b>	1.6	
				<b>Length (m)</b>	30	
Contexts						
context no	type	Width (m)	Depth (m)	comment	finds	date
2201	Layer	-	0.25	Topsoil	-	-
2200	Layer	-	-	Natural	-	-

Trench 23						
<b>General description</b>				<b>Orientation</b>	E-W	
Trench devoid of archaeology. Consists of topsoil overlying a natural of limestone and cornbrash.				<b>Avg. depth (m)</b>	0.25	
				<b>Width (m)</b>	1.6	
				<b>Length (m)</b>	30	
Contexts						
context no	type	Width (m)	Depth (m)	comment	finds	date
2301	Layer	-	0.25	Topsoil	-	-
2300	Layer	-	-	Natural	-	-

Trench 24						
<b>General description</b>				<b>Orientation</b>	NW-SE	
Trench containing single pit. Consists of topsoil overlying a natural of limestone and cornbrash.				<b>Avg. depth (m)</b>	0.3	
				<b>Width (m)</b>	1.6	
				<b>Length (m)</b>	30	
Contexts						
context no	type	Width (m)	Depth (m)	comment	finds	date
2400	Layer	-	0.3	Topsoil	-	-
2402	Cut	1	0.34	Pit	-	-
2403	Fill	0.8	0.14	Pit fill	-	-
2404	Fill	1	0.2	Pit fill		
2401	Layer	-	-	Natural		



Trench 25						
<b>General description</b>				<b>Orientation</b>	E-W	
Trench devoid of archaeology. Consists of topsoil overlying a natural of limestone and cornbrash.				<b>Avg. depth (m)</b>	0.25	
				<b>Width (m)</b>	1.6	
				<b>Length (m)</b>	30	
Contexts						
context no	type	Width (m)	Depth (m)	comment	finds	date
2501	Layer	-	0.25	Topsoil	-	-
2500	Layer	-	-	Natural	-	-

Trench 26						
<b>General description</b>				<b>Orientation</b>	NW-SE	
Trench devoid of archaeology. Consists of topsoil overlying a natural of limestone and cornbrash.				<b>Avg. depth (m)</b>	0.3	
				<b>Width (m)</b>	1.6	
				<b>Length (m)</b>	30	
Contexts						
context no	type	Width (m)	Depth (m)	comment	finds	date
2601	Layer	-	0.3	Topsoil	-	-
2600	Layer	-	-	Natural	-	-

Trench 27						
<b>General description</b>				<b>Orientation</b>	E-W	
Trench devoid of archaeology. Consists of topsoil overlying a natural of limestone and cornbrash.				<b>Avg. depth (m)</b>	0.3	
				<b>Width (m)</b>	1.6	
				<b>Length (m)</b>	30	
Contexts						
context no	type	Width (m)	Depth (m)	comment	finds	date
2701	Layer	-	0.3	Topsoil	-	-
2700	Layer	-	-	Natural	-	-



## APPENDIX B. FINDS REPORTS

### B.1 Pottery

*by John Cotter*

A single sherd of pottery weighing 7g. was recovered from context (901).

Context (901) Spot-date c 1400-1625

Description: Fairly small and very worn body sherd from a large wheel-thrown vessel of indeterminate form - possibly a large jug or jar? This is in an orange-pink sandy fabric typical of the late medieval phase of the Brill/Boarstall ware industry (Bucks). The external surfaces bears a small splash or greenish-brown glaze and possibly traces of incised line decoration.

### B.2 Ceramic building material (CBM)

*by John Cotter*

A single piece of CBM weighing 3g. was recovered.

Context (901) Spot-date: Post-medieval?

Description: A very small flattish scrap of pale orange-buff, fine sandy, fired clay - possibly from a post-medieval floor tile or brick?

### B.3 Stone and slate

*by John Cotter*

Two small pieces of stone and slate were recovered from two separate contexts.

Context (901) Spot-date: Modern?

Description: A small angular chipping (4g.) in a very hard dark grey stone - possibly Carboniferous limestone? This may be a piece of road chipping and thus probably modern.

Context (704) Spot-date: Late 18th to 20th century

Description: A small thin flake of modern grey slate (3g.). Probably Welsh roofing slate.

### B.4 Slag

*by John Cotter*

A single piece of slag was recovered.

Context (901) Spot-date: Post-medieval or modern?

Description: A small amorphous lump of dark grey slag (9g.). Brownish rusty patches in places. Dense and stony with thin vitreous light grey lenses. Possibly ironworking slag?



## **B.5 Glass**

*by John Cotter*

A single piece of glass was recovered.

Context (901) Spot-date: Modern

Description: A small shard of clear flat glass (1g.). The metal is clear, so is clearly of modern date. It is quite thin (c 1mm. thick) and so probably not window glass - although it may come from something like an electric torch window or a flat bottle? The surfaces are very scratched/abraded.

## **B.6 Iron objects**

*by John Cotter*

Five pieces of iron were recovered from two separate contexts.

Context (704) Spot-date: Modern?

Description: Three pieces (146g.). Folded/flattened rectangular strip of rusty iron sheeting (52mm. wide) with five nail or rivet holes at each end. An iron nail or piece of wire protrudes from one end. Probably some sort of cladding or casing? Also a separate modern-looking nail (95mm. long) and a separate slightly twisted length of thick rusty iron wire (32mm. long). These may come from a machine or engine of some sort.

Context (901) Spot-date: Modern?

Description: Two small pieces of rusty iron sheeting (4g.). Similar to that in context (704).



## APPENDIX C. ENVIRONMENTAL REPORTS

### C.1 Environmental samples

C.1.1 No environmental samples were taken.



## APPENDIX D. BIBLIOGRAPHY AND REFERENCES

English Heritage, 1991 *Management of Archaeological Projects*.

HeritageCollective LLP, 2012 Archaeological Desk Based Assessment, unpublished client report prepared on behalf of Summix Ltd

Hey, G, and Lacey, M, 2001 *Evaluation of Archaeological Decision-making Processes and Sampling Strategies*.

Morris, 1976 *Domesday Book: Berkshire*

Oxford Archaeology, 2000 OA Environmental Sampling Guidelines and Instruction, Manual.

Wilkinson, D (ed.), 1992, Fieldwork Manual, (first edition)



## APPENDIX E. SUMMARY OF SITE DETAILS

**Site name:** Cowans Camp Watchfield

**Site code:** WACAW 12

**Grid reference:** SU 24178 90390

**Type:** Evaluation

**Date and duration:** 3<sup>rd</sup> to 14<sup>th</sup> December 2012

**Area of site:** 6.4 ha.

**Summary of results:** Between the 3<sup>rd</sup> and the 14<sup>th</sup> of December 2012 Oxford Archaeology carried out an archaeological evaluation at Cowans Camp, Watchfield, Oxfordshire. Twenty-four trenches were located within the proposed development area. Excavation of the trenches revealed various features dating to the 20th Century use of the camp, including service trenches, two ditches and one pit. The evaluation also confirmed the location of a 19th century quarry marked on historic maps

**Location of archive:** The archive is currently held at Oxford Archaeology, Janus House, Osney Mead, Oxford, OX2 0ES, and will be deposited with the Oxfordshire County Museums Service in due course, under accession number: OXCMS 2012.153.





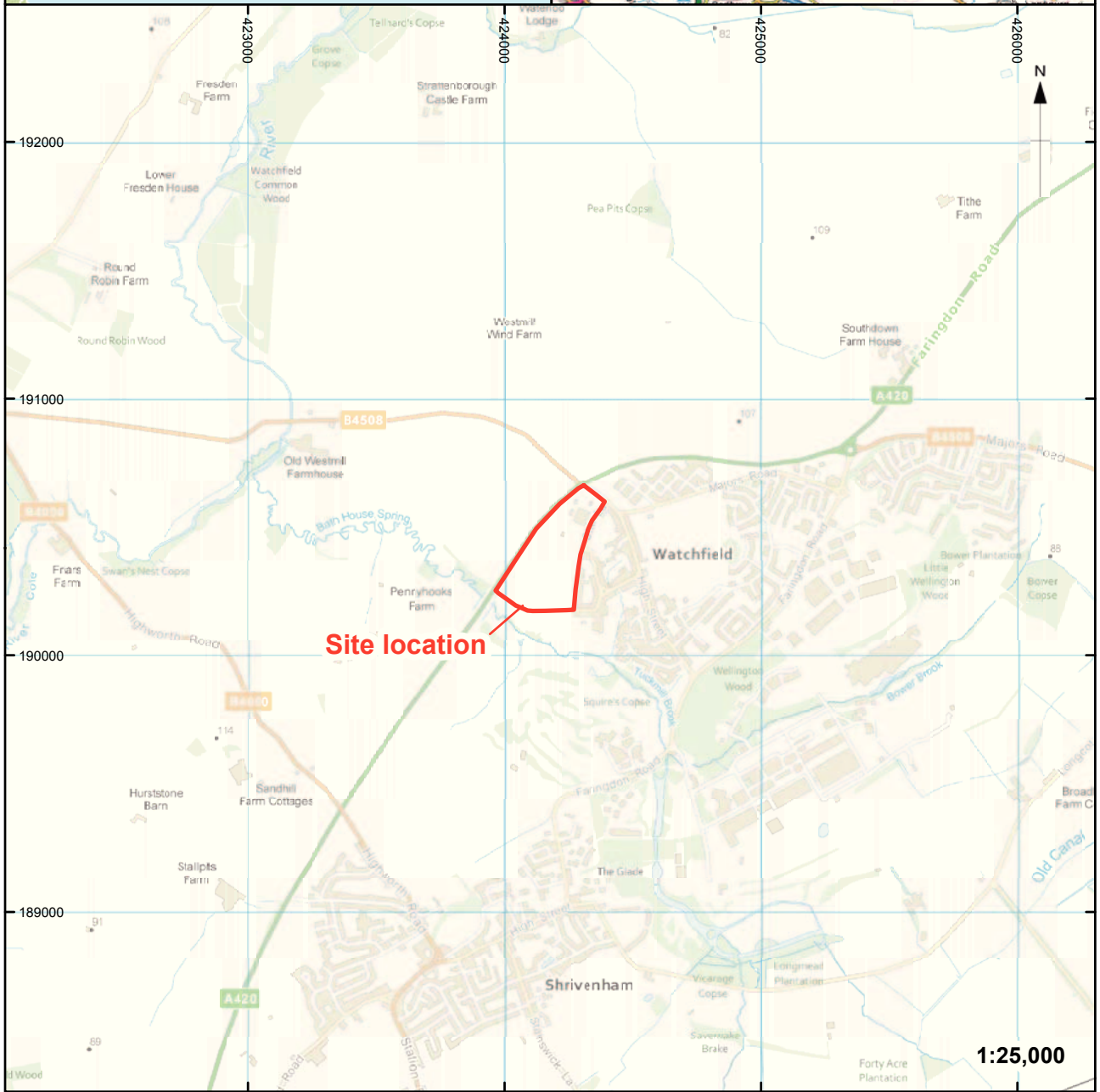

M:\TEMPLATES\GIS\ArcGIS 10\ArcGIS10\_Figure1\_Slim.mxd\hannah.kennedy\*19/10/2012

Contains Ordnance Survey data © Crown copyright and database right 2012

Figure 1: Site location



Figure 2: Plan of site and trench locations overlaid on Google satellite map

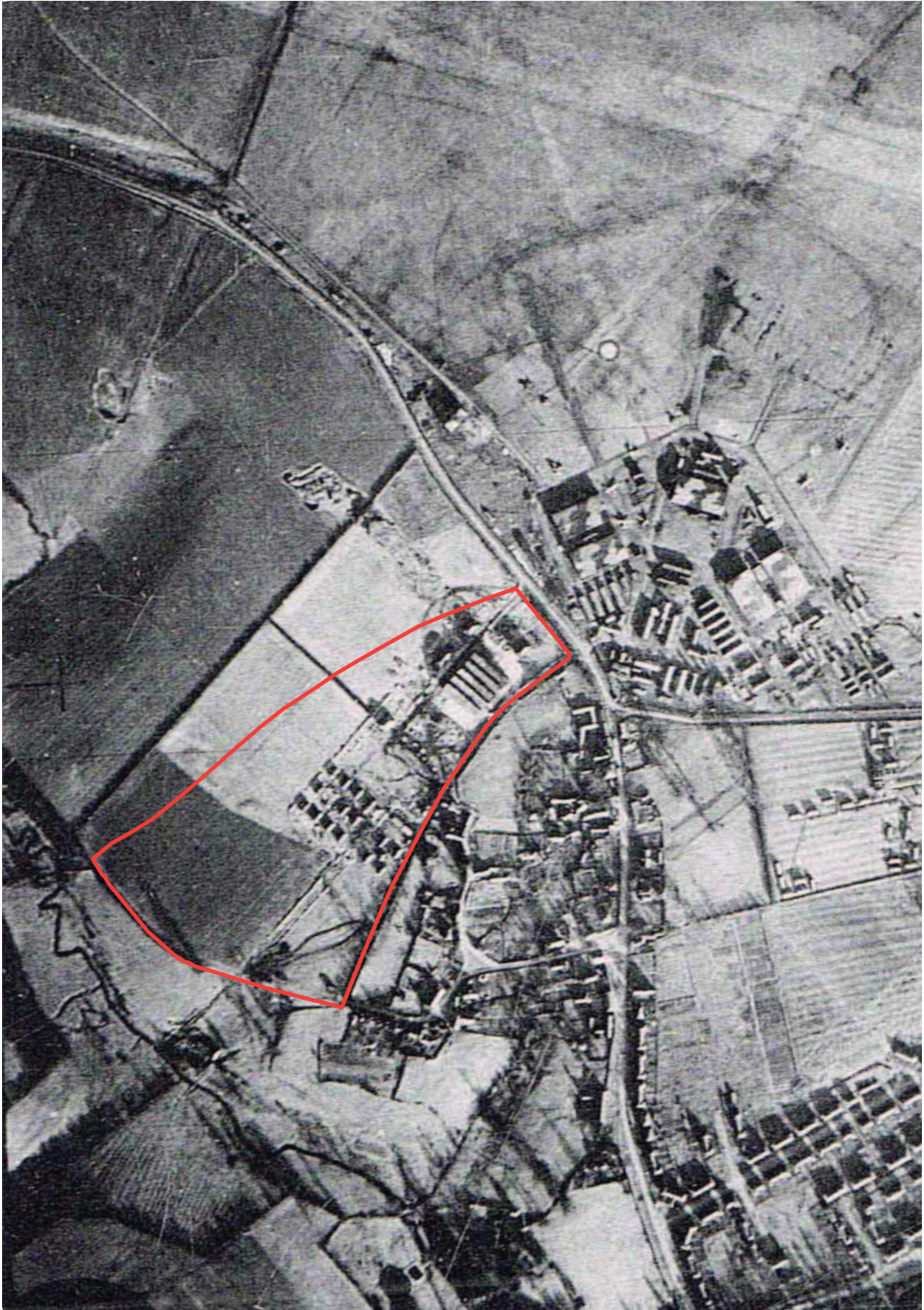

Figure 3: Aerial photograph of the site taken in 1942

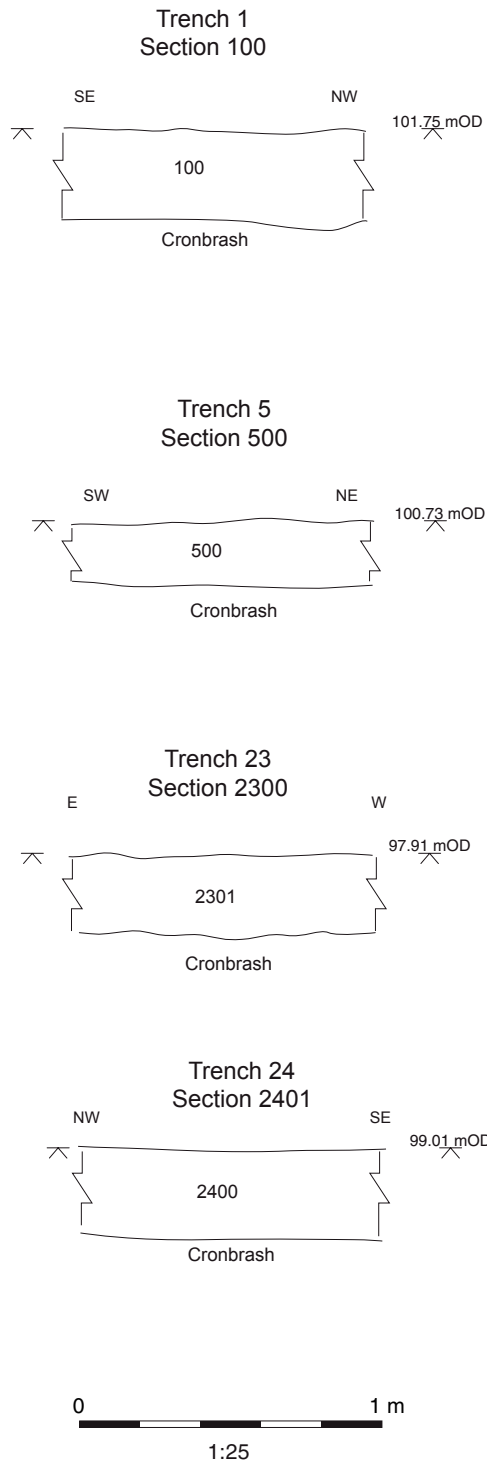

Figure 4: Representative sections from trenches 1, 5, 23 and 24

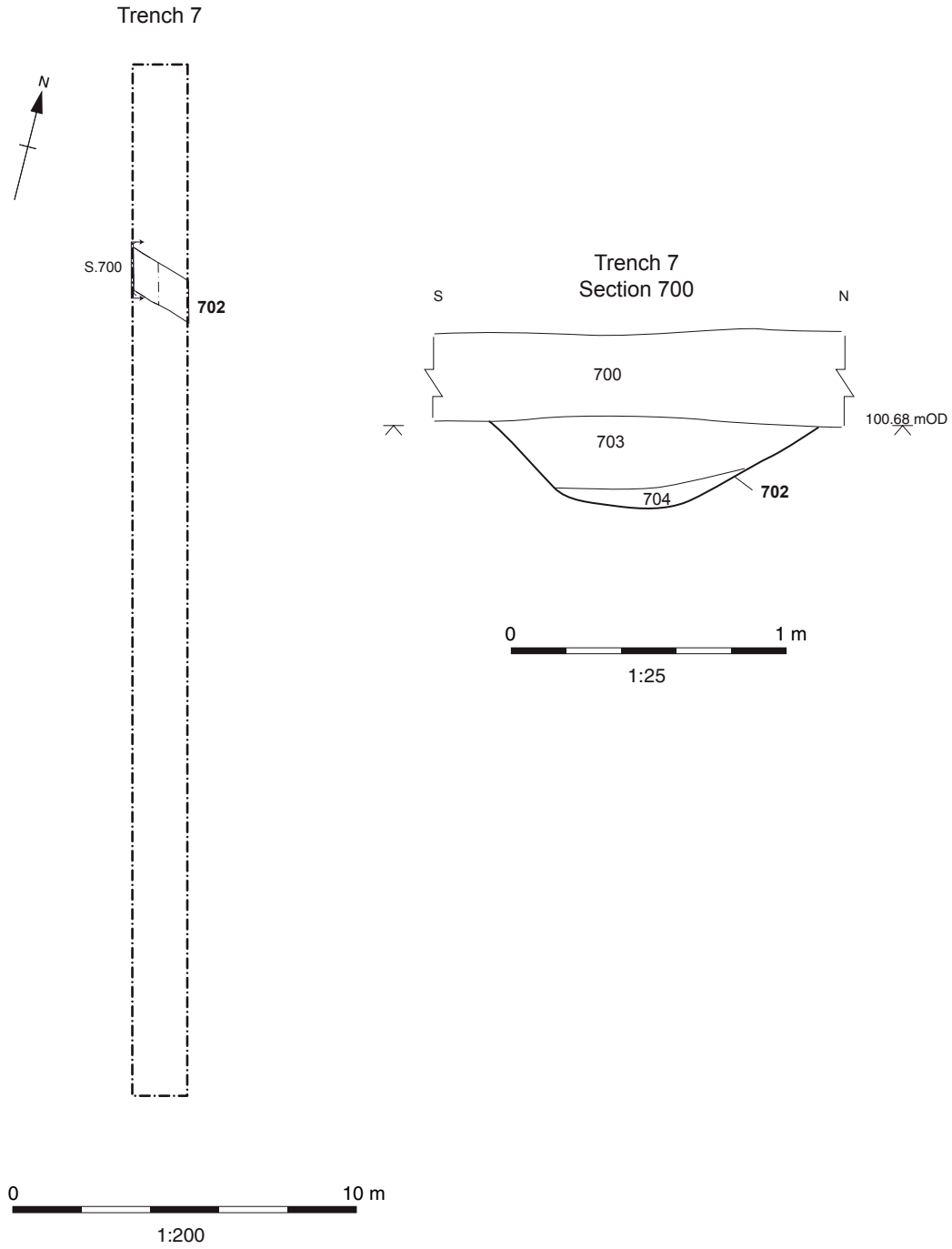

Figure 5: Plan of trench 7 and section of feature 702

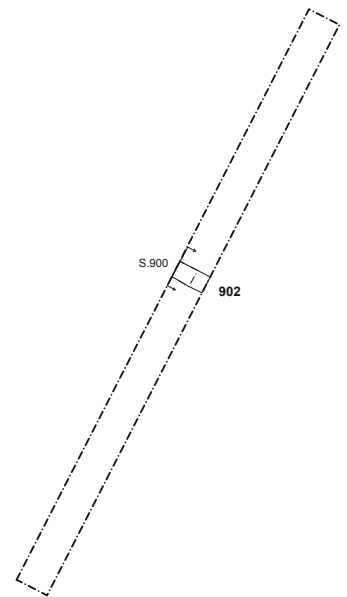
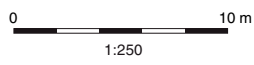
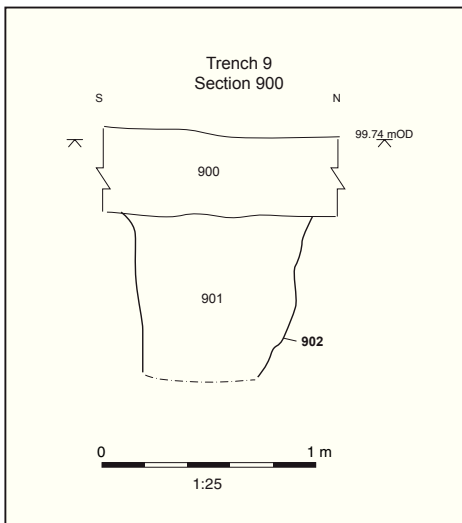
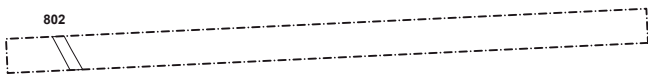

Figure 6: Plan of trenches 8 and 9 and section of feature 902

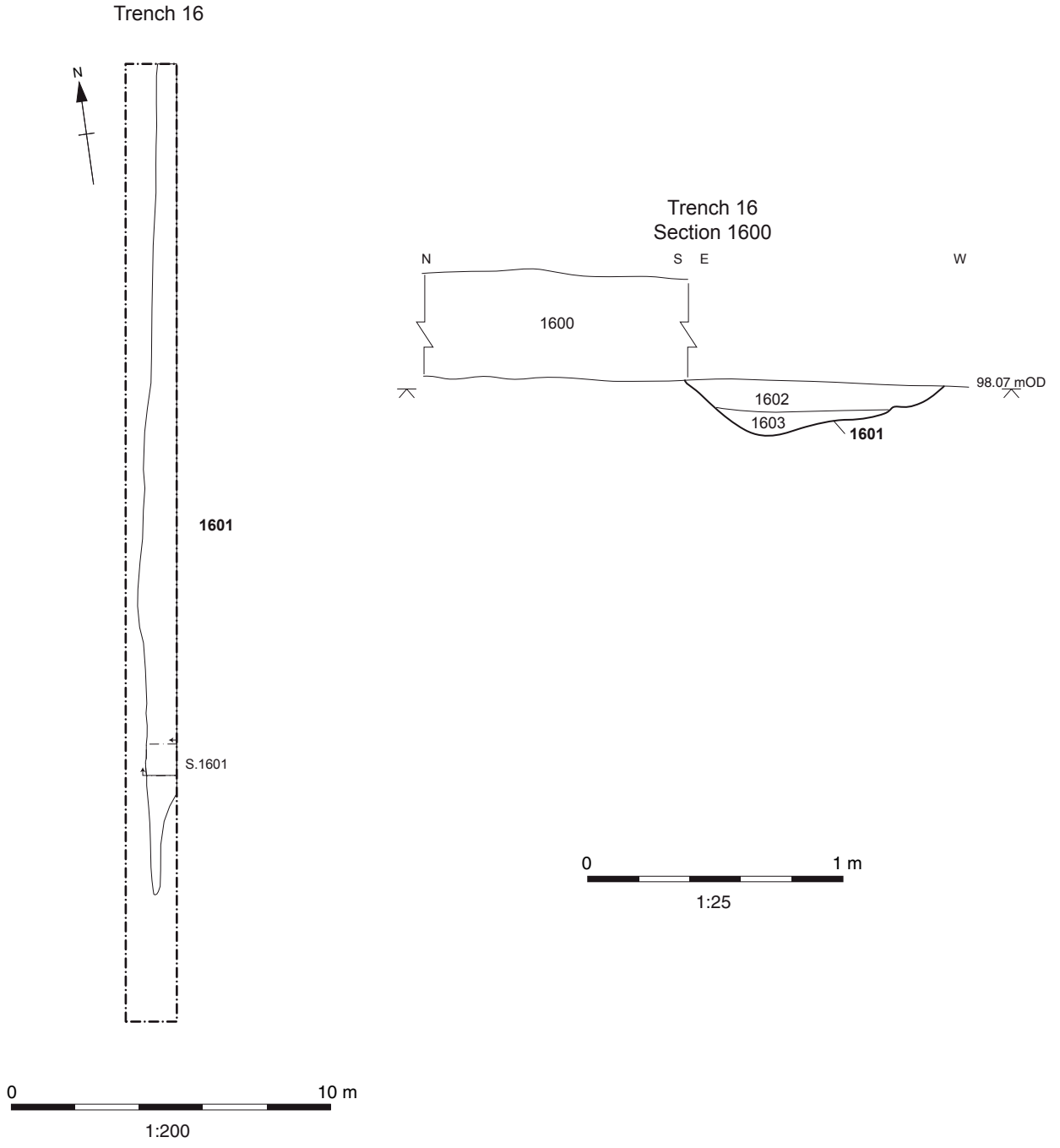

Figure 7: Plan of trench 16 and section of feature 1601

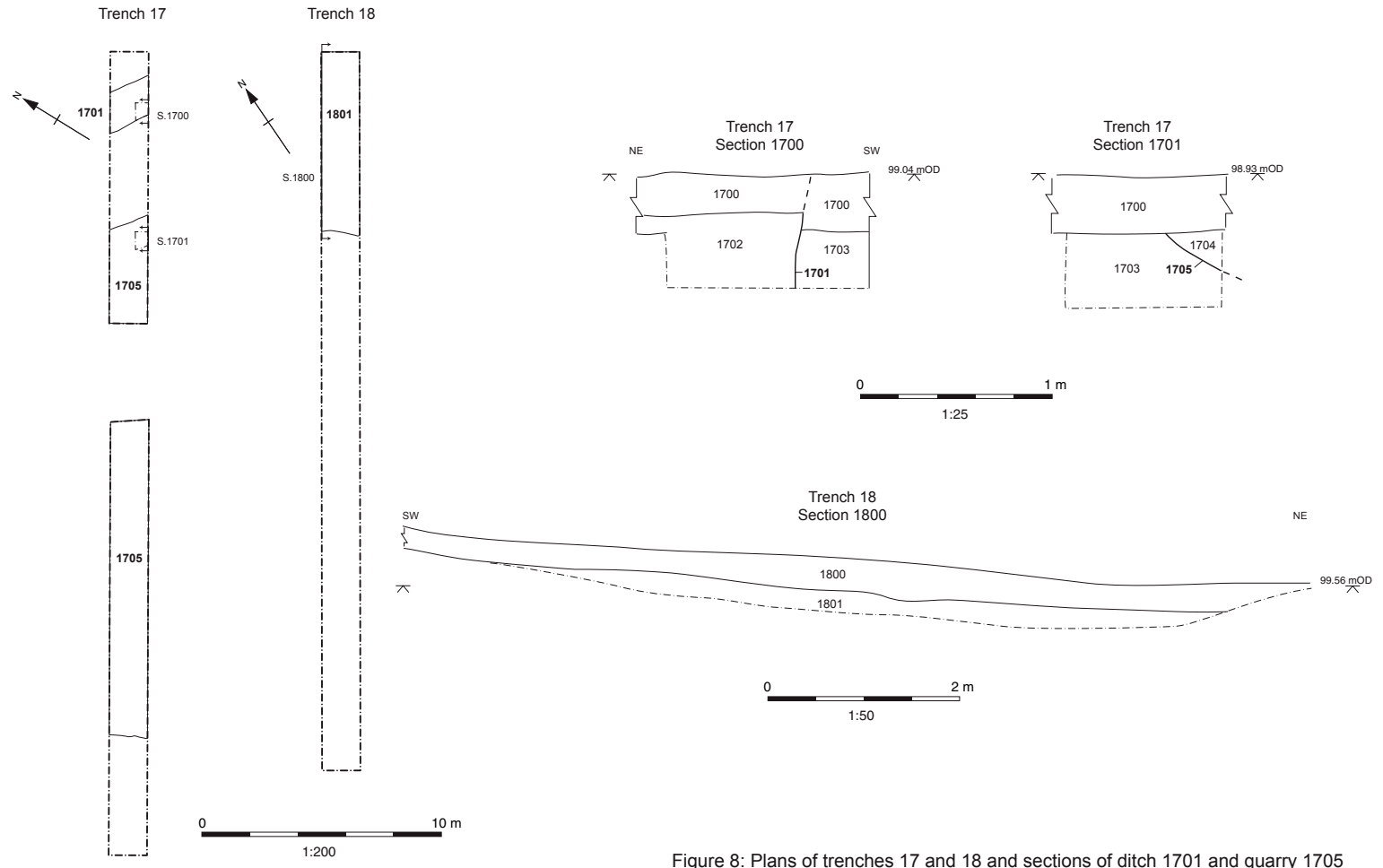

Figure 8: Plans of trenches 17 and 18 and sections of ditch 1701 and quarry 1705



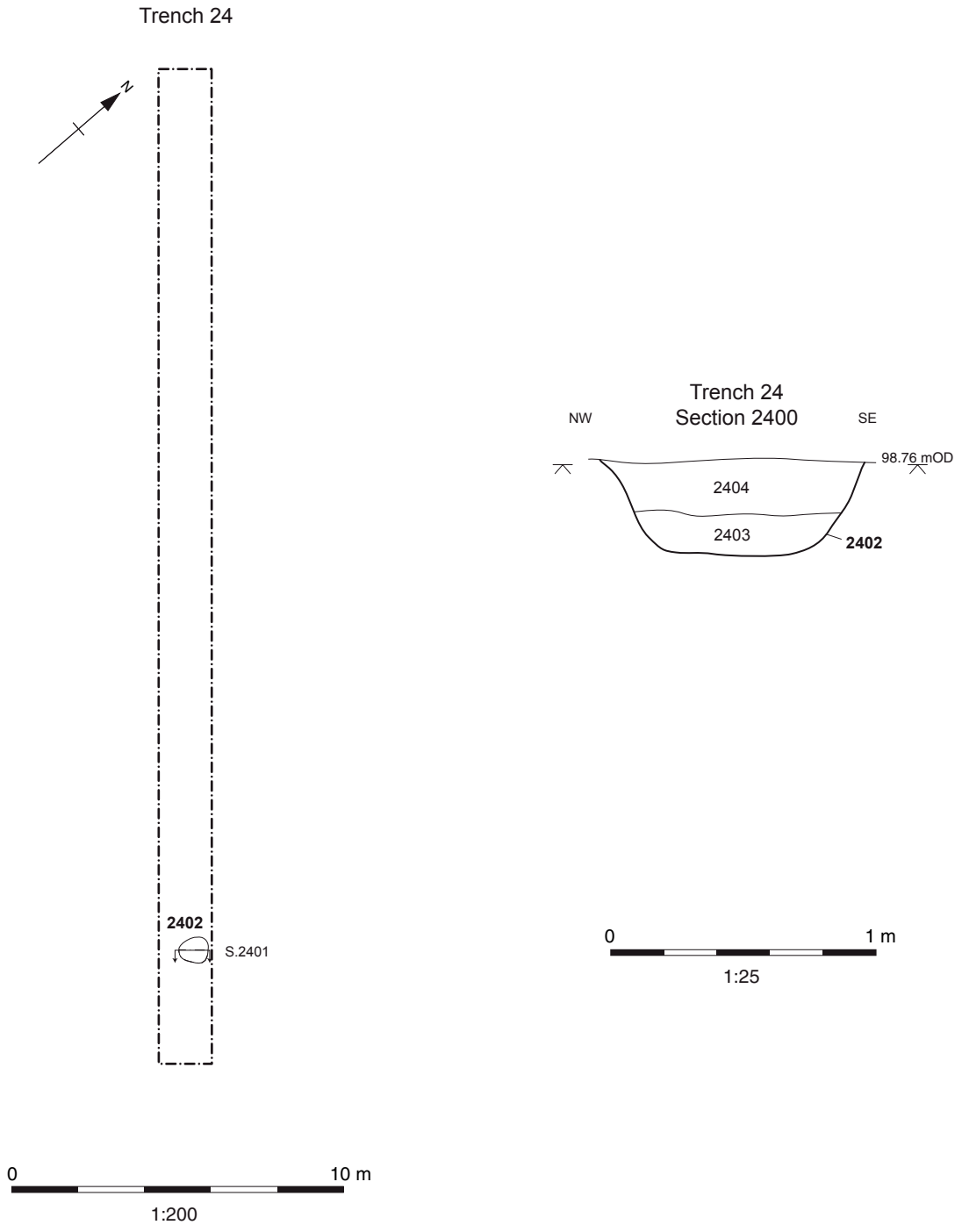

Figure 9: Plan of trench 24 and section of feature 2402



Plate 2: Ditch 702, Trench 7

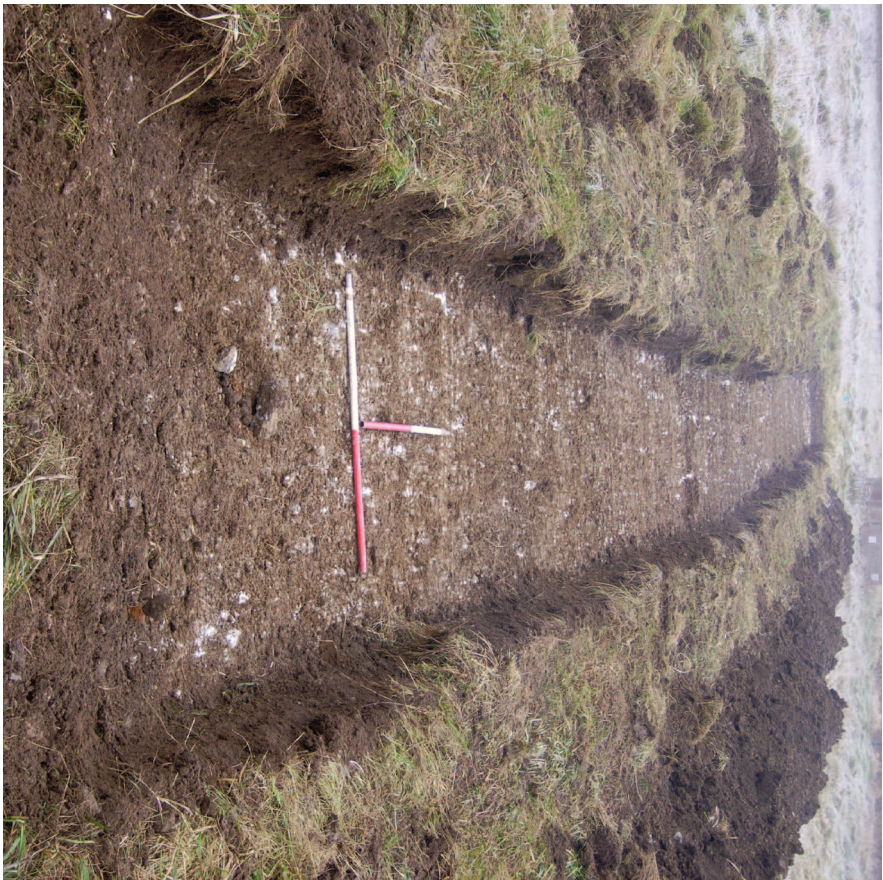

Plate 1: Trench 1



Plate 3: Modern service trench 902, Trench 9



Plate 4: Ditch 1601, Trench 16



Plate 5: Quarry 1705, Trench 17



Plate 6: Trench 23



Plate 7: Pit 2402, Trench 24



Plate 8: American Air Force graffiti on substation building





**Head Office/Registered Office/  
OA South**

Janus House  
Osney Mead  
Oxford OX2 0ES

t: +44 (0) 1865 263 800  
f: +44 (0) 1865 793 496  
e: info@oxfordarch.co.uk  
w: <http://thehumanjourney.net>

**OA North**

Mill 3  
Moor Lane  
Lancaster LA1 1GF

t: +44 (0) 1524 541 000  
f: +44 (0) 1524 848 606  
e: oanorth@thehumanjourney.net  
w: <http://thehumanjourney.net>

**OA East**

15 Trafalgar Way  
Bar Hill  
Cambridgeshire  
CB23 8SQ

t: +44 (0) 1223 850 500  
f: +44 (0) 1223 850 599  
e: oaeast@thehumanjourney.net  
w: <http://thehumanjourney.net>



**Director:** David Jennings, BA MIFA FSA

*Oxford Archaeology Ltd is a  
Private Limited Company, N<sup>o</sup>: 1618597  
and a Registered Charity, N<sup>o</sup>: 285627*