

Newbury Parkway Phase 1 Evaluation



Archaeological Evaluation Report



Oxford Archaeology

October 2005

Client: Shearer Property Group

Issue N^o: 1

OA Job N^o: 2851

NGR: SU 471 673

Client Name: Shearer Property Group
Client Ref No: N/A
Document Title: Newbury Parkway Phase 1 Evaluation

Document Type: Evaluation

Issue Number: 1

National Grid Reference: SU471673
Planning Reference: N/A

OA Job Number: TN2851
Site Code: NEWPP105
Invoice Code: NEWPP1EV
Receiving Museum: West Berkshire Heritage Services
Museum Accession No: TBC

Prepared by: R.Brown
Position: Senior Project Manager
Date: 11th October 2005

Checked by: R.Brown
Position: Senior Project Manager
Date: 11th October 2005

Approved by: Jon Hiller
Position: Senior Project Manager
Date: 12th October 2005

Signed.....

Document File Location: Server 1 NEWPP1EV
Graphics File Location: go i-pNEWPP1EV
Illustrated by: Julia Moxham

Disclaimer:

This document has been prepared for the titled project or named part thereof and should not be relied upon or used for any other project without an independent check being carried out as to its suitability and prior written authority of Oxford Archaeology being obtained. Oxford Archaeology accepts no responsibility or liability for the consequences of this document being used for a purpose other than the purposes for which it was commissioned. Any person/party using or relying on the document for such other purposes agrees, and will by such use or reliance be taken to confirm their agreement to indemnify Oxford Archaeology for all loss or damage resulting therefrom. Oxford Archaeology accepts no responsibility or liability for this document to any party other than the person/party by whom it was commissioned.

Oxford Archaeology
© Oxford Archaeological Unit Ltd 2005

Janus House
Osney Mead
Oxford OX2 0ES

t: (0044) 01865 263800
f: (0044) 01865 793496

e: info@oxfordarch.co.uk
w: www.oxfordarch.co.uk

Oxford Archaeological Unit Limited is a Registered Charity No: 285627

Shearer Property Group

Newbury Parkway

NGR SU 471 673

ARCHAEOLOGICAL EVALUATION REPORT - PHASE 1**CONTENTS**

1	Introduction	4
2	Site Location.....	4
3	Archaeological and Historical Background.....	4
4	Aims of the Investigation	12
5	Evaluation Methodology	12
6	Results: Descriptions	15
7	Discussion and Interpretation	26
8	Impact of the Development	29
	Appendix 1 Archaeological Context Inventory.....	30
	Appendix 2 Bibliography	39
	Appendix 3 Summary of Site Details.....	40
	Appendix 4 Pottery.....	41
	Appendix 5 Ceramic Building Material	46
	Appendix 6 Animal Bone.....	54

LIST OF FIGURES

- Fig.1 Site location
- Fig.2 Trench Location plan
- Fig.3 Trench 1 plan and section
- Fig.4 Trenches 2, 3, 4 schematic sections
- Fig.5 Trench 5 plan and section, Trench 6 section
- Fig.6 Trench 7 & 8 plans and sections
- Fig.7 Trench 9 section, Trench 10 plan and section

Summary

In August and September 2005 Oxford Archaeology carried out a field evaluation at Newbury Parkway (NGR SU 471 673), Newbury, Berkshire on behalf of Shearer Property Group.

The evaluation revealed an intact sequence of alluvial sediments comprising clays and peats overlying the gravel terrace of the River Kennet. No archaeological remains were found associated with these deposits. However the evaluation sample size was low in relation to the overall investigation area. Preservation of environmental indicators within this sequence was generally good.

The alluvial sequence was cut into by evidence of land demarcation (a maintained/re-cut burghage plot ditch) to the south-west of the site. Pottery retrieved from these features indicated a date after the late 12th century.

Much of the investigation area appeared to have been subject to formal reclamation (from marshland) in the late 12th century. This was evidenced by a distinct compacted layer that appeared in many of the trenches capping the peat which formed the upper part of the alluvial sequence. Yard surfaces found immediately to the rear of Northbrook Street are also likely to date from this period, as was a pit to the eastern side of the site.

Subsequent to the reclamation deposit, a gradual accumulation of deposits through dumping and silting was recorded in many of the trenches. A probable tanning waste pit dated to the 15th century was recorded to the central eastern part of the site.

Importation of garden soil in the middle 16th century was noted across the site, as well as pits related to construction during this period

A brick structure which most likely relates to 19th century culverting of a stream which formed the eastern boundary of the site was recorded.

1 INTRODUCTION

- 1.1 During the period 15/08/05 to the 08/09/05 Oxford Archaeology (OA) carried out a field evaluation at Newbury Parkway, Newbury (Fig.1) on behalf of Shearer Property Group. The work was carried out in respect of a proposed redevelopment of the site. The proposal area lies within an area of archaeological interest. Duncan Coe, Archaeological Officer for West Berkshire, therefore advised that some intrusive investigation should be carried out prior to a planning application in order to provide additional information to the environmental impact assessment that forms part of the application.
- 1.2 The programme of work was carried out in accordance with a Project Design produced by OA (OA 2005C) and agreed with Duncan Coe.

2 SITE LOCATION

- 2.1 The development site lies *c* 130 m to the north of the River Kennet and is bounded by Northbrook Street to the west, Parkway to the east, and Park Street to the north and is centred on SU 471673. The area is currently occupied by late post-medieval and modern buildings, car parking and the rear yards of 6-47 Northbrook Street. The proposed development footprint shows that the development will affect blocks of post-medieval buildings which front onto Northbrook Street and which are currently occupied by shops: several are listed as Grade II. Within the rear yards are a number of buildings, some post-medieval and others modern.
- 2.2 The site lies within the medieval core of Newbury and consequently has the potential to contain archaeological remains associated with the origins and development of the town. It also has the potential to reveal information concerning Newbury's role in the cloth industry, known to have taken place in the vicinity
- 2.3 The geology map shows the underlying geology as alluvium, which from previous investigations lies about 1m below ground level and has an average thickness of 1m. The waterlogged nature of the ground near the river to the south has produced layers of peat in many areas. The peat lies between *c* 1-2.3m below the ground surface and is up to 2.25 m thick. Peat has also been found away from the river in below-ground investigations in the vicinity of the development site leading to the assumption that peat as well as silt alluvium may also underlie this area. Below the alluvium are river gravels overlying the Reading Beds and Chalk.

3 ARCHAEOLOGICAL AND HISTORICAL BACKGROUND

- 3.1 Oxford Archaeology carried out a Desk-Based Assessment (DBA) of the general site area in 2000. This related to earlier development proposals which have been subsequently revised for this proposal. However the DBA includes coverage of a 300 m radius from the centre of the currently proposed development. The archaeological

and historical text below is extracted from that document. References have not been included and the DBA should be read in conjunction with this document. A more recent Desk-Top Assessment has been carried out by Bristol and Region Archaeological Services (BARAS 2003) on behalf of Elise Developments, this has also been reviewed.

- 3.2 A number of major archaeological excavations have taken place within the Study Area since 1970. Prior to this, knowledge about Newbury's past had come from chance discoveries made during building work. During the 19th century, prehistoric pile structures were discovered in Market Place, Cheap Street and Northbrook Street. Attempts were made to elucidate the stratigraphy of the latter. Roman material found in Market Place led to the suggestion of a mill by the river. Several Mesolithic flint working sites were found during 1930s, one during construction of the boating pool.
- 3.3 The first large scale archaeological investigation within Newbury was carried out by Newbury Museum Group in 1971-4 around Market Place. As well as Mesolithic flint, evidence for medieval and early post-medieval occupation was found. Further work by the Berkshire Archaeological Unit and Wessex Archaeology between 1979 and 1989 in the same area also found material from these periods as well as some early medieval pottery and ploughmarks (Vince *et al.* 1997).
- 3.4 Over the next ten years Wessex Archaeology carried out investigations a little further east at The Wharf. These yielded much information about the post-medieval canal basin, but failed to find any trace of the medieval castle, mentioned in a document of 1152.
- 3.5 In 1996 Thames Valley Archaeological Services excavated an area north of the development site on the opposite side of Parkway, by the cinema. Evidence was recovered for medieval peat cutting and there were also signs of habitation from the same period. The peat layer was about 0.9 m below the surface and about 0.4 m thick.
- 3.6 Alongside the area of proposed development, north of the River Kennet and behind Northbrook Street, Thames Valley Archaeological Services carried out excavations in advance of construction of the Camp Hopson Furniture Store. Peat was found in 3 of the 6 trenches and was also found in 2 boreholes dug on the site, at depths of 1-2 m below ground. The peat layer was found in a band running north east to south west and varied from 0.2 m to 2.25 m in thickness. Environmental evidence gave an Early Mesolithic date to what was interpreted as a palaeochannel. Large deposits of bone and a quantity of leather offcuts, probably from butchery and a tannery, were found in post-medieval rubbish tips, retained by wooden hurdles. The remains of the 19th-century ornamental lake in the grounds of Marsh House was also detected.

3.6.1 Prehistoric

3.6.2 Mesolithic

Development area

- 3.6.3 The area of proposed development contains no known material from the Mesolithic period. However, immediately adjacent to the development area itself at the rear of 6-12 Northbrook Street, a palaeochannel was discovered and peat samples from it produced evidence for Mesolithic woodland (OAU DBA - 2). It is possible that this channel continues into the south east corner of the site (Hull 1997).

Study area

- 3.6.4 Mesolithic deposits have been recovered from many sites along the River Kennet, most significantly from Thatcham, c 2km east. Within Newbury itself flints are common. Three flint working sites have been excavated there (OAU DBA 13,14,15) and six blades were recovered from a garden just north of the park (OAU DBA 25). On the other side of the river worked flint was found in river gravel in Bartholomew Street (OAU DBA 3) and on the corner of Cheap Street and Market Place. A flint working site was discovered at 1-3 Market Place (OAU DBA 4).
- 3.6.5 The Kennet Valley is rich in prehistoric archaeology and material from other periods, some of which have been found in Newbury. Palaeolithic flints were recovered from clay just above the river gravel (OAU DBA 21) during excavations in Northbrook Street at the turn of the century. Several examples of wooden pile structures have been found in peat layers close to the river, but as these discoveries were made in the 19th Century none have been accurately dated. Money (1905) assigned a Neolithic date to a platform of fir poles supported by piles 2 m long (OAU DBA 1), but other authorities suggest it was Iron Age in date. Another structure in Northbrook Street (OAU DBA 16) was also given an Iron Age date.

3.6.6 Later Prehistoric

Development area

- 3.6.7 The area of proposed development contains no known material from the later prehistoric period.

Study area

- 3.6.8 There is less evidence for Neolithic activity in Newbury. Within the study area, apart from the possible pile structure already discussed, there are only a quern fragment (OAU DBA1) in the Market Place and an axe (OAU DBA 22) to the west of the study area. A single Bronze Age find has been recovered, a spearhead (OAU DBA13) from Victoria Park. Elsewhere in the Kennet Valley towards Reading, east of Newbury, there is much more evidence for Bronze Age activity.

3.6.9 A few Iron Age artefacts have been found, including a bridle fitting made from antler (OAU DBA 22) and a bone awl (OAU DBA1). Other bone tools came from the Market Place, but with no dating evidence.

3.6.10 Roman

Development area

3.6.11 The area of proposed development contains no known material from the Roman period.

Study area

3.6.12 Roman material has been found at many locations in the southern part of the Study Area (OAU DBA 1,11,20). This evidence includes coins, pottery, tile, and two bronze steelyards from scales, which, it has been suggested, may have been in use in a mill. A lamp (OAU DBA16) was found in Northbrook Street and Money (1905) claims that horseshoes, tile, bronze implements and sandal fragments occurred in the lower levels of the old road surfaces. A cemetery was found in 1865 at the railway sidings, about 1 km south east of the development area, and further finds including a building with a hypocaust were found a further 1.5 km away. This suggests that a settlement existed in the vicinity of the town (Astill 1978). Money (1905) argued for a Roman road running along Northbrook Street. Shaw and Ford (1976) suggested that ditches found in Bartholomew Street could have run either side of a Roman road.

3.6.13 Early Medieval

3.6.14 Newbury was not a focus for settlement during the Anglo-Saxon period, its first documentary reference coming around 1080. The area is thought to have lain in the lost manor of Ulvritone. Some pottery has been found in Market Place (OAU DBA 1) and plough marks and ditches below medieval building layers in Bartholomew Street are believed to be Anglo-Saxon.

3.6.15 Medieval

Development area

3.6.16 The development area lies within the medieval core of Newbury. Although no medieval maps have been found, Astill (1978) has attempted to plot all the medieval features of the town. On the east side of Northbrook Street where the development area is situated, the land has the typically medieval lay-out of long, narrow burgage plots. Houses would have been erected along the front with an area of garden or industrial activity behind. Typically these back yards would contain wells, yard surfaces and evidence of small-scale industries. Normally a back lane would have run along the rear of the properties, but here it is appears that a stream ran down towards the river forming the rear boundary. To the east of this stream an area of marshy ground is thought to have been situated (Astill 1978), now Victoria Park.

3.6.17 The location of the development site and the presence of the stream at the back would have made the medieval burgage plots on this site ideally placed for use as shops with small scale industries carried out to the rear of the property. The stream would have made it an ideal site for the manufacturing processes involved with the processing of cloth, known to have been carried out in this area. It is possible that these back yards would have been used for fulling, tanning and possibly even milling. The stream and any associated alluvium may preserve organic evidence of these activities. It appears from historic map evidence that this stream may only have been canalised in the 18th century, and its medieval course would have been much more meandering and its original exact course under the development site is not known. The burgage plots would have probably sloped down towards the stream at the back, with maybe some build up and levelling to prevent frequent flooding. The plots were therefore probably not totally drained and levelled until the post-medieval period.

Study area

3.6.18 Newbury may have been created shortly after the Norman conquest by Arnulf de Hesdin, lord of the lost manor of *Ulvritone*. The manor's value increased from £9 to £24 between 1066 and 1086 when 51 building plots were listed. Money's 1887 *History of Newbury* contains an attempt to plot the layout of this 'new market town' and show its relationship to the manor of *Ulvritone*. It shows no development north of the river apart from West Mills although the bridge and roads are in place. From an early date the 'Y-shape' formed by Bartholomew Street, Cheap Street and Northbrook Street formed the core of the town, but whether the last was established at the same time or slightly later is not known. To the north of the medieval town lies Speenhamland. This is now a suburb, but in 1225 when it was first mentioned, it formed part of the manor of Speen (OAU DBA 9).

3.6.19 There is abundant evidence for the medieval town from the Study Area, with floor levels and pottery found in Northbrook Street (OAU DBA 1), Bartholomew Street (OAU 3) and Market Place (OAU 4). Finds of pottery and coins (OAU DBA 1,4,7,16) are common, but a copper figurine (OAU DBA 11) has also been recovered. No medieval houses survive although when a Queen Anne house in Bartholomew Street (OAU DBA 3) was demolished a 15th Century hall house was found incorporated in it. It is likely that other existing buildings have a medieval core, particularly the stable block at 63 Northbrook Street (OAU DBA 5).

3.6.20 St Nicholas Church was first mentioned in 1080 and three chantries are recorded as founded in the church in 1330. The present building is post-medieval in date, but excavations in 1992 uncovered a section of medieval wall below the floor (OAU DBA 8). A chapel is said to have existed at the north end of Northbrook Street (OAU DBA 9), but the only evidence comes from the name given to cottages at that corner. No trace has been found of Newbury Castle (OAU DBA 2), mentioned in 1152 and thought to have stood in the area of the canal wharf. There are no further references to it and the date of demolition is unknown. Although excavations did not find the castle, it has been suggested (Vince *et al* 1997) that a pottery assemblage came from its midden (OAU DBA 4). By the end of the 12th century the Hospitallers had a

preceptory in Newbury (OAU DBA 6), said to be 'at the foregate of the castle'. A section of medieval wall, built in ashlar and thought to be part of the boundary wall of the preceptory (OAU DBA 7), was destroyed by construction of the relief road.

- 3.6.21 The medieval timber bridge is better documented although nothing remains. It had shops on it and collapsed in 1643 (OAU DBA 1). Corn, fulling and tanning mills are known to have existed and on all the post-medieval maps, mills are shown either side of the River Kennet. When Town Mills (OAU DBA 18) on the south bank was demolished, a medieval building was found inside which suggests that the medieval mills were on the same sites as the later ones.
- 3.6.22 Evidence for another medieval activity was found in 1996 in excavations north of the cinema site on the Parkway. Linear features in peat deposits suggested peat cutting (OAU DBA 19) and the lack of structures suggested the site was outside the built-up area of the medieval town.

3.6.23 Post-medieval

Development area

- 3.6.24 The earliest map examined which shows Newbury dates from *c* 1750 when William Watts prepared a map showing the road network between Newbury and Hungerford. Very little detail is shown - the only recognisable building is St Nicholas Church, but it is clear that the town concentrated along the 'Y-shape' of Northbrook Street, Bartholomew Street and Market Place. For the development area, only the presence of buildings along Northbrook Street is shown with the burgage plots not shown.
- 3.6.25 Rocque's 1761 Map of Berkshire shows the limits of the town which is essentially the area of the medieval town as recorded by Astill (1978). Within the development area some buildings have been erected to the rear of the houses within the burgage plots.
- 3.6.26 Wills produced a map in 1768 which was used for the frontispiece of Money's book in 1887. This is the first detailed map of the development area and it shows development still concentrating on the central 'Y-shape' with expansion taking place at the bottom of Bartholomew Street in the general direction of Hungerford. The map shows that the stream running along the eastern boundary of the development area as having been canalised into a straight line, this may indicate that the rear of the plots were drained at the same time, although only a few buildings appear to have been built on the backs of these plots at this time.
- 3.6.27 The scale of the Ordnance Survey Old Series, 1" to 1 mile of 1817 means that no detail can be determined, but there appears to have been some further building on the rear of the burgage plots within the development area.
- 3.6.28 The 1839 Tithe Map does not show significant differences in the area of the town, but has more accurate representations of building layout. The medieval burgage plots can still be clearly distinguished running back from all three main streets. The main change on the development site however, is the dramatic increase in the number of buildings built within the whole of the burgage plots. The area marked 517, within

the development area contains a brewhouse. This dramatic increase in the number of buildings within the plots may be due to the fact that the rear of the plots had now been drained and levelled. This would have involved the dumping of material, especially near the rear of the burgage plots to level off the slope which would have run downwards to the stream.

3.6.29 On the 1st Edition 25" OS map changes can be seen behind the Northbrook Street properties, particularly to the west. Several new terraces of houses have been constructed with building lines at right angles to the burgage plots over which some of them have been built. A rear access road, has been constructed, Marsh Road, which runs down the west edge of the Marsh, forming the eastern side of the development area. Within it the brewhouse is now marked as a brewery. After the cloth industry declined at the end of the 17th century, brewing and malting became very important for Newbury's prosperity.

3.6.30 *Study area*

3.6.31 Newbury grew in size during the 15th century as the wool and cloth industries expanded. It had its greatest importance in the late 16th and early 17th centuries, receiving a charter of incorporation in 1596. Many clothiers are documented as having houses and shops in Northbrook Street which is thought to have been the centre of the industry (Astill 1978). The cloth manufacturing process would have needed plenty of fresh water and this would have been supplied from the many small streams present in this area, for example the stream shown on the Tithe Map running down the western side of Northbrook Street is thought to have supplied the workshops (OAU DBA 5).

3.6.32 The decline of the cloth industry had a severe effect and the town's fortunes only revived after the expansion of transport systems in the 18th Century. It became an important coach stop on the Bath - London Road (OAU DBA 24) and after the Kennet and Avon Canal was opened in 1797 new industries such as brewing became established. Several bridges were constructed across the river, the last timber one of 1726 being replaced by a stone construction in 1769-72 which is still standing (OAU DBA 1).

3.6.33 The prosperity of the town is illustrated by the large number of Listed Buildings within the Study Area, some of which are directly linked to the cloth industry. At 24 Northbrook Street is an early 16th century building (OAU DBA 5), much altered but originally part of a courtyard complex, known as 'Jack of Newbury's house'. This II* building belonged to John Smallwood, a cloth merchant, who paid for the new St Nicholas Church (OAU DBA 8) built in 1509-33 and Listed Grade I. In Market Place another Grade I building, the Cloth Hall remains. Built in 1626-7 as a cloth factory, it became a grain store in 1714, was restored in the 19th century and has now been converted to a museum, together with the Grade II* Old Granary, which dates from the late 17th century (OAU DBA 4). A new Italianate Corn Exchange, Grade II, was built in 1861-2. In 1686 a Market Cross stood in the centre of Market Place, but Willis's map in 1768 was marked 'site of' (OAU DBA 3).

- 3.6.34 There is evidence that a variety of other industries operated within the town, some continuing into the 20th century. Town Mill (OAU DBA 18) was still working in 1962 although it and West Mill have both been demolished since. When the rear of 6-12 Northbrook Street was excavated in 1997 rubbish deposits suggested tanning and butchery had been carried out on the site (OAU DBA 2).
- 3.6.35 After the Kennet and Avon Canal opened in 1797 a major wharf and basin was established in the south east of the Study Area. The basins were filled in during 1931 and the wharf area now lies under car parking and the relief road. Excavations on the site found evidence for cranes, coal yards, warehousing and granaries (OAU DBA 17). It was also possible to detect where the River Kennet had been canalised and its course altered (OAU DBA 2). On the west side of the bridge the river and canal are separated by Lock Island (OAU DBA 8). To its south is Newbury Lock, Listed Grade II, which is the only example with geared lever operated paddles in southern England. The lock keeper's cottage, Listed Grade II, burnt down in 1989.
- 3.6.36 Pottery and other material from the post-medieval period are found throughout the town. However more unusual finds include a lead cloth seal from Victoria Park (OAU DBA 23) and a halberd near West Mills (OAU DBA 8).

3.6.37 Modern

Development area

- 3.6.38 Little change can be seen on the 2nd edition 1900 OS map, but the uses of particular buildings are marked more extensively. There is a malthouse adjoining the brewery and another in the south east of the area, reflecting the importance of these industries in the town. The buildings along Northbrook Street include a public house, a hotel and the Baptist chapel, none of which retained these functions to the present. Next to the development site, the non-conformist chapel by the river apparently had a burial ground.
- 3.6.39 The 1930s OS map, shows that the brewery has ceased to operate, although another public house has opened. The burial ground is also disused.
- 3.6.40 During the second half of the 20th century Newbury experienced considerable change. Many of the buildings on the rear plots within the development area were demolished, including the terraces of houses on Jack Street and Winchcombe Place. Northbrook Street is now predominantly commercial. Northbrook Street is lined with shops, many of which occupy blocks of 18th and 19th-century buildings. Behind, the former burgage plots are covered by small businesses and the service yards of the larger concerns. Along the east side of the site, Marsh Road had been replaced by the much wider Parkway, which has parking along both sides and along the centre.

Study Area

- 3.6.41 Late 20th century change in Newbury can be seen throughout the study area. New roads have been constructed in the east of the Study Area and the layout of burgage properties along the three main streets has been obscured by development. By 1978

Astill estimated that 25% of the properties fronting these streets had been redeveloped and he listed a further fourteen sites for which permission had already been granted. More development has occurred in the intervening period. Prior to 1971 such work had been accompanied by little archaeological recording.

3.6.42 The biggest changes surround Victoria Park. Marsh Road along its west side is now The Parkway, widened and extended over the river to end in the canal wharf area which has been completely filled in. The ring road runs along the east, also crossing the river to the former wharf. In the park itself recreational facilities have been constructed.

3.6.43 *Archaeological Works subsequent to 2000*

3.6.44 A rapid interrogation of the Newbury Historic Characterisation Survey shows that numerous interventions and surveys have been carried out in Newbury subsequent to the OA 2000 DBA (including historic buildings/roof recording at 24 Northbrook street and Watching Brief at the Camp Hopson Department Store). However none of these add significant additional information for the purpose of evaluating below ground archaeological deposits at this site.

4 AIMS OF THE INVESTIGATION

4.1 The general aims and objectives of the evaluation were as follows:

- To determine or confirm the general nature of any remains present.
- To determine or confirm the approximate date or date range of any remains, by means of other evidence.
- To determine or confirm the approximate extent of any remains.
- To determine the condition and state of preservation of any remains.
- To determine the degree of complexity of the horizontal and/or vertical stratigraphy present.
- To determine or confirm the likely range, quality and quantity of any artefactual evidence present.
- To determine the potential of the site to provide palaeo-environmental and/or economic evidence and the forms in which such evidence may be present.
- To make available the results of the investigation.

5 EVALUATION METHODOLOGY

5.1 Scope of fieldwork

5.1.1 The evaluation consisted of 10 trenches in total (Fig.2). Trench measurements are given in the table below.

Trench	Dimensions
1	7 m x 2 m
2	11 m x 2 m
3	4.2 m x 2 m
4	10 m x 2 m
5	9 m x 2 m
6	4.5 m x 2 m
7	15 m x 2 m
8	4 m x 2 m
9	4.7 m x 2 m
10	8 m x 2 m

5.2 Fieldwork methods and recording

5.2.1 Mechanical excavation was carried out with a JCB. All mechanical excavation was carried out in such a manner so as to avoid or minimise damage to the archaeological remains. All machinery used was of an appropriate nature and power to suit the situation and mechanical excavators were fitted with ditching buckets. The Project Officer in charge of fieldwork directly supervised all machine work.

5.2.2 All undifferentiated topsoil or overburden of recent origin was removed down to the first significant archaeological horizon.

5.2.3 Spoil was scanned for artefacts, which were recorded and retained. Excavations below 1.2 m were only accessed once shoring had been installed. The depth and complexity of the deposits across the site was characterised. Records were made of the stratigraphy of all trenches.

5.2.4 Full written and drawn records of all excavated contexts were made in accordance with best archaeological practice. Archaeological deposits, which were not excavated, were recorded to the maximum extent possible *in-situ*. Records include overall trench and site plans. A single context planning methodology was used as appropriate. All

excavation and recording was in accordance with the IFA *Standard and Guidance for Field Evaluations* (IFA 2001).

- 5.2.5 Fieldwork procedures unless stated otherwise above were as set out in Appendix 2 and 3 of the *OA Field Manual* (Wilkinson, D 1992).

5.3 **Finds**

- 5.3.1 Finds were recovered by hand during the course of the excavation and bagged by context. Finds of special interest were given a unique small find number.
- 5.3.2 Recording, cleaning and conservation of finds followed the IFA *Guidelines for collection, documentation research and conservation of archaeological materials* (IFA 2001).

5.4 **Palaeo-environmental evidence**

- 5.4.1 Thirty-five environmental samples were taken from the 10 evaluation trenches. These samples were taken to assess the preservation of ecofactual evidence relevant to environment and economic activity and to recover small bones and artefacts. The samples were collected predominantly from the underlying alluvial sediments excavated by machine. These trenches encountered an underlying sequence of peat, overlying gravel with an occasional alluvial clay interface.
- 5.4.2 Three samples from the peat were processed to assess the preservation of macroscopic plant remains. One litre of the samples was hand floated onto a 250 micron mesh, and any residue was retained. The samples were stored wet and sub-samples of c 100ml of the flots were scanned under a binocular microscope. One sample was taken from a medieval dumped deposit to assess the preservation of charred plant remains and recover small bones and artefacts. Ten samples from the gravel deposits were wet sieved for lithic retrieval. The alluvial deposits and the charred medieval deposit were processed by floatation using a modified Siraf-type machine, the flot being collected onto a 250 micron mesh. The residues were passed through a column of sieves with apertures of 10 mm, 4 mm, 2 mm and 0.5 mm. The alluvial flots were kept wet due to significant quantities of organic non-carbonised material in the flots, the medieval flot was dried. All the residue fractions were retained and air-dried, the fractions were then sorted for artefacts and small bones up to 4 mm. Sub-samples of c 250ml were taken from all the samples prior to processing and retained for possible pollen/diatom/ostracod assessment at a later date. The remaining samples have been retained for incorporation into further work.

5.5 **Presentation of results**

- 5.5.1 In the following sections the deposits are described by trench. There is additional comment on the finds and the reliability of the results. The stratigraphy of each trench is described individually, in summary form followed by a detailed description. A

discussion, interpretation and conclusions of the evaluation then follows. A context inventory, including finds lists, is included in Appendix 1.

6 RESULTS: DESCRIPTIONS

6.1 Trench 1

(See Fig. 3)

6.1.1 Trench 1 was positioned in the central western part of the Marks and Spencers car park. It measured 7 m by 2 m and was orientated north-south. Existing ground level was *c* 75.85 m OD. The trench was initially excavated to a depth of 1.2 m. After recording the trench was then further machine excavated to *c* 2 m depth. Archaeological features were revealed at this depth. Shoring was installed and the features excavated. Subsequently a machine dug test pit was excavated to the depth of river gravels.

Stratigraphic description

6.1.2 River gravels (158) were encountered at 72.8 m OD. These were bulk sampled for evidence of lithics. None were retrieved. The river gravels were overlain by a 1.3 m sequence of peat (157 = 144 and 152). Root and (natural) wood fragments as well as fragmented insect remains were retrieved from flotation of samples from this sequence.

6.1.3 An east-west orientated depression in the upper surface of the peat sequence to the north of the trench (presumably erosion caused by water drainage, and likely to have formed the boundary between former burghage plots) was filled primarily with a gravel deposit (129). Pottery characteristic of a late 12th century date was retrieved from this deposit (this was retrieved from samples and spot dated. It is not included in the full pottery report). A thin sequence of silts and clays (130, 151 and 131) overlay deposit 129 within the depression.

6.1.4 To the south and central part of the trench (also at the northern-most limit) a compact clay and gravel deposit (146=138) overlay peat layer 152. This has been interpreted as an event representing purposeful reclamation of marshland, due to the distinct interface between the upper peat and this layer as well as the evidence from other trenches which also show a clear change from natural soil formation processes to compacted imported/dumped material. Sheep/goat and cattle bone was retrieved from this layer.

6.1.5 Deposit 146 was cut in the northern half of the trench by an east west aligned linear feature (150). This was filled with a sequence of silts (126=145,127=147, 148, 137, 132,136,126 and 153). Pottery giving an indicative 13th century date was recovered from this sequence.

6.1.6 The fills (126/153) of cut 150 were overlain by a series of clay-silts (139,140,127 and 128) that sloped down from the north, giving the impression of a bank encroaching on the silt-filled feature. Cattle bone was retrieved from this sequence.

- 6.1.7 The sequence was cut by a feature (141) which was interpreted on-site as a pit. However it was noted that the feature was not clear in plan, and in hindsight it may sensibly be interpreted as a linear feature representing re-cutting/re-establishment of the boundary along the line of cut 150. Pottery recovered from this feature is dated from the late 12th -14th century. In relation to stratigraphic relationships a 13th-14th date is likely for this feature.
- 6.1.8 A thick series of mixed deposits (101,104 and 102) sealed the fill of feature 141 and overlay deposit 146. This appears to be more than one event of large-scale dumping. Deposit 101, which is to the centre of this sequence, contained CBM and pottery dating to the mid-16th century. It is notable that the profile of a bank sloping down from the north is still apparent.
- 6.1.9 All overlying deposits are dated to the 19th century or later and are characteristic of large-scale levelling and dumping events. A modern drain (cut 133) appears to use the line of the historic boundary suggesting this is still evident at the time of construction. The latest documentary evidence of the survival of this land division is on the 1839 tithe map of Newbury.

6.2 Trench 2

(See Fig. 4)

- 6.2.1 Trench 2 was positioned in the north-eastern corner of the Marks and Spencers car park. It measured 11 m by 2 m and was orientated east-west. Existing ground level was *c* 75.47 m OD. The trench was initially excavated to a depth of 1.20 m. After recording, a machine dug test pit was excavated to the depth of river gravels.

Stratigraphic description

- 6.2.2 River gravels (213) were encountered at 72.78 m aOD. These were bulk sampled for evidence of lithics. None were retrieved. The river gravels were overlain by a 0.9 m thick peat accumulation (208).
- 6.2.3 Peat layer 208 was capped with a compacted gritty clay, containing calcareous inclusions (207=210), which has been interpreted as purposeful dumping/reclamation (see Trench 1, para 7.1.4). No finds were recovered from this deposit.
- 6.2.4 Layer 207=210 was overlain by a sequence of silts (209, 211+206 (not illustrated) and 205). Pottery retrieved from the base of this sequence suggest a date later than the Late 11th century; pottery from the centre of the sequence (206) was dated to the late 15th century. Cattle, goose and duck bone was also retrieved from this deposit, suggesting domestic dumping as well as silting accumulation.
- 6.2.5 Layer 205 was overlain by a humic 'garden soil' (204) containing pottery dated to the mid 16th century. Fish and cattle bone were also recovered.
- 6.2.6 Deposit 204 was cut through out the trench by the construction of brick structure 203. This structure is likely to be part of a series of brick terrace houses which are shown

to front Marsh Lane on the 1st edition OS map of 1864 and are (less clearly) indicated on the 1839 tithe map of Newbury.

6.3 Trench 3

(See Fig. 4)

- 6.3.1 Trench 3 was positioned immediately to the rear of 25 Northbrook Street. It measured 4.2 m by 2 m and was orientated east-west. Existing ground level was *c* 75.57 m OD. The trench was initially excavated to a depth of 1.2 m. After recording, a machine dug test pit was excavated to the depth of river gravels.

Stratigraphic description

- 6.3.2 River gravels (311) were encountered at 74.72 m aOD. These were bulk sampled for evidence of lithics. None were retrieved. The river gravels were overlain by a 1.4 m thick peat accumulation (310 and 309). Environmental sample 9 (from context 310) contained only rooty and (natural) woody fragments with no other macroscopic plant matter visible.
- 6.3.3 Peat layer 309 was overlain by silt accumulation 308. This contained pottery dating from the late 12th century (at the earliest) as well as pig and cattle bone, indicative of domestic dumping.
- 6.3.4 Deposit 308 was overlain by compacted layer 307 which has been interpreted as a reclamation event (see Trench 1 para 7.1.4). Pottery indicating a late 12th century (or later) date was recovered from this layer. Layer 307 was overlain by a silting/dumping layer (306) which contained pottery dating to the mid 13th century as well as cattle and sheep/goat bones.
- 6.3.5 Layer 306 was overlaid by a 0.6 m thick deposit of clay silt including demolition rubble (304 and 305). This material was identified on-site (not recovered) as 19th century in the upper part of the sequence (304) but was not as clearly recognisable in deposit 305.
- 6.3.6 Deposit 304 was truncated by the construction of the existing hard-standing and overlaid by its related make up deposits (303,302).

6.4 Trench 4

(See Fig. 4)

- 6.4.1 Trench 4 was positioned immediately to the rear of 28 Northbrook Street. It measured 10 m by 2 m and was orientated east-west. Existing ground level was *c* 76.25 m OD. The trench was initially excavated to a depth of 1.2 m. After recording a machine dug test pit was excavated to the depth of river gravels.

Stratigraphic description

- 6.4.2 River gravels (434) were encountered at 72.76 m OD. These were bulk sampled for evidence of lithics. None were retrieved. The river gravels were overlain by a 1.5 m thick peat accumulation (433 and 432).
- 6.4.3 The upper peat deposit (432) was capped by a compacted layer (431) interpreted as a purposeful marshland reclamation event (see Trench 1, para 7.1.4) however no artefacts were retrieved from this deposit.
- 6.4.4 Layer 431 was overlain by a sequence of silts (429, 428, 430, 427 and 426). Pottery ranging from (later than) the late 11th century to the late 12th century was retrieved from this sequence as was sheep/goat and cattle bone. Evidence of burning and possible cess inclusions were also noted. This indicates the sequence represents a series of domestic dump episodes.
- 6.4.5 Layer 426 was overlaid by deposit 415. This was a compacted layer comprising flint and gravel in a clay matrix, characteristic of a yard surface. An intermittent gravel overlying layer 426 (deposit 414) appeared to be patching/maintenance of the surface.
- 6.4.6 All the contexts recorded above surface 426 were related to a modern service pipe (which ran throughout the trench) and brick footings probably relating to buildings first indicated on the 2nd edition 1900 OS map. It is unclear whether the structures are still present on the 1933-34 OS Map.
- 6.5 Trench 5
(See Fig. 5)
- 6.5.1 Trench 5 was positioned at the central-eastern limit of plots 25-28, opposite the Wash and Valet Centre. It measured 9 m by 2 m and was orientated north south. Existing ground level was *c* 75.65 m OD. The trench was initially excavated to a depth of 1.2 m. After recording, a machine dug test pit was excavated to the depth of river gravels.

Stratigraphic description

- 6.5.2 River gravels (531) were encountered at 72.4 m OD. These were bulk sampled for evidence of lithics. None were retrieved. The river gravels were overlain by a 1.3 m thick alluvial sequence comprising clay at the base overlaid by peat deposits (530 and 529, 528 respectively). Flotation of an environmental sample from deposit 530 revealed the layer contained (natural) wood fragments and waterlogged weed seeds. Very good snail preservation was also noted.
- 6.5.3 The upper part of the alluvial sequence (peat 528) was overlaid by deposit 509 (=520, 510, 514). This was a 0.45 m thick re-deposited peat containing CBM and demolition material. Presumably this layer relates to cleaning of the (now culverted) stream which is seen to form the eastern boundary of the site on the Wills 1768 plan of Newbury.

- 6.5.4 Layer 509 was cut at the south end of the trench by the construction of brick arch/wall 518. This feature seems likely to be related to the 18th century culverting of the stream described above, although its orientation is more suggestive of allowing an east-west channel (former burgage plot ditch?) to drain in to the stream.
- 6.5.5 All other features and layers within the trench were associated with the construction of modern brick features (i.e drainage channel 506) and levelling /construction of the existing hard standing.
- 6.6 Trench 6
(See Fig. 5)
- 6.6.1 Trench 6 was positioned in the car park immediately to the rear of 30-31 Northbrook Street. It measured 4.5 m by 2 m and was orientated north south. Existing ground level was *c* 75.69 m OD. The trench was initially excavated to a depth of 1.2 m. Hand excavation was carried out in order to clarify and date the horizontal stratigraphic sequence. After retrieval of finds and recording, a machine dug test pit was excavated to the depth of river gravels.

Stratigraphic description

- 6.6.2 River gravels (615) were encountered at 72.69 m aOD. These were bulk sampled for evidence of lithics. None were retrieved. The river gravels were overlain by a 1.4 m thick sequence of peat deposits (614 and 612).
- 6.6.3 Peat deposit 612 was overlaid by a silt deposit (611). This in turn was overlaid by a compacted silt (610) interpreted as representing purposeful marshland reclamation (see Trench 1, para 7.1.4). Pottery was retrieved from this layer indicating a deposition date after the late 12th century. Cattle, pig and sheep/goat bones were also recovered.
- 6.6.4 Layer 610 was overlaid with a 0.35 m thick clay-silt deposit (609). This contained pottery dated to the mid 16th century as well as cattle bone and may be equivalent to the imported humic garden soil seen elsewhere on site dating to this period (although less obviously a worked soil). Two layers (608 and 607) overlying deposit 609 appeared to be dumped/levelling/demolition deposits, containing some building material and also pottery dating to the mid 16th century.
- 6.6.5 All other contexts in the trench were modern and related either to a brick drain seen at the north end of the trench or to the formation of the existing car park.
- 6.7 Trench 7
(See Fig. 6)
- 6.7.1 Trench 7 was positioned in the north eastern corner of the car park to the rear of 30-31 Northbrook Street. It measured 15 m by 2 m and was orientated east-west. Existing ground level was *c* 75.28 m OD. The trench was initially excavated to a depth of 1.2 m. After recording a machine dug test pit was excavated to the depth of river gravels.

Stratigraphic description

- 6.7.2 River gravels (723) were encountered at 72.51 m aOD. These were bulk sampled for evidence of lithics. None were retrieved. The river gravels were overlain by a 1.4 m thick peat deposit (720).
- 6.7.3 Peat deposit 720 was cut into the centre of the trench by a large pit (cut 722). This contained abundant sheep/goat bones (many evidencing knife marks) as well as leather fragments and pottery, indicating a 15th century date for the feature. The feature was characteristic of dumping associated with tanning works.
- 6.7.4 The upper fills of pit 722 (silts 718 and 716) were sealed by silt layer 715. Cattle bone was recovered from this deposit.
- 6.7.5 A line of wooden stakes (721) were driven into layer 715 and roughly formed an east west line, possibly demarcating or running parallel to a burgage plot boundary.
- 6.7.6 Through out the trench, layer 715 was overlaid by a series of levelling/dumping deposits (712, 713, 710, 711, 704, 709, 708, 707, 705 and 703) which contained fragments of CBM and occasional burnt patches. These deposits were not dated but are likely to relate to late landscaping of the area. This sequence was capped with deposits relating to the existing car park (702 and 701).
- 6.8 Trench 8
(See Fig. 6)
- 6.8.1 Trench 8 was positioned in the south eastern corner of the car park to the rear of 36-37 Northbrook Street. It measured 4 m by 2 m and was orientated east-west. Existing ground level was *c* 75.08 m OD. The trench was initially excavated to a depth of 1.2 m. After recording, a machine dug test pit was excavated to the depth of river gravels.

Stratigraphic description

- 6.8.2 River gravels (824) were encountered at 72.45 m aOD. These were bulk sampled for evidence of lithics. None were retrieved. The river gravels were overlain by a 0.7 m thick alluvial sequence comprising a layer of clay-silts immediately above the gravels (823) and two peat layers (822 and 814). An environmental sample from layer 823 contained (natural) wood fragments, waterlogged weed seeds and limited fragmentary insect remains. Flecks of calcium precipitates were also apparent in the flotation residue.
- 6.8.3 The upper part of the alluvial sequence (deposit 814) was cut by a shallow pit (cut 821). This feature was at least 0.50 m in diameter and was filled with a series of silts (812, 813, 825 and 820). Fill 812 contained pottery giving an earliest date of late 11th century for this feature, as well as horse bone.
- 6.8.4 The upper fills of pit 821 (820 and 825) were partially removed by pit cut 825. This was a slightly smaller pit filled by a two silt deposits (811, 810) containing

sheep/goat, cattle and horse bone as well as a range of ceramics indicating a late 12th century date for the feature.

6.8.5 The upper fill of pit 825 (810) was sealed by a series of landscaping/dumping demolition layers (809, 808, 807, 806, 805, 818, 804, 815 803, and 819). Pottery retrieved from these layers indicate the mid 16th century as the earliest possible for their deposition.

6.8.6 The sequence described above was cut into by an 18th-19th century wall foundation (817) and overlaid by deposits relating to construction of the existing car park.

6.9 Trench 9
(See Fig. 7)

6.9.1 Trench 9 was positioned in the north eastern corner of the car park to the rear of 36-37 Northbrook Street. It measured 4.7 m by 2 m and was orientated east-west. Existing ground level was *c* 75.05 m OD. The trench was initially excavated to a depth of 1.2 m. After recording, a machine dug test pit was excavated to the depth of river gravels.

Stratigraphic description

6.9.2 River gravels (924) were encountered at 71.83 m aOD. These were bulk sampled for evidence of lithics. None were retrieved. The river gravels were overlain by a 1.50 m thick alluvial sequence comprising a layer of clay-silts immediately above the gravels (923) and two peat layers (922 and 921).

6.9.3 The upper part of the alluvial sequence was severely truncated through out the trench by a large pit (920) containing 19th century pottery and demolition material (see fig for numbers). Subsequent to infilling, this feature was overlaid with an imported garden soil (906) and 19th century brick footings and deposits relating to the existing car park.

6.10 Trench 10
(See Fig. 7)

6.10.1 Trench 10 was positioned in the central part of the car park to the rear of 38 Northbrook Street. It measured 8 m by 2 m and was orientated east-west. Existing ground level was *c* 72.4 m OD. The trench was initially excavated to a depth of 1.2 m. After recording, a machine dug test pit was excavated to the depth of river gravels.

Stratigraphic description

6.10.2 River gravels (1017) were encountered at 68.80 m aOD. These were bulk sampled for evidence of lithics. None were retrieved. The river gravels were overlain by a 1.70 m thick alluvial sequence comprising a layer of clay-silts immediately above the gravels (1016) and two peat layers (1015 and 1007). Flotation of an environmental sample from context 1016 contained (natural) woody fragments, waterlogged weed seeds and

fragmentary insect remains. Tufaceous calcium precipitates were apparently forming *in situ* on woody elements in the sample.

- 6.10.3 The upper part of the alluvial sequence (1007) was overlain by a series of silts (1014, 1009 and 1006). Layer 1008 contained pottery indicating a late 12th century (or later) date for deposition. Layer 1006 contained sheep/goat, cattle and pig bone.
- 6.10.4 Layer 1008 was cut to the east of the trench by pit 1013. This feature was at least 0.8 m in diameter and 0.26 m deep. The pit was filled with a series of dump deposits (1012, 1011 and 1010). The range of ceramics retrieved from these indicated a mid 16th century date for the feature. Sheep/goat, pig and cattle bone and ceramic building material was also retrieved from the fills.
- 6.10.5 The upper fill (1010) of pit 1013 was overlain by a redeposit alluvial clay (1105). This contained residual medieval pottery, as well as well preserved charred plant remains and abundant snails (see section 7.1.2 palaeo-environmental remains). This layer was in turn overlaid by a sequence of 19th century landscaping/dump layers and deposits relating the construction of the existing hardstanding.

6.11 Finds

Pottery (See Appendix 4)

- 6.11.1 The pottery assemblage comprised 257 sherds with a total weight of 5729 g. The range of fabrics, which is typical of sites in and around Newbury, indicates that there was activity at the site from the early medieval period until the present day.
- 6.11.2 The range of fabrics suggest that activity at this site started at some time around the end of the 11th century, and continued unabated until the present day. All the major local medieval and post-medieval wares are present, along with regional medieval imports from the lower Thames Valley, such as London and Surrey wares. It is comparable to the range of pottery from other excavations in Newbury (e.g. Mepham 1997), and shows a similar chronology.
- 6.11.3 The earlier medieval assemblage is fairly fragmented, with the range of vessels comprising jars, bowls and jugs, with the first-named by far the most common. By the late medieval period, a wider range of vessels, with items such as cups begins to appear. This is typical of sites of the period in the region.
- 6.11.4 There is some residuality, with medieval wares occurring in post-medieval contexts, but generally the assemblage is well-stratified, with the pottery generally showing little evidence of redeposition.
- 6.11.5 The pottery occurrence by number and weight of sherds per context by fabric type is shown in Appendix 3. Each date should be regarded as a *terminus post quem*.

Ceramic building material (See Appendix 5)

6.11.6 The majority of the assemblage contained examples of medieval brick and roof tile with only a small quantity of underfired material. A significant proportion of the ceramic assemblage showed typical evidence of medieval roof tile manufacture within a residual context. The bulk of the assemblage was of medieval ceramic roof tile that included pegged tiles and ridge tiles, both plain and glazed. The flat roof tile could be broken down into at least two further types (Type 1 and Type 2). The exceptionally small brick assemblage of 27 fragments contained only 6 fragments with diagnostic traits the remainder being non-diagnostic.

Flint

6.11.7 A total of three pieces of worked flint (see *table below*) and 16 pieces of burnt unworked flint were recovered from the evaluation. The worked flint includes two chips and one piece of irregular waste. The residues from environmental sampling were scanned for the presence of worked flint, in particular microdebitage. Some small chips were present but not retained. The material may relate to Prehistoric activity, however, the lack of genuine flakes and the abundance of naturally fractured flint in the samples suggests it is likely to be natural.

Summary of worked flint

Context	512	718	909	Total
Chip	1		1	2
Irregular waste		1		1
Total	1	1	1	3

Summary of burnt unworked flint

Context	Count	Weight
128	1	2
129	2	2
426	1	1
609	1	12
610	2	43
611	4	176
808	4	3
1006	1	18
Total	16	257

Coal

6.11.8 One piece of coal was recovered from context 916.

Shell

6.11.9 A total of 25 fragments of oyster shell were recovered from the site. The table below gives the quantifications for each context.

Context	Fragment count	Weight (g)
103	3	37
104	1	12
204	1	36
305	4	70
426	2	11
512	2	7
607	2	37
809	1	8
810	2	28
908	2	36
909	2	35
910	2	30
1006	1	15

Clay Pipes

6.11.10 Twelve pieces of clay pipe weighing 40g were recovered. These comprise one mouthpiece fragment and eleven pieces of stem. No pipe bowls were recovered although one of the stamped stems (context 910) has a short spur and a trace of bowl attached. Although stems are of limited use for dating, most of the stems here appear to be of 17th and 18th century date with one stem perhaps dating to the 18th to early 19th century. The assemblage would be quite unremarkable but for the presence of two separate stems with stamped circular makers' marks. These appear, on the basis of published parallels, to be of late 17th to early 18th century date, although the marks themselves are unidentified. Neither stamp is completely legible due to incomplete stamping of the die. That from context 607, on a plain stem, appears to be something like a merchant's mark - possibly a saltire cross - incorporating the initials 'C' or 'G' above the letter 'B', on the left side of the stamp. That from context 910, on the upper side of the spurred stem, appears to consist solely of lettering within a (very faint) stamped circle. It appears to contain the maker's name '(R)ICH(A)RD.S-----R'. Neither of these stamps can be paralleled in Oswald's 1975 study of British clay pipes. Stamps on spurs are generally rare so it is unusual to find two within the same small assemblage. The pipes appear to represent domestic refuse.

Context	Spot-date	Stem	Bowl	Mouth	Tot sherds	Tot Wt	Comments
104	17-E18C	2	0	0	2	8	Stem bores c3mm
204	17-E18C	1	0	0	1	8	Stem bore c3mm

503	18C?	1	0	0	1	2	Stem bore c2mm
512	18C?	1	0	0	1	4	Stem bore c2mm
607	L17- E18C?	1	0	0	1	5	Stem bore c2mm. Circular stamp on stem circular - unidentified. Possibly merchant's mark with ?saltire cross in circle & incuse 'B' lower left with trace of another letter (C or G?) above this
908	18C?	1	0	1	2	2	Stem bore c2mm. Same pipe?
909	18- E19C?	2	0	0	2	3	Stem bores 1.5-2mm
910	L17- E18C?	1	0	0	1	4	Stem bore 2.25mm with trace of bowl & complete short spur. Circular stamp on stem – unidentified. Contains incuse name '(R)ICH(A)RD.S-----R'.
918	17-E18C	1	0	0	1	4	Stem bore 2.75mm
TOTAL		11	0	1	12	40	

6.12 Palaeo-environmental remains

Waterlogged Plant Remains

6.12.1 The peat samples all produced large waterlogged flots in the region of 1 litre. The samples appeared to consist of homogenous peat-however there were some differences in the degree of preservation of organic matter. Samples 9 (context 310) and 14 (context 152) contained only rooty and woody fragments with no other macroscopic plant matter visible. Samples 24 (context 530), 34 (context 1016) and 20 (context 823) all contained woody fragments and waterlogged weed seeds. In addition samples 34 context (1016), sample 15 (context 157) and sample 20 (context 823) contained limited fragmentary insect remains. Tufaceous calcium precipitates were apparently forming in situ on woody elements in sample 34 (context 1016), which flecks of calcium precipitates were apparent in the flot of sample 20 (context 823).

6.12.2 *Charred Plant Remains*

6.12.3 Dump deposit (sample 31, context 1005) produced a reasonably sized flot of 150ml. The majority of the flot was composed of charcoal, with frequent items >2mm and therefore with potential to be identified to species level. Chaff, in the form of glume bases, was also frequent in the flot as was one item of Gramineae cereal grain of indeterminate genus. Snails were also common in this flot, with a range of taxa represented. Shells were extremely well preserved, comprising almost entirely dry terrestrial species, apart from the occasional fresh water slum species *Lymnaea* sp cf *truncatula*. The terrestrial species are overwhelmingly dominated by shade demanding species, various zonotids, *Discus rotundatus*, along with significant numbers of catholic species, particularly *Trichia* sp. Open country species were also present in low number mainly, *Vallonia costata*.

6.12.4 *Artefacts and small bones*

6.12.5 The residues from all the samples were sorted for artefacts and small bones. Ceramic building material (CBM) and pottery were recovered from samples 29 (context 224)

and 17 (context 129). There was no definitively anthropogenic worked larger flints (>4mm). Five sherds of 12-13th century pottery were recovered from sample 17 (context 129). Bone and pottery as well as larger fragments of charcoal were recovered from the dump deposit (sample 31, context 1005). Sizeable tufaceous material was recovered from a number of residues-some evidently formed around organic material including woody plant matter and on some gravel.

6.12.6 Discussion

6.12.7 Wet sieving the gravel deposits was designed to explore the possibility of early prehistoric flint scatters underlying the peat. A total of 4 flakes from the larger fractions of 2 two samples (sample 17, context 129 and sample 10 context 311) were regarded as possibly anthropogenic struck flints. However the flakes were generally rolled and of indistinct origin. No clear early prehistoric flaked material from the site has been identified.

6.12.8 The charred plant remains had the potential for further analysis to develop understanding of fuel resources on the site. However there was little other evidence of ecological or economic indicators from this sample. The sample does illustrate the potential for large and complex charred deposits on the site.

6.12.9 The preservation of the waterlogged ecofactual material was fairly poor. The majority of the material was woody or rooty plant matter, with limited volumes of seeds or insect matter and no leaf matter. This suggests that the peat was relatively well humified. There is potential for further analysis work on several of these samples, particularly samples 24 (context 530), 34 (context 1016) and 20 (context 823) to provide identifications and interpretations of the waterlogged plant macro remains. The degree of humification of the deposits also suggests that pollen might be well preserved in all of these samples.

6.12.10 Further work at the site should take into account the potential to utilise the diverse forms of ecofactual evidence apparently available, including waterlogged assemblages, charred deposits, pollen and diatom or ostracod evidence if alluvial sequences are encountered. Although the peat deposits appear well humified the tufaceous deposits mean that there are localised highly calcareous deposits within the profile, this results in very good snail preservation in certain profiles (such as sample 24, context 530), snail samples may also therefore be appropriate.

Animal bone (See Appendix 6)

6.12.11 A medieval and post-medieval animal bone assemblage from this urban site in Newbury includes the remains of domestic mammals, birds and fish. The assemblage generally is suggestive of the disposal of general refuse but one context (15th century) of sheep or goat metapodials may be waste from industrial activity such as leather tanning.

7 DISCUSSION AND INTERPRETATION

7.1 Reliability of field investigation

7.1.1 The evaluation represents a small sample (some 1%) of the proposed development area and therefore the results can only be an indication of the potential for survival of archaeological remains and their presence where encountered. The absence within the development area of medieval structural remains or further evidence of industrial activity as well as timber structures and prehistoric remains associated with the underlying alluvial sediments cannot be inferred from this evaluation.

7.1.2 Overall interpretation

7.1.3 The evaluation has shown that stratified deposits dating from potentially the mesolithic period to the 16th century survive across the proposed development area. Only in one instance (Trench 9) was significant impact from modern construction recorded.

7.1.4 No archaeological remains associated with the alluvial deposits that underlie the site were found. However the investigation sample was small in relation to the area of the proposed development. The evaluation has highlighted the potential for environmental reconstruction of the alluvial sequence either in relation to archaeological remains (should any be encountered in future works) or in order to inform geoarchaeological modelling of the site's prehistoric evolution.

7.1.5 The evaluation recorded evidence of the medieval establishment and maintenance of burgage plot boundaries, possible formal reclamation of the marshland environment, yard surfaces and evidence of tanning waste. Evidence of 16th century landscaping and construction related deposits were also found across the site. A brick structure seen in Trench 5 may relate to 19th century culverting of the stream that formed the eastern boundary of the site.

7.2 Summary of results

7.2.1 For ease of reference significant archaeological deposits and structures within each trench have been tabulated below.

Trench	Comments	Date
1	River gravels	Undated
	Alluvial sediment sequence	Mesolithic (?) - medieval
	Medieval reclamation	Late 12th century (?)
	Medieval boundary ditch	Late 12th-14th century

Trench	Comments	Date
2	River gravels	Undated
	Alluvial sediment sequence	Mesolithic (?) - medieval
	Medieval reclamation and silting	Late 12th century (?)
3	River gravels	Undated
	Alluvial sediment sequence	Mesolithic (?) - medieval
	Medieval reclamation	Late 12th century (?)
4	River gravels	Undated
	Alluvial sediment sequence	Mesolithic (?) - medieval
	Medieval reclamation and silting	Late 11th century (?)
	Medieval dumping, yard surfaces	Late 12th century (?)
5	River gravels	Undated
	Alluvial sediment sequence	Mesolithic (?) - medieval
	Brick wall and culvert	19th century
6	River gravels	Undated
	Alluvial sediment sequence	Mesolithic (?) - medieval
	Medieval reclamation and silting	Late 12th century (?)
7	River gravels	Undated
	Alluvial sediment sequence	Mesolithic (?) - medieval
	Medieval reclamation	Late 12th century (?)
	Medieval tanning waste pit	15th century
8	River gravels	Undated
	Alluvial sediment sequence	Mesolithic (?) - medieval
	Medieval pits	L11th -12th
9	River gravels	Undated
	Alluvial sediment sequence	Mesolithic (?) - medieval
10	River gravels	Undated

Trench	Comments	Date
	Alluvial sediment sequence	Mesolithic (?) - medieval
	Medieval silting	Late 12th century (?)
	Pit	16th century

8 IMPACT OF THE DEVELOPMENT

- 8.1.1 A statement on the impact of the development as well as proposals for mitigation are contained within the EIA submitted in relation to this development.

APPENDICES

APPENDIX 1 ARCHAEOLOGICAL CONTEXT INVENTORY

<i>Trench</i>	<i>Ctxt No</i>	<i>Type</i>	<i>Comment</i>	<i>Finds</i>
001				
	101	Layer	Modern organic dump layer	Pot, bone, CBM
	102	Layer	Dump deposit	
	103	Layer	Clay silt	Pot bone CBM
	104	Layer	Clay silt	Pot bone CBM
	105	Layer	Lens of chalk	
	106	Layer	Clay silt	
	107	Layer	Dump deposit	
	108	Layer	Imported (?) garden soil	
	109	Layer	Rubble/silt	
	110	Cut	Modern pit - function unknown	
	111	Fill	Fill of 111	
	112	Cut	Modern pit cut	
	113	Fill	Demolition material fill of 112	
	114	Layer	Car park make-up	
	115	Layer	Car park make-up	
	116	Layer	Car park tarmac	
	117	Layer	Car park make-up	
	118	Cut	Modern service trench	
	119	Fill	Fill of 118	
	120	Fill	Fill of 118	
	121	Fill	Fill of 118	
	122	Layer	Car park make-up	
	123	Layer	Car park make-up	
	124	Layer	Car park tarmac	
	125	Layer	Clay silt	
	126	Layer	Peat	

<i>Trench</i>	<i>Ctxt No</i>	<i>Type</i>	<i>Comment</i>	<i>Finds</i>
	127	Layer	Clay silt	Pot bone CBM
	128	Layer	Clay silt	CBM
	129	Layer	Fluvial sand (?)	Pot bone
	130	Layer	Peat	
	131	Layer	Clay silt	
	132	Fill	Primary fill of 143	
	133	Cut	Modern service cut	
	134	Fill	Fill of 133	Pot
	135	Fill	Fill of 133	
	136	Fill	Clay fill of 143	
	137	Fill	Clay fill of 143	
	138	Fill	Fill of 156	
	139	Fill	Fill of 156	
	140	Fill	Fill of 156	
	141	Cut	Linear (?) feature	
	142	Fill	Fill of feature 141	Pot
	143	Cut	Pit (?)	
	144	Layer	Peat	
	145	Fill	Primary fill of 150	
	146	Layer	Sandy clay	Bone
	147	Layer	Peat/sand	
	148	Fill	Fill of 150	
	149	Layer	Sandy clay	
	150	Cut	Linear (?) feature	
	151	Layer	Lens of sandy clay	
	152	Layer	Peat	
	153	Layer	Gravelly sand	
	154	Layer	Same as 103	
	155	Layer	Re-deposited peat	
	156	Cut	Linear (?) feature	
	157	Layer	Peat	
	158	Layer	Fluvial gravel	

<i>Trench</i>	<i>Ctxt No</i>	<i>Type</i>	<i>Comment</i>	<i> Finds</i>
002				
	201	Layer	Car park tarmac	
	202	Layer	Make-up for 201	
	203	Structure	Brick wall	
	204	Layer	Garden soil	Pot bone
	205	Layer	Alluvium	Bone CBM
	206	Layer	Mixed dump deposit	Pot bone CBM
	207	Layer	Dump deposit	
	208	Layer	Peat	
	209	Layer	Clay silt accumulation	Pot
	210	Layer	Dump deposit	
	211	Layer	Clay silt accumulation	
	212	Cut	Construction cut	
	213	Layer	Fluvial river gravel	
003				
	301	Layer	Car park tarmac	
	302	Layer	Concrete	
	303	Layer	Make up for 301/2	
	304	Layer	Mixed modern dumping	
	305	Layer	Mixed modern dumping	Bone CBM
	306	Layer	Dump deposit	Pot bone CBM
	307	Layer	Dump deposit	Pot
	308	Layer	Clay silt accumulation	Pot bone
	309	Layer	Peat	
	310	Layer	Peat	
	311	Layer	Fluvial river gravel	
004				
	401	Layer	Demolition and levelling layer for car park	
	402	Fill	Fill of modern service	

<i>Trench</i>	<i>Ctxt No</i>	<i>Type</i>	<i>Comment</i>	<i>Finds</i>
	403	Structure	Modern brick wall	
	404	Deposit	Clay lining for 403	
	405	Layer	Make up layer	
	406	Layer	Demolition and levelling deposit	
	407	Cut	Sewage pipe cut	
	408	Cut	Construction cut for 403	
	409	Layer	Car park tarmac	
	410	Layer	Levelling layer for 417	
	411	layer	Make up layer	
	412	Layer	Levelling layer	
	413	Layer	Tile floor surface	
	414	Layer	Dumped gravel deposit	
	415	Layer	Yard(?) surface	
	416	Layer	Demolition deposit	
	417	Layer	Tile floor surface	
	418	Cut	Construction cut for 425	
	419	Void No.		
	420	Fill	Fill of 408	
	421	Layer	Modern dumping /make up	
	422	Layer	Modern dumping /make up	
	423	Fill	Fill of 408	
	424	Fill	Slag rich fill of 408	
	425	Structure	Brick foundation	
	426	Layer	Humic clay	Pot bone CBM
	427	Layer	Clay silt accumulation	
	428	Layer	Clay silt accumulation	Pot CBM
	429	Layer	Clay silt accumulation (containing burnt soils)	
	430	Layer	Clay silt containing possible cess material	
	431	Layer	Dump deposit	
	432	Layer	Peat	

<i>Trench</i>	<i>Ctxt No</i>	<i>Type</i>	<i>Comment</i>	<i> Finds</i>
	433	Layer	Peat	
	434	Layer	Fluvial river gravel	
005				
	501	Layer	Car park tarmac	
	502	Layer	Make up for tarmac	
	503	Layer	Make up for tarmac	Pot CBM
	504	Fill	Fill of 505	
	505	Cut	Construction cut for	
	506	Structure	Brick soak-away	
	507	Layer	Clay silt accumulation	
	508	Layer	Clay silt accumulation	
	509	Layer	Clay silt/building debris	CBM
	510	Layer	Dump deposit	
	511	Cut	Construction cut for 518	
	512	Fill	Fill of 511	Pot bone, worked flint CBM
	513	Fill	Fill of 511	Pot CBM
	514	Layer	Re-deposited peat	
	515	Layer	Levelling layer for 518	
	516	Void No.		
	517	Void No.		
	518	Structure	Brick wall and culvert	
	519	Void No.		
	520	Fill	Fill of 505	
	521	Cut	Construction cut for 518 (same as 510)	
	522	Fill	Fill of 521	
	523	Fill	Fill of 521	
	524	Fill	Fill of 510	
	525	Layer	Re-deposited garden soil	
	526	Layer	Levelling for 506	

<i>Trench</i>	<i>Ctxt No</i>	<i>Type</i>	<i>Comment</i>	<i>Finds</i>
	527	Fill	Fill of 505	
	528	Layer	Peat	Bone
	529	Layer	Peat	
	530	Layer	Alluvial clay	
	531	Layer	Fluvial gravel	
006				
	601	Layer	Car park tarmac	
	602	Layer	Make up for 601	Pot
	603	Fill	Fill of 604	
	604	Structure	Brick drain	
	605	Cut	Construction cut for 604	
	606	Layer	Make up deposit	
	607	Layer	Clay silt accumulation	Pot bone CBM
	608	Layer	Demolition deposit	
	609	Layer	Clay silt accumulation	Pot bone CBM
	610	Layer	Dump deposit	Pot bone
	611	Layer	Clay silt accumulation	
	612	Layer	Peat	
	613	Layer	Alluvium mixed with demolition material	
	614	Layer	Peat	
	615	Layer	Fluvial river gravels	
007				
	700	Layer	Car park tarmac	
	701	Layer	Make up for 701	
	702	Layer	Re-deposited peat	
	703	Layer	Re-deposited peat	
	704	Layer	Re-deposited peat	
	705	Layer	Levelling layer	
	706	Layer	Levelling layer associated with 700	
	707	Layer	Levelling layer	

<i>Trench</i>	<i>Ctxt No</i>	<i>Type</i>	<i>Comment</i>	<i> Finds</i>
	708	Layer	Clay silt accumulation	
	709	Layer	Levelling layer	
	710	Layer	Levelling layer	
	711	Layer	Silt accumulation	
	712	Layer	Silt accumulation	
	713	Layer	Dump deposit	
	714	Layer	Silt accumulation	
	715	Layer	Silt accumulation	Bone
	716	Deposit	Ashy lens	
	717	Layer	Peat	
	718	Layer	Fill of 722	Pot bone worked flint CBM
	719	Layer	Fill of 722	Pot
	720	Layer	Peat	Bone
	721	Structure	Line of stakes	
	722	Cut	Pit cut	
008				
	801	Layer	Car park tarmac	
	802	Layer	Modern made ground	
	803	Layer	Demolition layer	Pot CBM
	804	Deposit	Clay lining for wall 817	Pot
	805	Layer	Clay silt accumulation	
	806	Layer	Modern made ground	
	807	Layer	Compact clay silt (PM levelling?)	CBM
	808	Layer	Compact clay silt (PM levelling?)	Pot bone CBM
	809	Layer	Compact clay silt (PM levelling?)	Pot bone CBM
	810	Fill	Fill of pit 825	Pot bone CBM
	811	Fill	Fill of pit 825	Pot

<i>Trench</i>	<i>Ctxt No</i>	<i>Type</i>	<i>Comment</i>	<i> Finds</i>
				CBM
	812	Fill	Fill of pit/ditch 821	Pot
	813	Fill	Fill of pit/ditch 821	
	814	Layer	Peat	
	815	Layer	Silt	
	816	Cut	Construction cut for wall 817	
	817	Structure	Brick wall	
	818	Layer	Modern made ground	
	819	Layer	Clay silt accumulation	
	820	Fill	Fill of pit/ditch 821	
	821	Cut	Pit/ditch	
	822	Layer	Peat	
	823	Layer	Peaty- clay alluvium	
	824	Layer	Fluvial gravel	
	825	Cut	Pit	
	826	Fill	Fill of pit/ditch 821	
009				
	901	Layer	Car park tarmac and concrete	
	902	Layer	Modern made ground	
	903	Layer	Modern made ground	
	904	Structure	Brick wall	
	905	Cut	Construction cut for wall 904	
	906	Layer	Garden soil	
	907	Layer	Garden soil	Pot
	908	Fill	Fill of pit 920	Pot CBM
	909	Fill	Fill of pit 920	Pot worked flint CBM
	910	Fill	Fill of pit 920	Pot bone CBM
	911	Fill	Fill of pit 920	
	912	Fill	Fill of pit 920	

<i>Trench</i>	<i>Ctxt No</i>	<i>Type</i>	<i>Comment</i>	<i> Finds</i>
	913	Fill	Fill of pit 920	
	914	Fill	Fill of pit 920	
	915	Fill	Fill of pit 920	Pot bone CBM
	916	Fill	Fill of pit 920	Pot bone CBM
	917	Fill	Fill of pit 920	
	918	Fill	Fill of pit 920	Pot
	919	Layer	Silt dump	
	920	Cut	PM pit	
	921	Layer	Peat	
	922	Layer	Peat	
	923	Layer	Peat/gravel	
	924	Layer	Fluvial gravel	
010				
	1001	Layer	Car park tarmac	
	1002	Layer	Modern made ground	Pot CBM
	1003	Layer	Modern made ground	Bone CBM
	1004	Layer	Modern made ground	Pot
	1005	Layer	Re-deposited (?) alluvium	Pot bone CBM
	1006	Layer	Clay alluvium	Pot bone CBM
	1007	Layer	Peat	
	1008	Layer	Clay alluvium	
	1009	Layer	Fluvial (?) sand	
	1010	Fill	Fill of pit 1013	Pot
	1011	Fill	Fill of pit 1013	Pot bone CBM
	1012	Fill	Fill of pit 1013	Pot
	1013	Cut	Pit	
	1014	Layer	Peat	

<i>Trench</i>	<i>Ctxt No</i>	<i>Type</i>	<i>Comment</i>	<i>Finds</i>
	1015	Layer	Peat	
	1016	Layer	Peat	
	1017	Layer	Fluvial gravel	

APPENDIX 2 BIBLIOGRAPHY

- BARAS 2003 *Desk-Top Assessment of Park Way Newbury. Report No.1178. Unpublished client report.*
- OA 2000 *Parkway Redevelopment Newbury Archaeological Desk-top assessment. Unpublished client report.*
- OA 2005A *Camp Hopson Department Store 6-12 Northbrook Street Newbury Berkshire. Unpublished client report.*
- OA 2005B *Newbury Historic Character Study Assessment Report. Unpublished client report.*
- OA 2005C *Newbury Parkway Project Design for Phase 1 evaluation*

APPENDIX 3 SUMMARY OF SITE DETAILS**Site name:** Newbury Parkway Phase 1**Site code:** NEWPP105**Grid Reference:** NGR SU 471 673**Type of evaluation:** Trial trench**Date and duration of project:** 15/08/05 to the 08/09/05**Summary of results:**

The evaluation revealed an intact sequence of alluvial sediments comprising clays and peats overlying the gravel terrace of the River Kennet. No archaeological remains were found associated with these deposits. However the evaluation sample size was low in relation to the overall investigation area. Preservation of environmental indicators within this sequence was generally good.

The alluvial sequence was cut into by evidence of land demarcation (a maintained/re-cut burgage plot ditch) to the south west of the site. Pottery retrieved from these features indicated a date after the late 12th Century.

Much of the investigation area appeared to have been subject to formal reclamation (from marshland) in the late 12th century. This was evidenced by a distinct compacted layer that appeared in many of the trenches capping the peat which formed the upper part of the alluvial sequence. Yard surfaces found immediately to the rear of Northbrook Street are also likely to date from this period, as was a pit to the eastern side of the site.

Subsequent to the reclamation deposit a gradual accumulation of deposits through dumping and silting was recorded in many of the trenches. A probable tanning waste pit dated to the 15th century was recorded to the central eastern part of the site.

Importation of garden soil in the middle 16th century was noted across the site, as well as pits related to construction during this period

A brick structure which most likely relates to 19th century culverting of a stream which formed the eastern boundary of the site was recorded.

Location of archive: The archive is currently held at OA, Janus House, Osney Mead, Oxford, OX2 0ES, and will be deposited with West Berkshire Heritage Services in due course, under the site code NEWPP105.

APPENDIX 4 POTTERY

By Paul Blinkhorn

The pottery assemblage comprised 257 sherds with a total weight of 5729 g. The range of fabrics, which is typical of sites in and around Newbury, indicates that there was activity at the site from the early medieval period until the present day.

Fabrics

The following fabric types were noted:

Newbury 'B' ware: Late 11th – late 14th century (Mephram 1997, 51-2). A range of sand-, flint- and limestone-tempered wares. Sparse to moderate limestone up to 2mm, rounded white or clear quartz up to 0.5mm, angular fragments of white, grey or black flint. Jars, bowls and pitchers. 83 sherds, 1,068 g.

Newbury 'C' ware: Late 12th – mid 14th century (Mephram 1997, 52-4). Dense sub-rounded white quartz up to 1mm, rare rounded red ironstone up to 1mm. Jars, bowls, tripod pitchers and slipped and glazed jugs. 36 sherds, 439 g.

London ware: c. 1150-1350 (Pearce et al., 1985). Sandy ware, common in small quantities throughout the Home Counties, and at more distant locations such as Exeter, King's Lynn, Ipswich, Northampton, Hereford, Gloucester and the east coast of Scotland (ibid. 6-7 and figs. 4 and 5). Source unknown, but likely to be close to the City of London, where it occurs in extremely large quantities. The jug was by far the most common form, and these were often highly decorated, sometimes copying imported pottery from Northern France. 1 sherd, 5 g.

Brill/Boarstall Ware: c. AD1200-?1600 (Mellor 1994). Wheel-thrown. Hard buff, orange, pale pink, or yellow-grey fabric, sometimes with fine 'pimpley' surface. Rare to common sub-angular to sub-rounded orange, clear and grey quartzite up to 0.5mm, rare subrounded to sub-angular red ironstone up to 1mm. Mottled pale to dark glossy green exterior glaze, often with copper filings. 1 sherd, 16g.

Surrey Whiteware: c. 1250-1450. (Pearce and Vince 1988). White fabric with abundant, well sorted iron-stained, pink, white and clear quartz, sparse to moderate red and black ironstone. Mainly jugs with a rich copper-green glaze, often highly decorated with incised and applied decoration and iron-rich slip. 4 sherds, 19g

'Tudor Green' Wares: c AD1380-1500. Green-glazed whitewares produced at several centres in the south of England, such as Farnborough Hill, Hants (Pearce and Vince 1988). 1 sherd, 9 g.

German Stonewares: AD1480+. A range of hard, grey, salt-glazed fabrics produced at numerous sites in the Rhineland and beyond (Gaimster 1997). 2 sherds, 9 g.

Cistercian Ware: c AD1470-1550 (McCarthy and Brooks 1988). Hard, smooth fabric, usually brick-red, but can be paler or browner. Few visible inclusions, except for occasional quartz grains. Range of vessel forms somewhat specialised, and usually very thin-walled (c 2mm). Rare white slip decoration. 4 sherds, 23 g.

Red Earthenwares: Mid 16th century +. Fine sandy earthenware, usually with a brown or green glaze, occurring in a range of utilitarian forms. Such 'country pottery' was first made in the 16th century, and in some areas continued in use until the 19th century (McCarthy and Brooks 1988). 53 sherds, 2,722 g.

Border Wares: Mid 16th – 18th century. Generic term for the post-medieval pottery industry of the Hampshire/Surrey border area (Pearce 1992). The range of fabrics comprised fine, sandy whitewares with an off-white to buff fabric and with yellow, green olive or brown glaze, and fine redwares with clear green to olive or brown glaze. The manufacture of whitewares ceased during the 18th century. Produced a wide range of late medieval and early post-medieval vessel types. 3 sherds, 38 g.

Tin-Glazed Earthenwares: c. AD1550-1700. Fine white earthenware, occasionally pinkish or yellowish core. Thick white tin glaze, with painted cobalt blue decoration, occasionally manganese purple and ochre (Orton 1988). 1 sherd, 16 g.

Staffordshire Slipware: AD1640-1750. Fine cream fabric with white slip and pale yellow lead glaze, commonest decoration is feathered dark brown trailed slip. Chiefly press-moulded flat wares, although small bowls and mugs etc are known. 1 sherd, 12 g.

Staffordshire Manganese Mottled Ware: late 17th – 18th century (Barker 1999). Fine, buff fabric, with vessels usually covered with a mottled purple and brown glaze, which is generally lighter on the more modern examples. A wide range of domestic vessel forms, but mugs and chamber pots are particularly common. 2 sherds, 105 g.

Staffordshire white salt-glazed stoneware: 1720 – 1800. Hard, white fabric with distinctive 'orange peel' white salt-glaze. Tea bowls, mugs and other tablewares. 5 sherds, 55 g.

Chinese Porcelain: Hard, slightly translucent white fabric with a clear glaze, often with hand-painted polychrome decoration. Known in Europe from the 13th century, but did not become common until the 16th century (Whitehouse 1972, 63). 2 sherds, 14 g.

Creamware: c 1740-1880. A cream-coloured earthenware made from the same calcinated flint clay that produced Staffordshire white salt-glazed stonewares (Jennings 1981, 227). Creamwares were fired at different temperatures, and have a lead glaze, resulting in a rich cream colour. Vessels invariably tablewares. 13 sherds, 124 g.

English Stoneware: 1680+ White/grey stoneware with a salt glaze, usually with a brown underglaze iron wash. Made at numerous centres, such as Staffordshire, London and Nottingham, from the later 17th century onwards, in a wide range of utilitarian forms (Crossley 1990). 9 sherds, 545 g.

Miscellaneous 19th and 20th century wares. Mass-produced white earthenwares, flowerpots, etc. 36 sherds, 510 g.

The pottery occurrence by number and weight of sherds per context by fabric type is shown in Appendix 1. Each date should be regarded as a *terminus post quem*.

The range of fabrics suggest that activity at this site started at some time around the end of the 11th century, and continued unabated until the present day. All the major local medieval and post-medieval wares are present, along with regional medieval imports from the lower Thames Valley, such as London and Surrey wares. It is comparable to the range of pottery from other excavations in Newbury (eg Mephram 1997), and shows a similar chronology.

The earlier medieval assemblage is fairly fragmented, with the range of vessels comprising jars, bowls and jugs, with the first-named by far the most common. By the late medieval period, a wider range of vessels, with items such as cups begins to appear. This is typical of sites of the period in the region.

There is some residuality, with medieval wares occurring in post-medieval contexts, but generally the assemblage is well-stratified, with the pottery generally showing little evidence of redeposition.

Bibliography

Barker, D, 1999 *Information sheets for the English Heritage post-medieval pottery training days, March 1999*

Crossley, D, 1990 *Post-Medieval Archaeology in Britain* Leicester University Press

Gaimster, D, 1997 *German Stoneware* British Museum Publications

Jennings, S, 1981 *Eighteen Centuries of Pottery from Norwich* E Ang Archaeol **13**

McCarthy, MR and Brooks, CM, 1988 *Medieval Pottery in Britain AD900-1600* Leicester University Press

Mellor, M, 1994 Oxford Pottery: A Synthesis of middle and late Saxon, medieval and early post-medieval pottery in the Oxford Region *Oxoniensia* **59**, 17-217

Mephram, 1997 Pottery in Vince AG, Lobb, SJ, Richards JC and Mephram, L *Excavations in Newbury, Berkshire, 1979 – 1990* Wessex Archaeol Rep **13**, 45-67

Orton, C, 1988 Post-Roman Pottery in P Hinton (ed.) *Excavations in Southwark 1973-76 and Lambeth 1973-79*. MoLAS and DGLA Joint Publication **3**, 295-364

Pearce, JE, Vince, AG and Jenner, MA, 1985A *Dated Type-Series of London Medieval Pottery Part 2: London-type Ware* LAMAS Special Paper **6**

Pearce, J and Vince, A, 1988A *Dated Type-Series of London Medieval Pottery. Part 4: Surrey Whitewares* London and Middlesex Archaeol Soc Special Paper **10**

Pearce, J, 1992 *Border Wares* HMSO

Whitehouse, D, 1972 Chinese Porcelain in Medieval Europe *Medieval Archaeology* **16**, 63-78

Pottery occurrence by number and weight (in g) of sherds per context by fabric type

Cntxt	Newb B		Newb C		Londn		Brill		Surrey		Tudor G		GStone		Cistercn		Redware		Border		TGE		Staff slip		Mangan		SWSG		Porceln		Creamw		Eng Stn		19thC		Date
	No	Wt	No	Wt	No	Wt	No	Wt	No	Wt	No	Wt	No	Wt	No	Wt	No	Wt	No	Wt	No	Wt	No	Wt	No	Wt	No	Wt	No	Wt	No	Wt	No	Wt			
101			2	21					1	3					1	6	11	239																		M16thC	
103																																		13	235	19thC	
104																			2	24																M16thC	
127			2	22			1	16																												13thC	
129	4	49	2	19																																L12thC	
134	1	16																																		L11thC	
142			3	32																																L12thC	
204														1	3	1	9																			M16thC	
206	1	56											1	11																						L15thC	
209	1	17																																		L11thC	
306	8	133	3	25					3	16																										M13thC	
307	6	95	1	38																																L12thC	
308			1	9																																L12thC	
426			1	9																																L12thC	
428	1	48																																		L11thC	
503																2	141			1	16															17thC	
512																4	153																			M16thC	
513																						1	12													M17thC	
602																																			1	48	19thC
607																																					M16thC
609	1	4	1	6									1	3	4	192																				M16thC	
610	37	373	4	66																																L12thC	
718			1	14																																L12thC	
719												1	5																							15thC?	
803																1	89																			M16thC	
804																1	18																			M16thC	
808	2	41																																		L11thC	
809	3	27																																		L11thC	
810	2	14	1	20																																L12thC	
811			1	43																																	L12thC

Cntxt	Newb B		Newb C		Londn		Brill		Surrey		Tudor G		GStone		Cistercn		Redware		Border		TGE		Staff slip		Mangan		SWSG		Porceln		Creamw		Eng Stn		19thC		Date
	No	Wt	No	Wt	No	Wt	No	Wt	No	Wt	No	Wt	No	Wt	No	Wt	No	Wt	No	Wt	No	Wt	No	Wt	No	Wt	No	Wt	No	Wt	No	Wt	No	Wt			
812	1	9																																		L11thC	
907																										1	36			3	23			3	35	19thC	
908																	15	1021								3	16	2	14	6	61					M18thC	
909																	3	304							2	105	1	3			2	23	1	103			M18thC
910													1	4			1	9																		M16thC	
915																	2	420														3	276	5	55	19thC	
916																	3	97																13	132	19thC	
918																			1	14									2	17	5	166			19thC		
1002																	1	8																1	5	19thC	
1004			1	2													1	13																		M16thC	
1005	2	38	1	8																																L12thC	
1006	12	141	10	93																																L12thC	
1010					1	5																														M12thC	
1011	1	7	1	12													1	9																		M16thC	
1012											1	9																								15thC?	
Total	83	1068	36	439	1	5	1	16	4	19	1	9	2	9	4	23	53	2722	3	38	1	16	1	12	2	105	5	55	2	14	13	124	9	545	36	510	

APPENDIX 5 CERAMIC BUILDING MATERIAL

By John Tibbles

Summary

This report represents the results of an assessment undertaken on four boxes of ceramic and other building materials from ten trenches within Newbury Parkway.

The majority of the assemblage contained examples of medieval brick and roof tile with only a small quantity of underfired material. A significant proportion of the ceramic assemblage showed typical evidence of medieval roof tile manufacture within a residual context. The bulk of the assemblage was of medieval ceramic roof tile that included pegged tiles and ridge tiles, both plain and glazed. The flat roof tile could be broken down into at least two further types (Type 1 and Type 2). The exceptionally small brick assemblage of 27 fragments contained only 6 fragments with diagnostic traits the remainder being non-diagnostic.

Introduction & Methodology

A total of 236 fragments of ceramic and stone building material weighing 19158 grams were submitted for examination. A further 3 fragments of miscellaneous materials weighing 475 gms were also submitted for examination. All the fragments were retrieved from 36 contexts and were visibly examined using a 15x-magnification lens. Information regarding the dimensions, shape and fabric of the material was recorded and catalogued accordingly. It should be noted that the diversity of size and colour within the tile caused during the manufacturing process must be taken into consideration when comparing examples within collected assemblages and local typologies. The varying sizes and colours can be attributed to the variation in the clays used, shrinkage during drying, firing within the kiln or clamp and the location of the tile within the kiln.

*The Assemblage**Table 1. Assemblage Quantification.*

Form	No. of Fragments	Weight (g)
Brick	27	2553
Flat roof tile	201	16105
Ridge tile	5	500
Stone	2	465
Miscellaneous	1	10
Totals	236 No	19158 gms

The Brick

The Assemblage

An assemblage of 27 fragments of brick, with a combined weight of 2553gms was submitted for examination. Only 22% retained diagnostic qualities of width and thickness and 18% evidence characteristic of their method of manufacture (i.e. moulding sand).

Bricks: Hand-made manufactured bricks were made by the insertion of a wad of prepared clay into bottomless moulds, moistened and often covered in sand to facilitate the removal of the formed clay. The excess clay would be struck off, the form tipped out onto a palette board and removed to a prepared area of ground until partially dried, ready for firing. Early machine manufactured bricks were formed by a hand presses which were eventually superseded by steam powered machinery.

Bricks were manufactured to the required shape as per their intended use within construction. The standard rectangular brick was for common usage, the more specialised shapes to form architectural features around arches, doors, windows and vaults.

The dimensions of bricks have been subject to periods of legislation. At York in 1505, bricks were standardised at 10" x 5" x 2 ½". Parliament decreed in 1571, that the size of a brick should be 9"x 4 ½" x 2¼", in 1725 the size should be 9" x 4 ½" x 2" and by 1777 8 ½" x 4" x 2 ½". By 1850 the size of bricks were generally 9 x 4 ½ x 3" (Dobson 1850,33) although by the turn of the 20th century this size varied slightly throughout the country (Rivington 1919).

Brick Discussion

Dating of bricks is highly contentious due to their re-use nature as a valuable building commodity. The standardisation of bricks by Parliament over the centuries helped to create a more uniform brick and better architecture.

The majority of the assemblage (67%) was from within the fills of the post-medieval pit 920, of the remainder 22% was from within the clay silt layers 103 and 104. Only six fragments of brick displayed diagnostic qualities of which only one fragment from fill of service cut 133 displayed both width and thickness. The remainder of the assemblage was all non-diagnostic. The six diagnostic fragments displayed thickness' of 63mm, 62mm, 52mm, 45mm, 35mm and 35mm respectively (2 ½", 2 ½", 2", 1¾. The fragment which displayed more than one diagnostic trait (134) showed dimensions of 108 mm by 63mm (4 ¼" x 2 ½"). Dating from thickness alone is tenuous, however, all the thickness identified were of a size contemporary with either medieval (i.e. < 2 ½") or early post-medieval manufacture (Lloyd 1925, Brunskill 1990). Two fragments from the humic clay 426 are likely to represent medieval manufacture whilst the two fragments from pit fills 915 and 916 may represent residual medieval material. Of the 27 fragments examined 6 fragments (22%) displayed mortar stains or adhesions and 5 fragments (18%) moulding sand. No evidence of burning was identified. Two fragments from the humic clay 426 displayed smoothness on one surface, possibly the result of water action. A single fragment from context 134 exhibited mortar on all faces and edges and may represent a filler or course-levelling piece.

Six different fabrics were provisionally identified (F1, F4, F5, F9, F10, F12), of which 18% represented by F1 and 4% F4, 4% F5, 59% F9, 4% F10, 11% F12. At this stage of the assessment the source of the clay has not been attempted.

The Ceramic Tile

Assemblage Description

An assemblage of 206 fragments of ceramic tile, total weight 16605 gms was recovered within which flat roof tile and ridge tiles were identified.

Roof tiles: Positions of the nibs and peg holes are usually described from the nib side of the tile, i.e. the underside as hung, not necessarily as made. Demand normally dictated the size and quality of flat roof tile which often varied until a statute was instigated in 1477 (17 Edward IV, c iv) that dictated the size. A flat tile was fixed at 10 inches by 6 inches by 5/8 inch (255 mm x 153 mm x 16mm), a ridge tile 13 inches long by 1/2 inch thick and a hip tile 10 inches in length with a convenient width and thickness (Celoria et al 1967,218). Early flat roof-tiles were suspended by projecting nibs or by peg/nails Alternately flat tiles were often secured by iron nails, as were ridge and hip tiles. Each layer of tiles overlapped the layer below and to make them weatherproof were bedded on moss. The lowest layers, and sometimes all the layers, were often pointed or rendered with mortar (Salzman, 1952. 233)

Flat Roof Tile

Two hundred fragments of flat roof tile were identified of which thirty-one fragments (15.5%) displayed means of suspension by pegholes. Thicknesses varied between 10mm - 17mm (72% fell within the range of 13mm-15mm). Thirty-one fragments (15.5%) of the assemblage were classed as non-diagnostic.

Two types of flat roof tile were identified:

Type 1

Dimensions: 270-285mm x 148-162mm x 13-15mm

Suspension: Two near circular holes 15-20mm diameter punched from the underside. Holes vary between 55-85mm apart and between 30-45mm from LHS and 20-48 from RHS

Fabrics: F1, F3, F5, F7, F10, F11, F12

Glaze: Dark red (2.5YR/3/6)

Type 2

Dimensions: ?mm x ?mm x 12-17mm

Suspension: At least one square peghole 12mm x 12mm

Fabrics: F1, F7

Table 2: Flat tile classification

Flat Tile Type	Fragments
----------------	-----------

Type 1	28
Type 2	3
Non-classified	169
Total	200

Forty fragments (20%) displayed mortar stains or adhesions and 87 fragments (43%) moulding sand and or moulding lips. A total of 11 fragments displayed glazes or glaze splashes ranging from a dark brown (2.5YR/3/3) to a dark yellow brown (10YR/4/6).

Four fragments from contexts 426, 428, 718 displayed evidence of burning and three fragments from contexts 718, 807, 916 were under-fired.

Ten different fabrics were provisionally identified (see table) of which 88 fragments (44%) represented F1 fabric.

Table 3: Fabric types x quantity

Fabric Type	Fragments
F1	88
F2	5
F3	12
F4	19
F5	5
F7	40
F8	3
F10	9
F11	18
F12	2
Total	201

Ridge Tiles

Ridge tiles are specifically made for covering a roof ridge and according to Scott's description (1964), vary in shape between half-round (a semicircle of 7 ¾" diameter), hogback (half-round tiles with a raised centre), segmental (flattened half-round tiles) and angle (sharp angle bend with flat surfaces). Ceramic ridge tiles are generally either half-round or hogback in shape. They would be held in place by mortar and/or nails and overlap the adjacent tile, although in some cases may be butted up end to end.

Five fragments of ridge tile were identified within the assemblage from five contexts (101, 103, 426, 809, 1006). Their thickness varied between 14mm-20mm. Only one fragment displayed mortar (426) and one fragment evidence of burning (809). A single fragment from 101 displayed evidence of a dark brown (7.5YR/3/4) glaze.

Three different fabrics were provisionally identified (F1, F3, F7), of which two fragments each were represented by F1 and F2 fabrics.

Ceramic Tile Discussion

The deposition of flat roof tile appears to be fairly evenly spread throughout the site with occasional small concentrations (i.e. context 426 humic clay -22 fragments and Pit fill 916-31

fragments). Although context 803 is considered to be a demolition dump only one fragment of roof tile (Type 1) was recorded from within it. None of the remaining contexts could be positively identified as demolition dumps although the majority of tile within these contexts may be considered as casual deposition. The deposition of tile within the later post-medieval pits (909, 910, 915, 916) and dumps can be considered as residual. The presence of the flat roof tile can be attributed to the dumping of the residual elements of the buildings known to have existed within close proximity

The contextual deposition of the ceramic tile assemblage is of limited interpretative value, although it does reflect a variety of forms and their use within construction. The material provides evidence for the architecture of buildings that had included flat-tiled roofs capped with ridge tiles.

The majority of the diagnostic material displaying suspension methods was of the Type 1 generally considered to be in manufacture by the 12th century in Newbury (Vince 1984). Type 2 tile, displaying square pegholes, are recorded within late 12th century contexts in East Yorkshire (Tibbles Forthcoming) and generally 13th century elsewhere. The style of two round/square suspension holes continued through to the 17th century (Lewis 1987).

A single fragment of a Type 1 tile (1002) displayed an incomplete hole during manufacture therefore only permitting mortar as a fixing agent.

Overall the assemblage was found to contain substantial residual material of medieval manufacture. The larger fragments within the modern make-up 1003 and fill of pit 1013 suggest a close proximity of primary deposition.

There is evidence for the use of clay ridge tiles in the area (Gloucester) from the 12th century (Vince 1984) and the small presence within the assemblage suggests that alternative forms of roof covering (i.e. lead, shingles stone tile and/or slate) would have been in use.

The small element of glazed tile within the assemblage showed that the majority displayed only splashes of glaze rather than fully glazed. All the tiles were identified as flat roof tile bar one from modern organic dump 101, which is a ridge tile. Only one flat roof tile, a type 1, could be classified from within pit fill 1011. Glazed flat roof tiles have been recorded within early 13th -14th century deposits in Beverley (Foreman 1996) and glazed ridge tiles from the 12th century (Tibbles & Tibbles 2004). The building, or buildings, from which the glazed tiles originated are likely to have had a ridge and gable ended roof. The presence of glazed flat roof tile and ridge tile suggest that the structure may have had glazed tiles along its eaves and or surrounding its smoke vent or 'chimney'.

The Stone

The Assemblage and Discussion

The exceptionally small stone assemblage of two fragments suggests casual deposition. The brick-shaped sandstone fragment from the clay silt layer 104 may represent a repair piece for a brick structure and may have been subjected to heat. Possible hearth or inglenook fragment.

Other Building Materials

The Mortar

The Assemblage and Discussion

Scotts dictionary of building describes "*mortar*" as a mixture of Portland cement, lime putty and sand in the proportions of 1:1:6 or 1:2:9 for the laying of bricks and stones. Until the manufacture of cement became general, lime-sand mortars were universal. The natural limes and cements that are used to build structures are produced by the natural calcination of limestone or other calcareous minerals. Materials such as limestone from which the production of limes and cements is extracted differ greatly within their composition which range from carbonate of lime (calcium carbonate) such as chalk, to stones that can contain between 10-30% clay (Rivington 1919).

Early mortars were composed of 1 part lime to 2 or 3 parts sand within which the Romans often mixed pounded tile in an attempt to render exterior walls impervious to rain. (Rivington 1919, 149.). By the medieval period lime could be purchased ready burnt or burned in kilns especially constructed in the neighbourhood. If sea or shore sand was to be mixed with the lime it was preferred to have been extracted in the winter months when rains washed out some of the salt which made it unsatisfactory for building purposes (Salzman 1952.152). Ideally mortar should not contain dirt, silt or vegetable matter (Brunskill 1990. 59-60) although within the 19th century attempts were made at matching mortar with brick colours. A black mortar was obtained by mixing 1 of lime to 3 of ash, ground clinker or black moulding sand from the foundry or blacksmiths shop. In the belief of obtaining greater strength iron filings and foundry scale was mixed with the lime. (Brunskill 1990.60).

No scientific analysis of the material has been undertaken, however all the mortar sample has been visibly examined using a 10x-magnification lens and described accordingly. The single mortar fragment was recorded within the clay silt layer 103 and identified as a fine mortar with a white lime render both reactive to Hydrochloric acid solution. The results showed that all the samples were composed of lime and sand. Without fabric analysis at this stage of the assessment it is not possible to date.

Recommendations

It is recommended therefore that during any further works the ceramic assemblage from the site is fully quantified and compared, where possible, with existing typologies. A published report on the assemblage, including any illustrations should be produced outlining its main characteristics, discussing its significance in local and regional terms. The architectural function of the materials should also be discussed, with a view to enhancing our understanding of the structure and appearance of the buildings, which existed.

The analysis of selected fabrics may be undertaken after ceramic dating has been received, to identify patterns of supply to the site and to detect the possible products that may have been manufactured on or close to the site.

Bibliography

- | | | |
|------------------------|---------------|---------------------------------------------------------------------------------------------------------------------------------------------------------------------------------------|
| Brunskill R.W | 1990 | Brick Building in Britain. London |
| Celoria F, West
H W | 1967 | <i>A Standard Specification for Tiles in 1477.</i>
Transactions and
Journal of the British Ceramic Society, 4, 1967. |
| Dobson E | 1850 | A Rudimentary Treatise on the Manufacture of Bricks
and Tiles. Part I. London. |
| Foreman M | 1996 | Further excavations at the Dominican Priory Beverley,
1986-1989, Sheffield Excavation reports 4 |
| Lewis J M | 1987 | <i>Roof Tiles: Some Observations and Questions</i> in Med
Ceramics Vol. II 1987 |
| Lloyd N | 1925 | A History of English Brickwork (reprinted 2003) |
| Rivingtons | 1919 | Series of Notes on Building Construction.Part III.
Materials. Seventh Edition, Revised (1910) |
| Salzman L.F | 1952 | Building in England down to 1540. Oxford |
| Scott J S | 1964 | A Dictionary of Building. Penguin |
| Tibbles J | (Forthcoming) | The Ceramic Building materials in <i>Excavations at
Morton Lane, Beverley</i> |
| Tibbles and
Tibbles | 2004 | <i>The Ceramic Building Material</i> in George R: An
Archaeological Excavation on Land at Barkers
Mill, Beverley, East Riding of Yorkshire. Humber
Archaeology Report No.172 |
| Vince A.G | 1984 | The Medieval Ceramic Industry of the Severn Valley.
Unpublished PhD Thesis. University of Southampton. |

(Provisional Site Fabric Descriptions)

Fabric Number	Munsell Number	Description	Brick/Tile
F1	10R/5/6	Red homogenous fabric with freq quartz <1mm and black speckles.	Brick/Tile
F2	10R/4/6	Fine red homogenous fabric with occ black speckles	Tile
F3	10R/5/8	Red fabric with occasional quartz <1mm	Tile
F4	10R/5/6	Red fabric with freq quartz < 1mm.Occ chalk <3mm	Brick/Tile
F5	7.5/5/8	Fine red fabric with occ quartz<1mm, white speckles	Brick/Tile
F6		As F1	
F7	2.5YR/5/6	Fine red fabric with black speckles	Tile
F8	10R/5/6	Red fabric with freq red pellets and quartzite<1mm	Tile
F9	10R/5/6	Fine red homogenous sandy fabric	Brick/Tile
F10	2.5YR/4/8	Red fabric with freq chalk <5mm, quartz <1mm and red pellets <1mm	Brick/Tile
F11	10R/4/8	Fine red fabric occasional under-fired clay lens	Tile
F12	2.5YR/5/8	Homogenous sandy fabric. No visible inclusions	Brick/Tile

APPENDIX 6 ANIMAL BONE

by Fay Worley

Summary

A medieval and post-medieval animal bone assemblage from this urban site in Newbury includes the remains of domestic mammals, birds and fish. The assemblage generally is suggestive of the disposal of general refuse but one context (15th century) of sheep or goat metapodials may be waste from industrial activity such as leather tanning.

Introduction

This report presents an assessment of a moderate sized archaeo-faunal assemblage excavated during an archaeological evaluation by Oxford Archaeology (OA) in Newbury. The evaluation identified medieval and later deposits overlying alluvial sediments.

The hand collected animal bone was assessed by Fay Worley at OA. All faunal material was washed and marked prior to analysis. It is stored bagged into context groups in two archive boxes (220 x 220 x 450mm).

The hand collected animal bone is recorded in a *Microsoft Access* database which can be found with the site archive.

Phasing of the site had not been completed at the time of the animal bone assessment. This report utilises provisional pottery *terminus post quem* (TPQ) spot dates.

Methodology

Faunal material was identified by comparison with textual sources (Cohen and Serjeantson 1996; Hillson 1986; 1992; Lavocat 1966; Schmid 1972) and the OA faunal reference collection. Specimens were identified as specifically as possible to element and taxon with siding information included where appropriate. Species classes of large mammal (horse, cattle and red deer sized), medium mammal (sheep/goat, pig, roe deer, large dog sized), small mammal (rabbit sized) and micofauna (vole, mouse, frog sized) were utilised where identification to more specific taxon was not possible. Sheep and goat bone was differentiated using criteria presented in Boessneck (1969), Hillson (1986, 101) and Prummel and Frisch (1986) with the class sheep/goat used where further identification was not possible.

Indicators of age-at-death such as bone fusion (following Silver 1969), mandibular tooth attrition (following Grant 1982) and general observations on size and bone porosity were noted. With the exception of the large assemblage of sheep/goat metapodia recovered from context 9718), skeletally mature elements (those for which bone fusion was complete) were measured following standard conventions (von den Driesch 1976). Where possible, sex was determined using sexually dimorphic characteristics. Any evidence of non-metric variation and pathological alteration was noted.

Evidence for post-mortem variation (butchery marks, gnawing and burning) was noted and described when present.

Fragmentation was recorded using bone zones suggested by Serjeantson (1996) and Cohen and Serjeantson (1996). Preservation was recorded using a six point graded scale based on Lyman (1996, 355).

The weight of each specimen was recorded; the weight of any specimens less than 1 g was recorded as “0 g”. Fragment counts in this report refer to refitted fragment counts.

Results

Quantity of material

A total of 352 refitted fragments of animal bone weighing 9650 g was recovered by hand collection from the 2005 excavations at Newbury Parkway (see Table 1). The assemblage was divided between 34 contexts from 10 evaluation trenches. Although phasing information was not complete at the time of the animal bone assessment, provisional spot dates *terminus post quem* (TPQ) suggest that the assemblage dates to between the medieval and post-medieval period possibly starting in the late 11th century AD. Approximately half of the assemblage dates to contexts with a TPQ spot date of late 12th century, the majority of which was identified from context (718) (see below).

Condition

The condition of the animal bone was predominantly very good (grade 1) with approximately a third of fragments graded only ‘good’ and a further 10% graded ‘fair’ due to rounded crack edges. Only a single fragment was deemed to be in poor condition.

The favourable condition of the bone fragments allowed the recognition evidence of age-at-death information (epiphyseal fusion and tooth attrition) and post-mortem modification such as butchery marks, gnawing, burning and fresh breaks. The prevalence of these features are presented in Tables 3 and 4.

164 fragments included evidence of age-at-death from epiphyseal fusion and three mandible teeth or tooth rows could be assigned to a wear stage.

24% of the assemblage as a whole exhibited butchery marks. Further consideration of their location and form has the potential to provide information on carcass division strategies and butchery technology.

Only a single fragment of bone had been burnt.

Fresh breaks were identified on fragments from eight contexts. Fresh breaks are the result post-depositional mechanical damage.

Only 2% of the total assemblage had evidence of gnawing. These bones were restricted to six contexts. All identified gnawing had been inflicted by carnivores and indicated the presence of canids on the site and that they had access to the faunal remains. Canid gnawing raises the possibility that affected bones are have been moved from their original depositional location.

Species represented

The assemblage includes domestic mammals, domestic and possibly wild birds and fish remains (see Table 5). This is unsurprising for a medieval to modern urban assemblage.

Identified mammals include cattle, horse, pig and sheep or goat with further fragments identified as large, medium and medium/large mammal. Sheep/goat is the most common taxa, largely due to the 116 fragments recovered from context (718). The presence of canids (dog or fox) in the vicinity can be inferred from gnawing on some fragments (see above).

Only four bird bones were identified; two domestic fowl, one goose or duck (wild or domestic) and an indeterminate bird element.

Fish bones were recovered from two deposits and have not been further identified at assessment stage. One (not further identifiable to species) was recovered from a post-medieval clay silt layer while the other two were from layer (204) identified as garden soil and therefore of uncertain date.

Significant deposits, pit and ditch fills

Peat/silt layer (718) TPQ late 12th century AD

Layer (718) contained 104 fragments of animal bone, the majority of which were complete sheep/goat metapodials, sometimes with fine knife cuts. This proportion of metapodials within a single context or context group is strongly suggestive of waste from industrial activity such as tanning (see Albarella 2003). Further analysis and interpretation of this assemblage has the potential to investigate whether the industry utilised sheep or goats and whether male, female, castrate or a combination of individuals were included. The minimum number of individuals can be calculated by consideration of the element representation.

Fill of pit/ditch 821 TPQ late 11th century AD

Fill (812) contained a horse axis and large mammal thoracic vertebra.

Fill of pit 825 TPQ late 12th century AD

Fill (810) contained a cattle cranium and large mammal thoracic vertebra. The condition of the vertebra suggests that it may be residual. The cattle cranium may be butchery waste or may have been placed in the pit for another function.

Fill of pit 920 TPQ mid 16th century AD

Pit 920 contained five fills with animal bone including cattle, sheep/goat, possible pig, large and medium mammal elements.

Fill of pit 1013 TPQ mid 16th century AD

Fill (1011) contained a large mammal rib, pig right mandible and sheep/goat metatarsal.

Potential

This assemblage of animal bone has the potential to inform about medieval and post-medieval animal utilisation at Newbury. The favourable preservation conditions have allowed the recognition of butchery marks which can provide information on carcass division and butchering technology. The faunal assemblage has indicated the presence of industrial activity in the vicinity, probably related to sheep or goat leather tanning, a subject of recent academic interest. Further consideration of this aspect of the faunal assemblage can illuminate aspects of the economy of the area.

Recommendations

Although the primary analysis of the majority of the hand collected assemblage is complete, context (718) and the sieved assemblage should be subject to further analysis and the entire assemblage subject to further interpretation. No further interpretation of this assemblage should be undertaken until the phasing of the site is determined.

1. Further analysis and interpretation of sheep/goat metapodials from context (718)

These elements should be measured and speciated to either sheep or goat where possible. Interpretation of this data should consider species, age and sex profiles of the assemblage. The location of the butchery marks on these bones should be examined and interpreted. The possible industrial origin of this assemblage should be considered and parallels sought from contemporary sites.

2. Full consideration of taxonomic and element data

The consideration of the taxa and elements identified in individual features within the site, in the assemblage as a whole and within different periods of occupation may highlight economic strategies and particular functional groups. The zoning system should be used to interpret minimum numbers of individuals of different taxa.

3. Age-at-death

Epiphyseal fusion and tooth eruption and wear data should be interpreted in terms of age profiles for individual species.

4. Metric data

With the exception of the sheep/goat metapodials in (718) too few bones were measurable to be able to investigate size changes over time. Measurements should be documented in the archive and used to interpret withers heights where possible. Measurements of sheep/goat metapodia should be further interpreted (see Recommendation 1 above).

5. Butchery

Butchery marks should be used to interpret carcass division patterns and butchering techniques. Any changes between the medieval and post-medieval periods should be noted.

6. Pathology

The four pathological lesions identified during assessment should be further considered and interpreted.

Method statement

All hand collected animal bone has been analysed and primary data recorded (with the exception of metapodial measurements for context (718)). The following methods should be used for the interpretation of secondary data (see Reitz and Wing 1999 for definition of primary and secondary data). The assemblage should be quantified in terms on *Minimum Number of Individuals* and species ratios of identified specimens. Age-at-death information should be interpreted following published guides such as Silver (1969) for epiphyseal fusion and tooth eruption and Grant (1982) for tooth attrition. Metric information should be analysed for information regarding sex ratios, sheep/goat differentiation and size changes through time. Where possible withers heights should be calculated. Sheep/goat metapodia should be speciated following criteria presented in Boessneck (1969) and Prummel and Frisch (1986). Bone modification including butchery mark evidence and pathological modification should be interpreted following published texts, with photographic documentation where appropriate.

Bibliography

- Albarella, U, 2003 Tawyers, tanners, horn trade and the mystery of the missing goat, in *The Environmental Archaeology of Industry* Oxford (eds P Murphy and P Wiltshire), Oxbow Books, 71-86
- Boessneck, J, 1969 Osteological differences in sheep (*Ovis aries* Linné) and goat (*Capra hircus* Linné), in *Science and archaeology*, (eds D Brothwell and E Higgs), London: Thames and Hudson, 331-358
- Cohen, A, and Serjeantson, D, 1996 *A manual for the identification of bird bones from archaeological sites* (revised edition), London: Archetype Publications Ltd
- Driesch von den, A, 1976 *A guide to the measurement of animal bones from archaeological sites*, Harvard University Peabody Museum of Archaeology and Ethnology Bulletin **1**
- Grant, A, 1982 The use of tooth wear as a guide to the age of domestic ungulates, in *Ageing and sexing animal bones from archaeological sites* (B Wilson, C Grigson and S Payne) Oxford: BAR British Series **109**, 91-108
- Hillson, S, 1986 *Teeth*, Cambridge: Cambridge University Press
- Hillson, S, 1992 *Mammal bones and teeth*, London: Institute of Archaeology, University College London
- Lavocat, R, 1966 *Faunes et Flores Préhistoriques de l'Europe Occidentale. Atlas De Préhistoire Tome II*, France: Center Nationale de la Recherche Scientifique
- Lyman, R L, 1996 *Vertebrate taphonomy*, Cambridge: Cambridge University Press
- Prummel, W, and Frisch, H-J, 1986 A guide for the distinction of species, sex and body size in bones of sheep and goat, *Journal of Archaeological Science* **13**: 567-77
- Reitz, E, and Wing, E, 1999 *Zooarchaeology* Cambridge: Cambridge University Press
- Schmid, E, 1972 *Atlas of animal bones*, London: Elsevier Publishing Company
- Serjeantson, D, 1996 The animal bones, in *Refuse and disposal at Area 16 east, Runnymede: Runnymede Bridge research excavations, Volume 2*, (eds E S Needham and T Spence), London: British Museum Press
- Silver, I, 1969 The ageing of domestic animals, in *Science and archaeology*, (eds D Brothwell and E Higgs), London: Thames and Hudson, 283-302

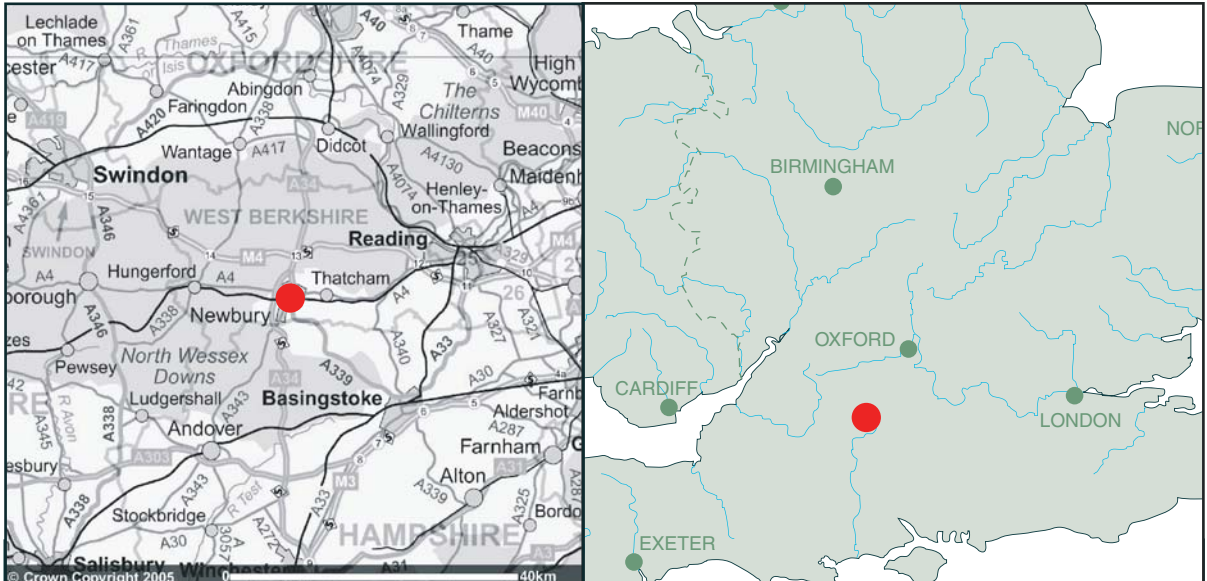

Scale 1:25,000

Reproduced from the Landranger 1:50,000 scale by permission of the Ordnance Survey on behalf of The Controller of Her Majesty's Stationery Office
 © Crown Copyright 1988. All rights reserved. Licence No. AL 100005569

Figure 1: Site location



Figure 2: Trench location plan

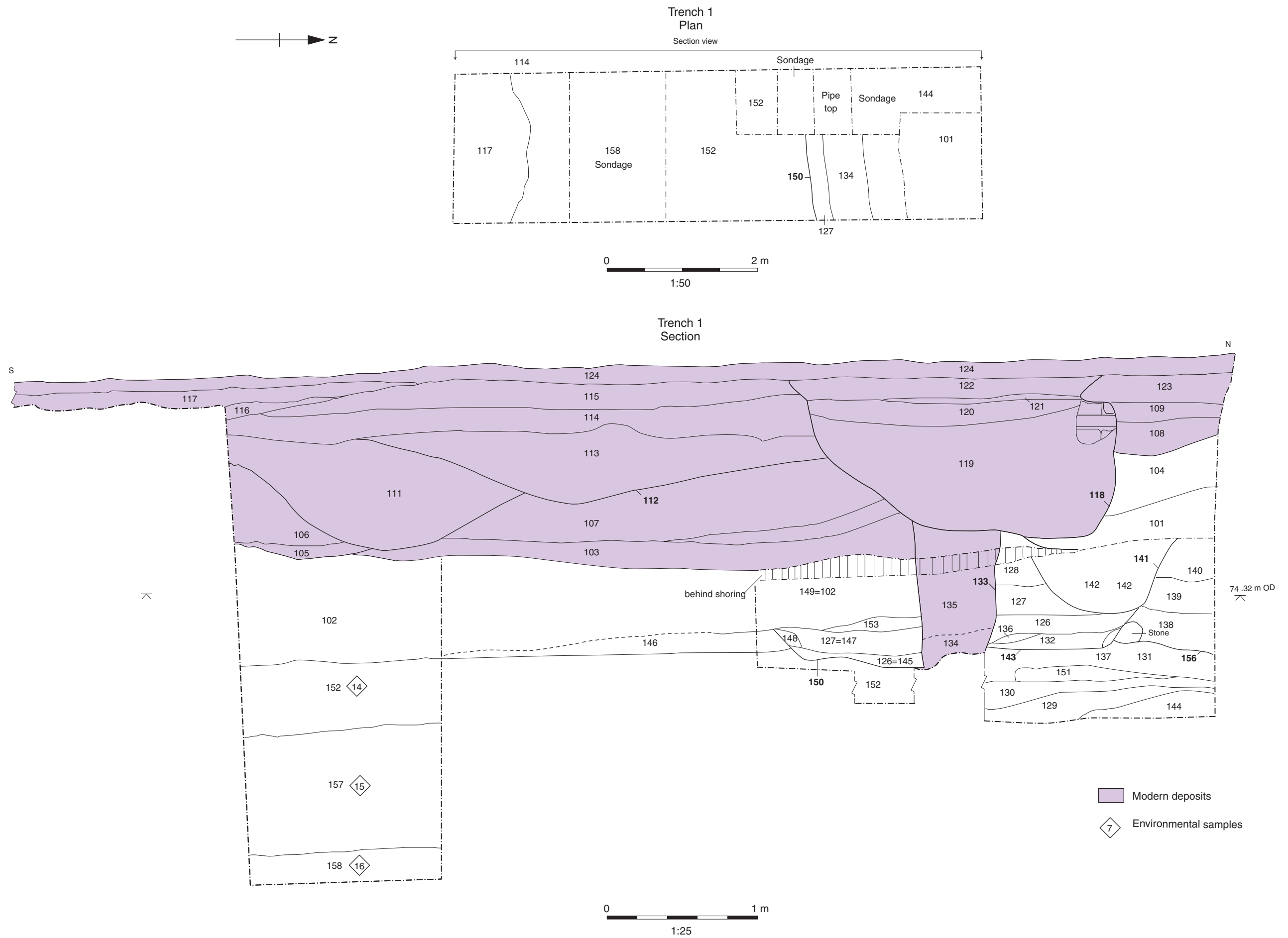

Figure 3: Trench 1, plan and section

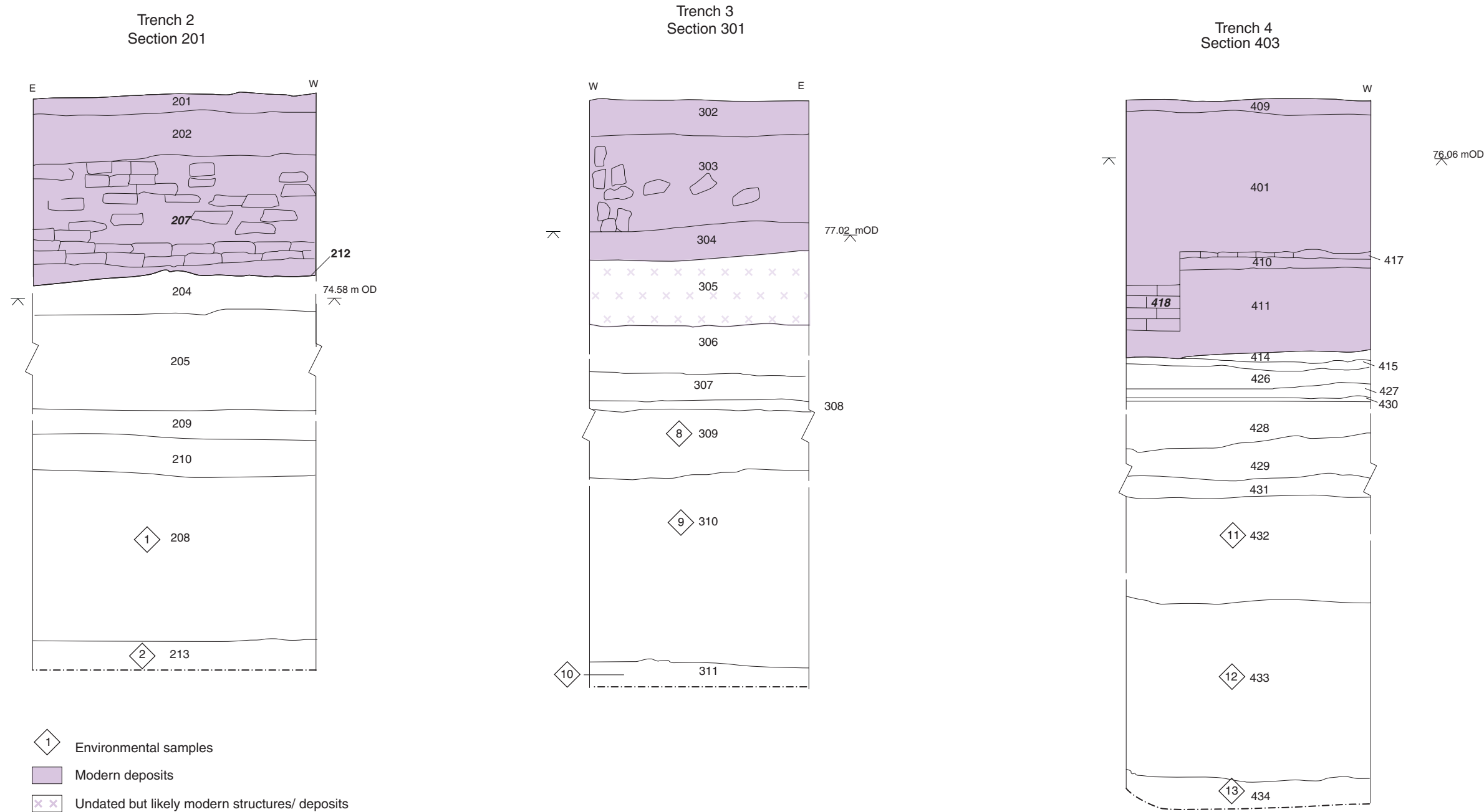
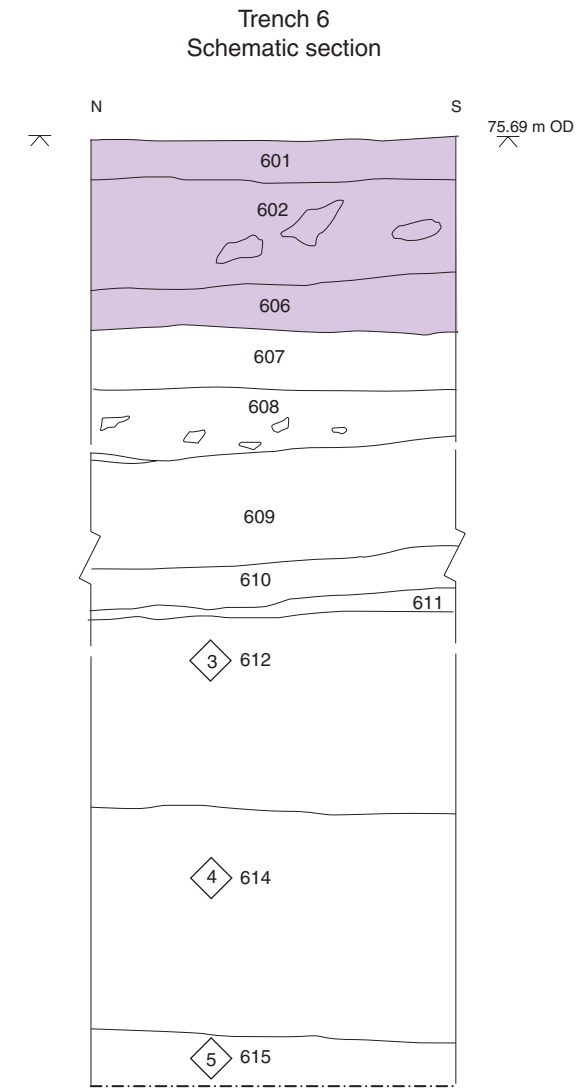
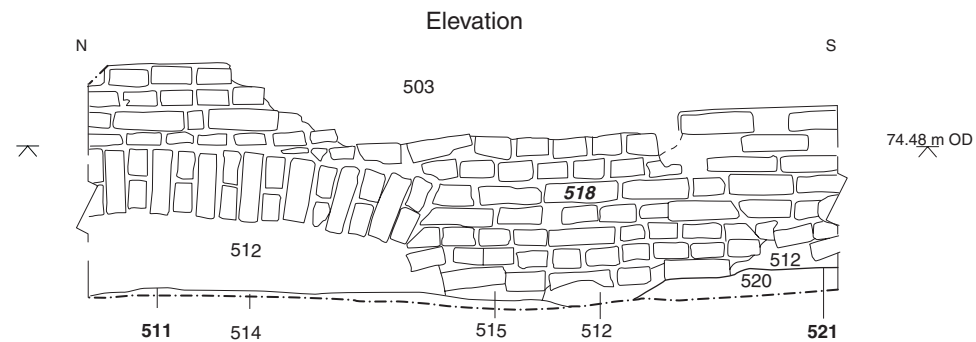
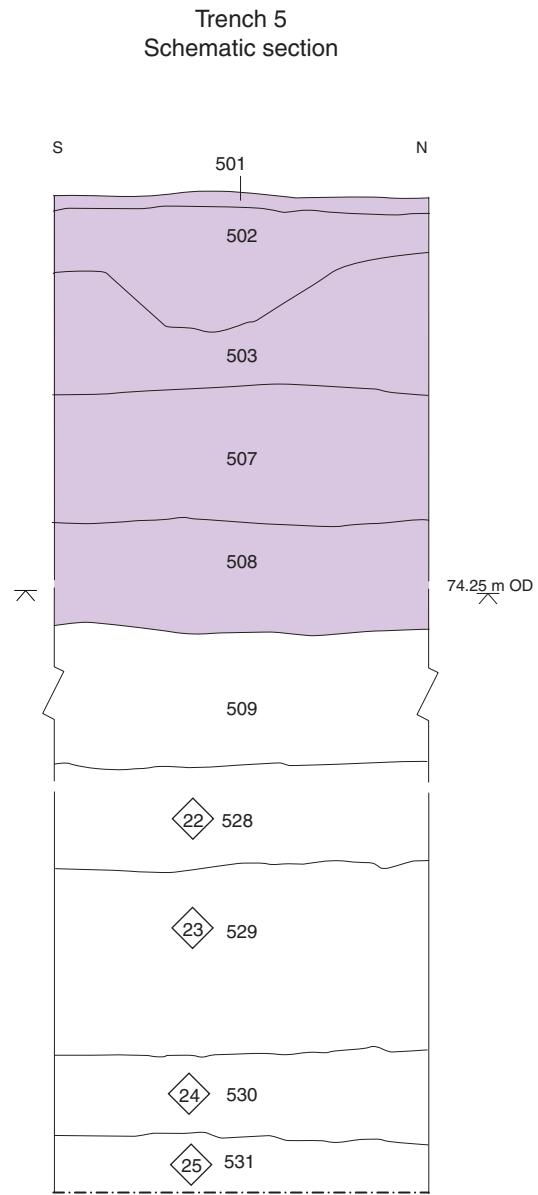
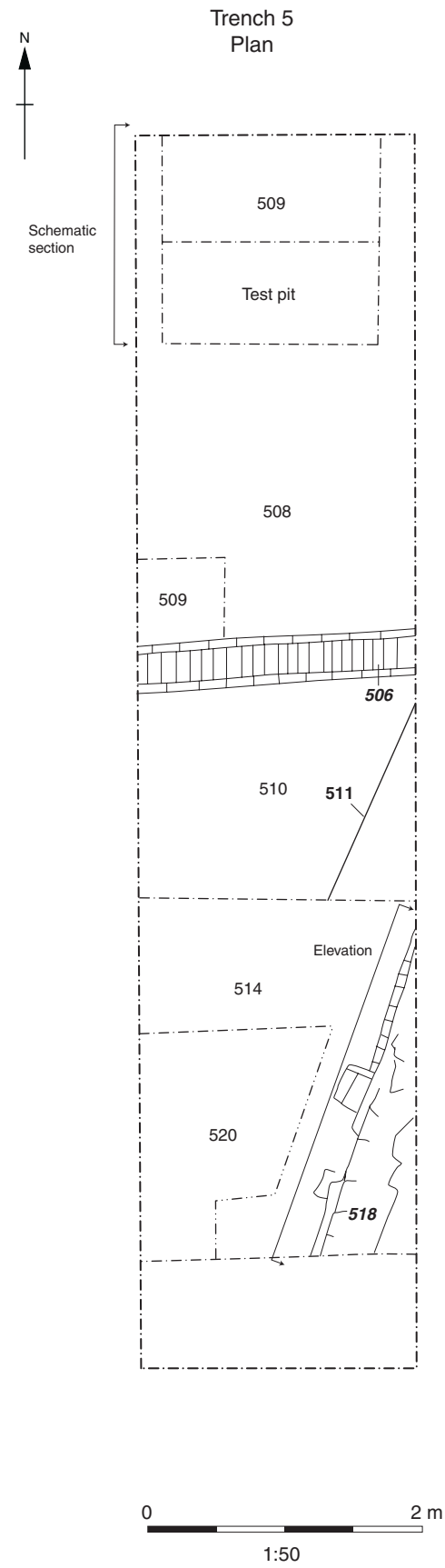

Figure 4: Trenches 2, 3 and 4, schematic sections





-  Environmental samples
-  Modern deposits

Figure 5: Trench 6, section and Trench 5, plan and section and elevation



Trench 7 Section

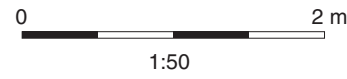
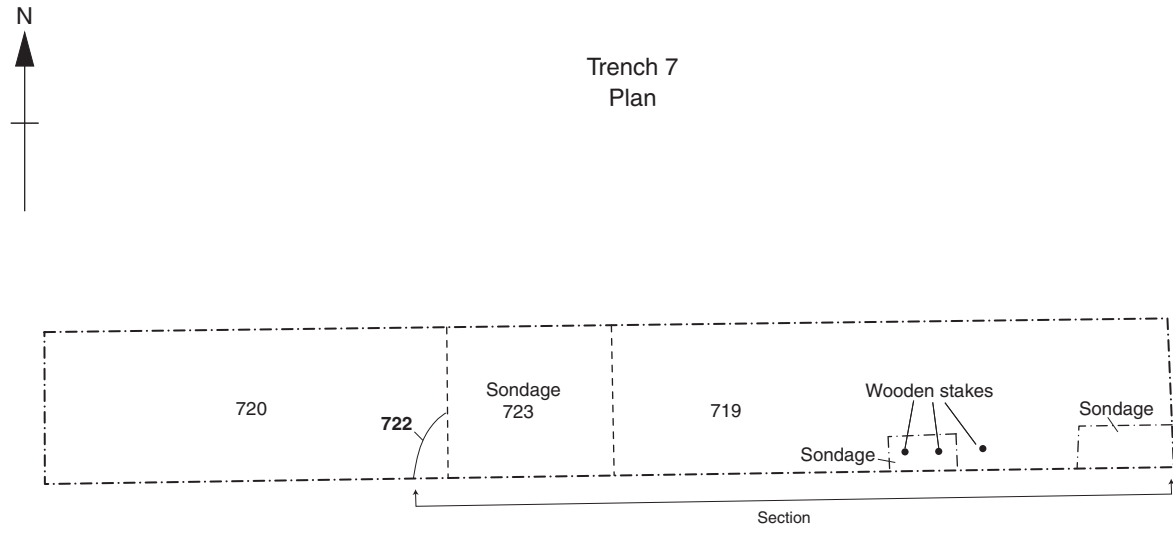
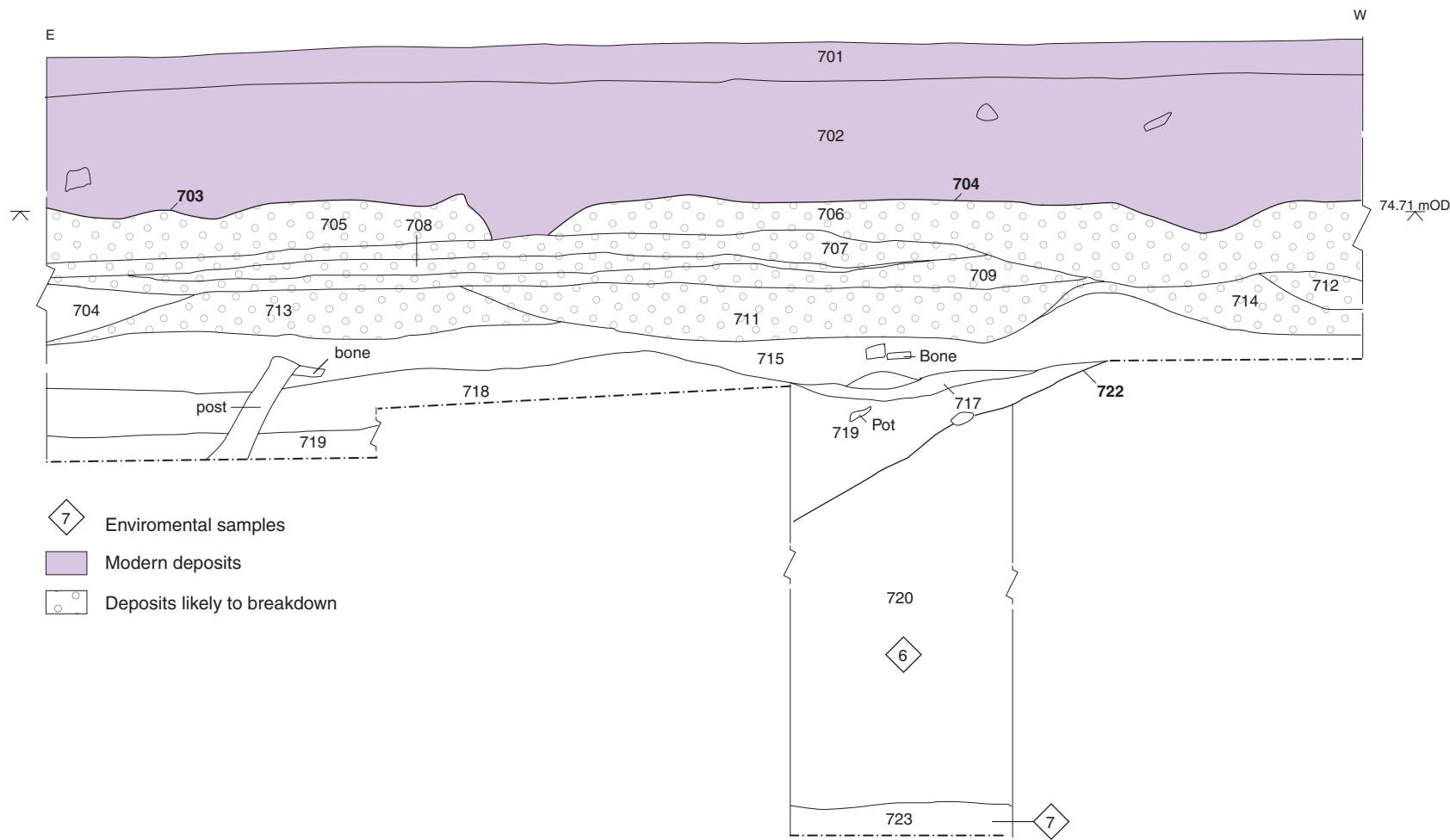

- 7 Environmental samples
- Modern deposits
- Deposits likely to breakdown



Trench 8 Sections 801 and 802

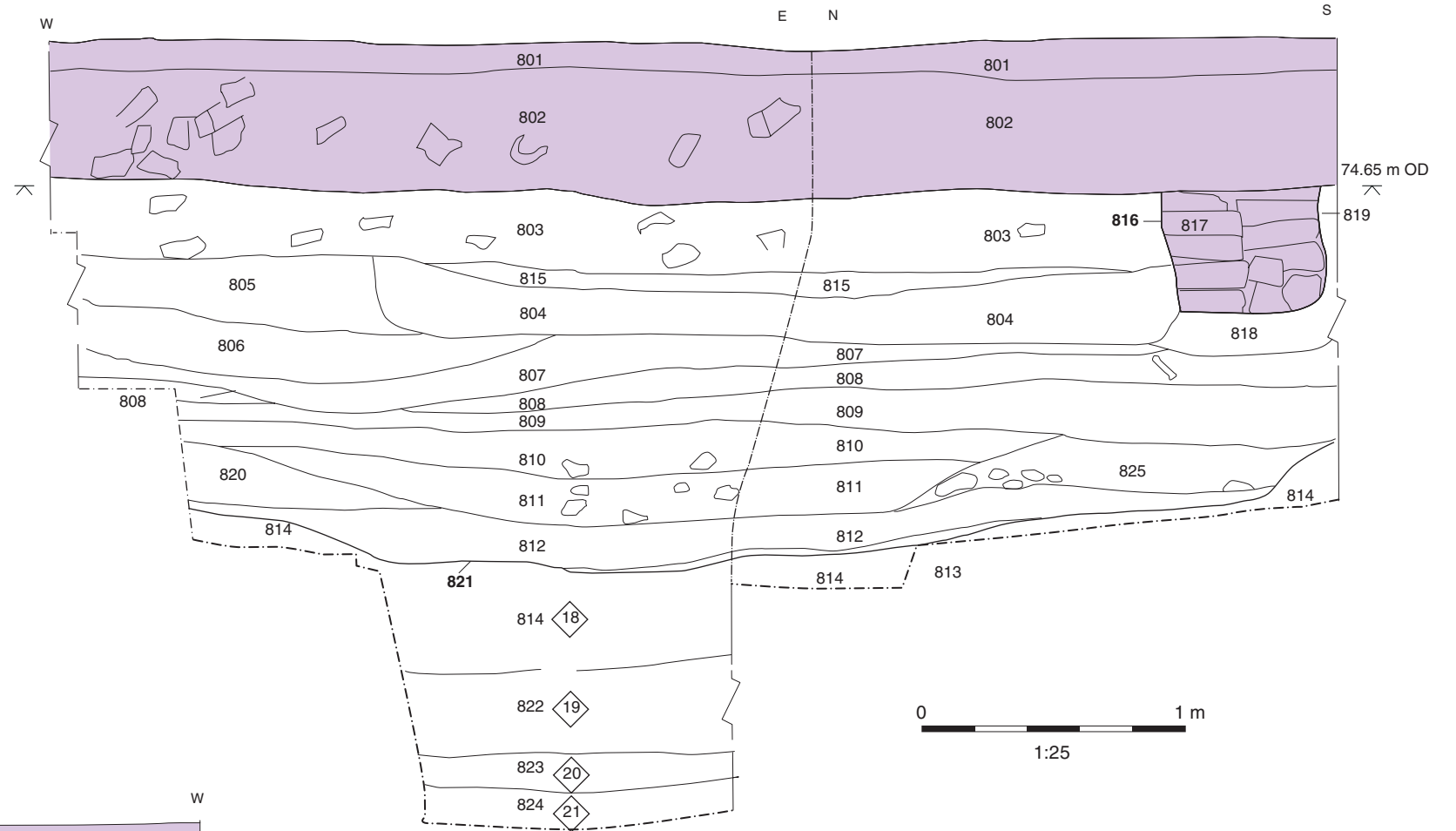

Trench 2 Plan

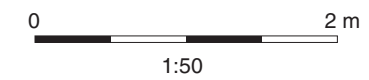
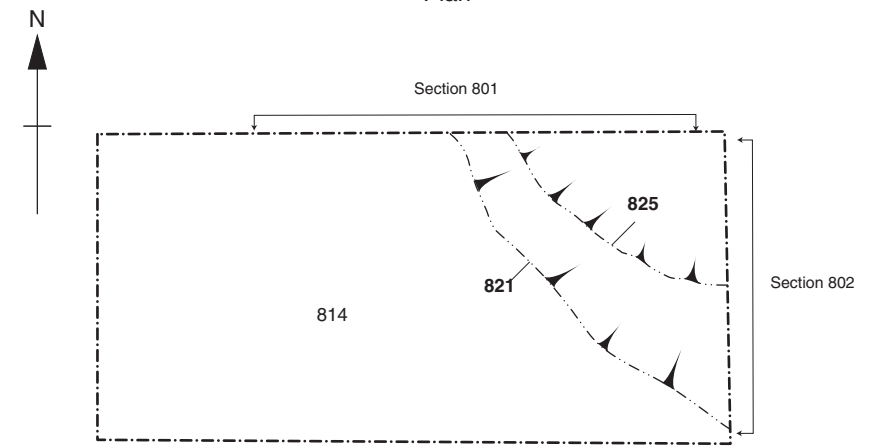
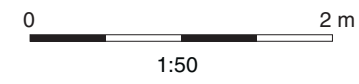
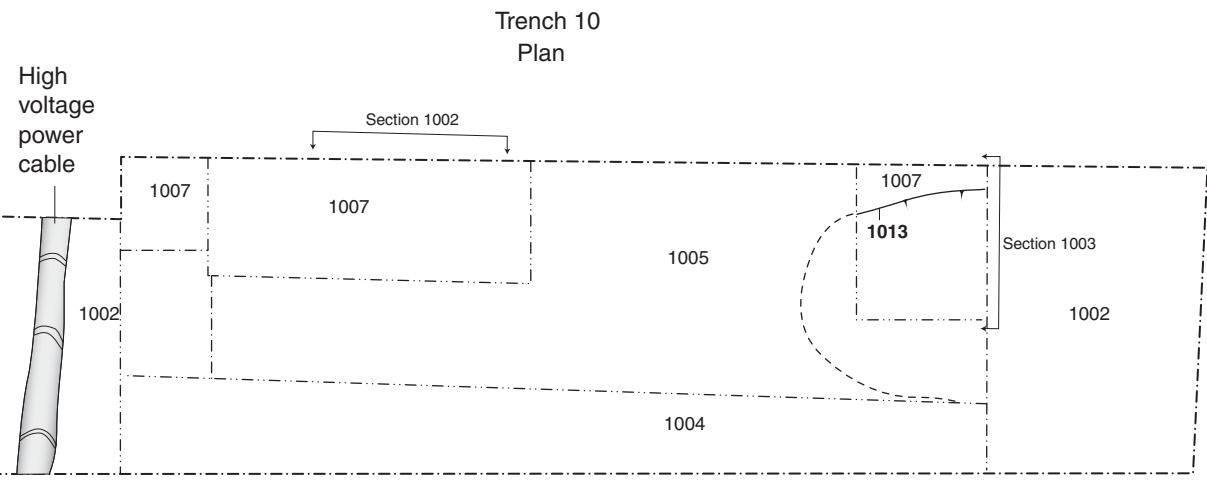
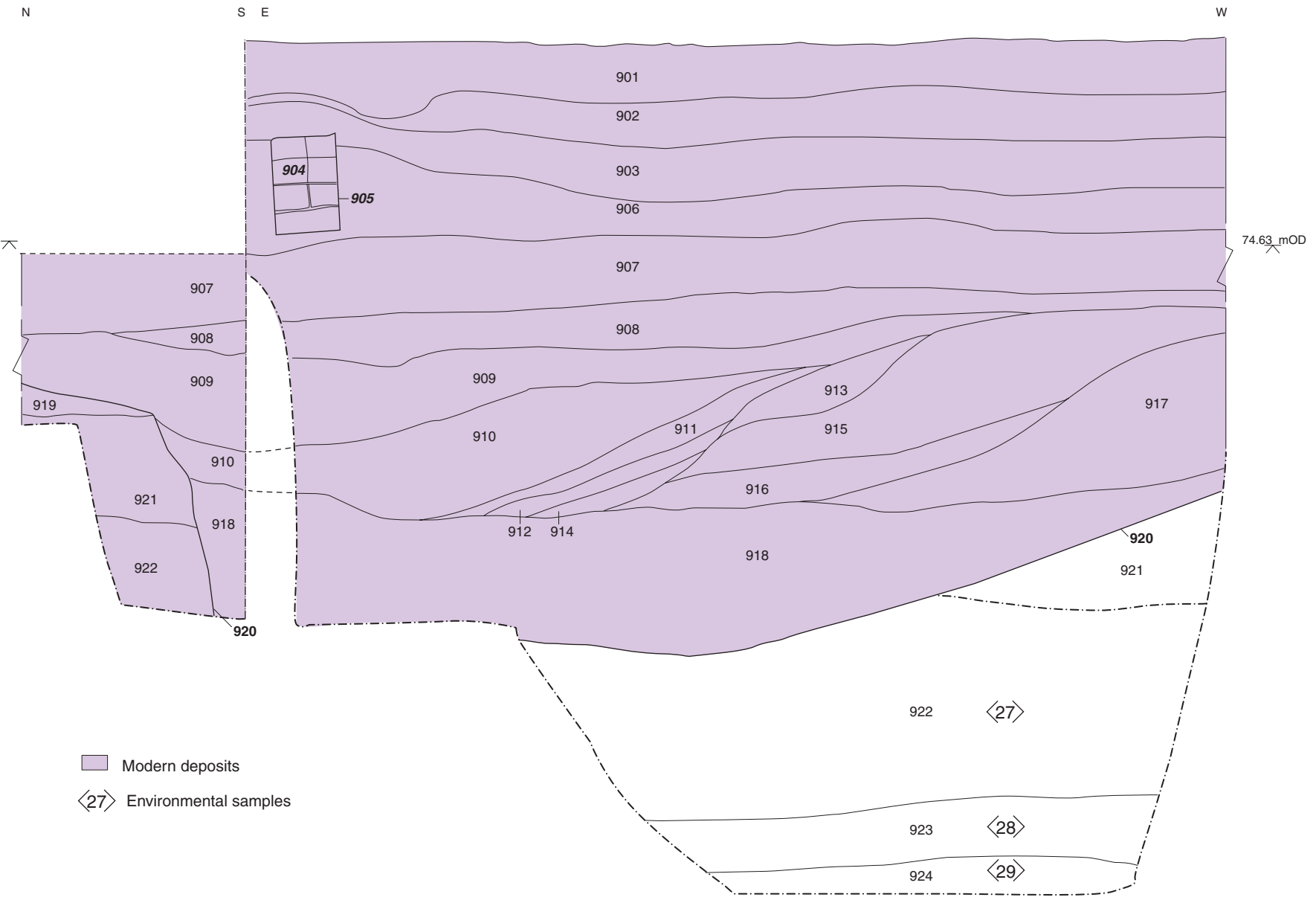

Figure 6: Trenches 7 and 8, plans and sections



Trench 9 Section 901



Modern deposits
<27> Environmental samples

Trench 10 Section 1002

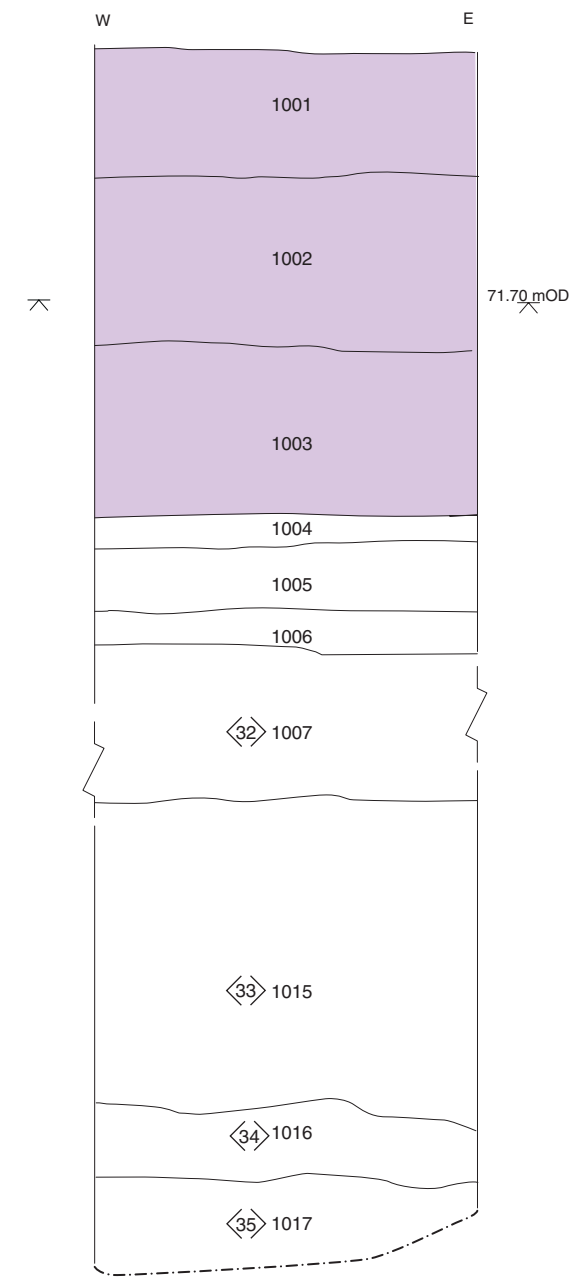

Section 1003

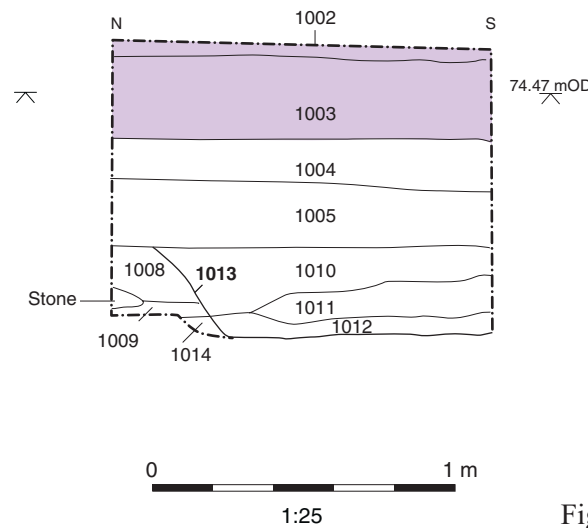

Figure 7: Trench 9, plans and sections