

LIBRARY
128

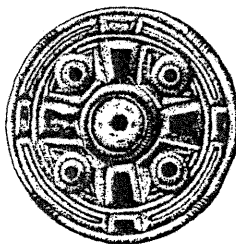

Archaeological Field Unit

**Roman-British Enclosures and Crop Processing:
A15 Werrington to Glinton Bypass
Archaeological Excavations 1996**

S.N.Kemp

June 2003

Cambridgeshire County Council

Report No. 128

Commissioned by *WS Atkins Consultants*

**Roman-British Enclosures and Crop Processing:
A15 Werrington to Glinton Bypass
Archaeological Excavations 1996**

S.N.Kemp BA MSc MIFA

June 2003

Editor : Tim Malim BA MIFA
Illustrator :Jon Cane BA and Crane Begg BSc

With Contributions by CJ Going, C. Montague, L. Higbee, D. Schlee, P. Wiltshire
and C. French



Report No. 128

©Archaeological Field Unit
Cambridgeshire County Council
Fulbourn Community Centre
Haggis Gap, Fulbourn
Cambridgeshire CB1 5HD
Tel (01223) 576201
Fax (01223) 880946

arch.field.unit@cambridgeshire.gov.uk
<http://edweb.camcnty.gov.uk/afu>

Summary

Archaeological excavations were undertaken in June and July 1996 on the site of the proposed A15 Werrington to Glinton Bypass by the Archaeological Field Unit, Cambridgeshire County Council. These excavations were funded by WS Atkins Consultants on behalf of Cambridgeshire County Council's Environment and Transportation Department. The 1996 excavations followed archaeological evaluation of the site in 1994 which revealed domestic and agricultural features dating to the Roman period. Excavations recovered further evidence of several phases of Romano British settlement and exploitation at this important Fen edge location.

The earliest cut feature on the site is a Romano-British enclosure dating to the 1st century AD. This enclosure is similar to other rural settlement sites recovered within the Lower Welland Valley area and provides further evidence for a pastoral exploitation of this area based on small, enclosed farmsteads. During the late 1st to late 2nd centuries the construction of a larger enclosure ditch along the same eastern boundary, indicates redefinition of the site but with the concentration of settlement activity remaining to the west of the excavated area. Within the excavated area there is no evidence of continuity from the Iron Age into these earliest Roman phases, however two Iron Age/Romano British brooches recovered from in the fills of later contexts are possibly indicative of the curation of artefacts and the presence of Iron Age activity within close proximity.

The late 2nd and early 3rd centuries of Romano British activity saw the imposition of a complex system of land division across the site related to Roman development of the Fens at this date and to the construction of the Carr Dyke 1.8km to the east of the Glinton site. The construction of the Carr Dyke cut off Fen edge settlements from upland resources, and the animal remains at Glinton during this phase reflects a change away from a pastoral dominated economy to an arable system. Spruce pollen recovered from this phase also indicates introduction of this tree into the Fens at this period possibly in connection with attempts to colonise the Fen edge.

Following from these Fen edge developments, the main phase of Romano-British activity at the Glinton bypass dates to the 3rd century. A stone lined well was constructed within an area of structure related gullies in the central area of the excavation, whilst further construction gullies were recovered in the north west corner of the site. A series of ponds/quarries ran down the eastern side of the site and a large midden area occupied the northern area. This midden provided evidence for large-scale secondary crop processing suggestive of arable production for exportation. This important evidence supports the idea of a hierarchy of specialised consumer/producer sites both within the Welland Valley area, which perhaps incorporated more distant sites such as Durobrivae and Stonea Camp. There is however no evidence for the importation of higher status goods onto the site, and the ceramic assemblage continues to be dominated by local domestic wares.

Cessation of settlement across the site occurred in the late 3rd century AD although midden material continued to accumulate for a short period indicating continued secondary crop processing within the vicinity prior to the complete cessation of activity. This collapse is related to changing environmental and organisational conditions within the region at the end of the 3rd century.

During the medieval period the area formed part of the open fields of Glinton and this phase is represented on the site by medieval ridge and furrow running east west across the site.

TABLE OF CONTENTS

1.	INTRODUCTION	1
2.	TOPOGRAPHY AND GEOLOGY	1
3.	ARCHAEOLOGICAL BACKGROUND	1
4.	SUMMARY OF 1995 EVALUATION	3
5.	METHODOLOGY	4
6.	RESULTS	6
	Introduction	6
	Phase I : First Century AD	7
	<i>Summary of Phase I</i>	
	Phase II Late 1st to Late 2nd Century AD	9
	<i>Phase IIa</i>	
	<i>Phase IIb</i>	
	<i>Phase IIc</i>	
	<i>Summary of Phase II</i>	
	Phase III Late second and/or Early third century	13
	<i>Summary of Phase III</i>	
	Phase IV Early to Late third century	14
	<i>Phase IVa</i>	
	<i>Phase IVb</i>	
	<i>Phase IVc</i>	
	<i>Summary of Phase IV</i>	
	Phase V Mid to Late Third century	22
	<i>Summary of Phase V</i>	
	Phase VI Medieval and Post Medieval Features	22
	<i>Summary of Phase VI</i>	
7.	THE ARTEFACTS	24
	i. The Pottery by C.J. Going	24

	ii. Metalwork and Coins by C. Montague	25
	iii. Worked Bone by L. Higbee	26
8.	THE ECOFACTS	26
	i. The Animal Bone by L. Higbee	26
	ii. Plant Remains by D. Schlee	27
	<i>Methodology</i>	
	<i>Results</i>	
	<i>Interpretation</i>	
	<i>Conclusions</i>	
	The Palynomorphs by P. Wiltshire	32
	<i>Introduction</i>	
	<i>Results</i>	
	<i>Discussion</i>	
	Micromorphology by C A I French	33
	<i>Introduction</i>	
	<i>Description</i>	
	<i>Interpretation</i>	
	<i>Conclusions</i>	
9.	DISCUSSION	35
	<i>Phases I and II First Century - Late 2nd Century AD</i>	35
	<i>Phase III Late Second and/or Early Third Century</i>	37
	<i>Phase IV Early to Late-Third Century</i>	38
	<i>Phase V Mid to Late Third Century</i>	38
10.	CONCLUSION	39
11.	ACKNOWLEDGEMENTS	42
12.	BIBLIOGRAPHY	43
	ILLUSTRATIONS	
Figure 1	Location of Investigation Area	2
Figure 2	Plan of Excavation Area	5
Figure 3	Phase Plans	8
Figure 4	Phase 1 and 2 sections	10
Figure 5	Plan and sections of Phase 1 entrance and Phase 2 re-modelling of enclosure	12
Figure 6	Plan and Section of Phase IV well	16

1. INTRODUCTION

This report presents the results of the 1996 excavations at the A15 David's Lane Werrington to Glington Bypass, Cambridgeshire (Figure 1) (TF1550 0499). These excavations were undertaken by Cambridgeshire County Council Archaeological Field Unit who were contracted by WS Atkins Consultants Ltd. on behalf of the Transportation Department of Cambridgeshire County Council. The 1996 excavations followed an archaeological evaluation of the site in 1994 and an earlier phase of geophysical survey (Reynolds 1994; Welsh 1995). The evaluation recovered both domestic and agricultural features dating to the Roman period (Welsh 1995). The 1996 excavation was designed to investigate this settlement-related activity area and to undertake preservation by record prior to road construction.

2. TOPOGRAPHY AND GEOLOGY

The 1996 excavation was located in an arable field, under a sugar beet crop, at the junction between Lincoln Road and the A15 as part of the Werrington to Glington upgrading. The main excavation comprised an area of 4,200m² (Figure 1).

The site lies on the southern side of the Lower Welland Valley; the land is generally level, and lies at approximately 10m above Ordnance Datum. The geology of the site comprises 2nd River Terrace deposits overlying Oxford Clays in an area bordered to the northwest by Lincolnshire Limestone.

3. ARCHAEOLOGICAL BACKGROUND

The Welland Valley is a rich archaeological landscape, as has been demonstrated by the work of the Welland Valley project (1971-1978) and by the Fenland Project (1976-1993) (Pryor et al 1985; Hall 1987; Simpson et al 1993). Fieldwork in the area has demonstrated a well preserved ritual landscape from the Neolithic, and attested continuity of presence into the Bronze Age.

Of particular importance, in the context of this report, is the evidence for the use of large ditched enclosures in the late Iron Age throughout the Welland Valley and East Anglia. In many cases these appear to form the basis for later Romano-British settlement patterns systems (Pryor 1985). Later, for the 2nd century, changes in both site organisation, and economic function have been documented from Fen edge sites, such as Werrington



Based upon Ordnance Survey mapping with the permission of the Controller of Her Majesty's Stationery Office Crown Copyright.
 Unauthorised reproduction infringes Crown copyright and may lead to prosecution or civil proceedings. (Cambridgeshire County Council licence No. LA 07649X 2003)

Figure 1 Location of Investigation Area.

(Mackreth 1988), and this has been linked to widespread landscape reorganisation at that period. The role played by Hadrianic colonisation of the Fens and the growth of towns with particular reference to Fen Edge and Fen settlement patterns at this period which has been discussed by Potter (1989) and Pryor et al (1985). Construction of the Car Dyke in the early 2nd century, with associated changes in access to Fenland and upland areas, and Fenland drainage is of particular importance within the Romano-British landscape.

The site at Glinton is situated 1.8km to the west of the Car Dyke within an area known to have contained a hierarchy of settlement types, including small farmsteads, villa sites and regional administrative sites such as seen at Stonea (Potter 1989). The Roman road of King Street ran to the north and west, connecting Bourne to the north and Castor to the south, whilst the town of Durobrivae, which under went considerable expansion in the 2nd century, lay only 8km to the south.



Plate 1. Photograph of the 1996 excavation Area © APS

4. SUMMARY OF 1995 EVALUATION

The area of the 1996 excavations had previously formed part of an evaluation programme along the entire length of the proposed A15 upgrading (Welsh 1995). This 1995 evaluation comprised both trenching and geophysical survey and was accompanied by desktop research. The area of the 1996 excavation was designated 'Field 2' in the 1995 evaluation and four trenches were mechanically excavated in this area at that time. Only one trench (Trench 11) contained archaeological features. These features were hand excavated in order to recover information relating to their purpose and date.

Excavation revealed a series of contemporaneous archaeological features. These comprised a steep-sided cut interpreted as a trench into which a fence was set, a gravel surface forming a strip or path, and a thick deposit of organic rich silty clay containing charred grain. In addition a possible eaves-drip gully for a small building, two larger curvilinear ditches and a series of drainage ditches were examined. The density and types of features combined with the quantity of pottery suggests the presence of a settlement in the vicinity. The excavated ceramics indicated a Roman date of between the 2nd and 4th centuries AD for this settlement, although the abraded nature of much of the assemblage caused some concern about the role of residuality within the assemblage. All of the pottery recovered was domestic in nature and was dominated by greyware and coarseware food storage, preparation, and cooking vessels. Analysis of the midden material indicated secondary crop processing activities.

In the post-medieval period much of the site was truncated by ridge and furrow cultivation.

5. RESEARCH THEMES AND METHODOLOGY

The 1996 excavations were targeted on the area of intense Roman activity recognised during evaluation trenching and geophysical survey in 1995.

General research themes which influenced the course of the investigation were:

1. examination of the Iron Age - Romano-British continuity of land organisation and settlement density within the local landscape
2. development of the Roman landscape, with particular reference to the postulated Imperial impetus behind the 2nd century Fenland/Fen Edge development
3. relationship between rural centres and urban centres in this area.

Research priorities specific to the planned excavations included:

1. investigation of the nature of the possible midden and its association with crop-processing
2. establishment of a relationship between crop-processing and associated settlement at, or in the vicinity of, the site; characterisation of the environment and agrarian economy of the local area during the Romano-British period
3. assessment of the hierarchical importance of the site in terms of the local and regional landscape.

Excavation in 1996 was targeted in one area of approximately 70m x 60m with a small extension to the north. A further 250m² of trenching was undertaken to the south, where British Gas were carrying out pipe laying works coincident with the main excavation.

Plough soil was removed by machine under archaeological supervision using a tracked 360° excavator with a toothless ditching bucket. To facilitate identification of archaeological features the entire excavation area was manually cleaned. Features were then recorded and mapped onto a base plan using a Total Station. The Total Station record was supplemented by hand-drawn plans and sections of the excavated features.

Ditch intersections were excavated to define their chronological sequences and additional lengths of ditches were excavated where necessary to provide further information on their morphology and obtain additional artefactual and ecofactual material. All beam slots, pits and postholes were excavated to a minimum of 50% and examined in section.

The 'midden area' was divided up on a 1m grid system and hand excavated in spits, within observable archaeological stratigraphic sequences. Approximately 20% of the midden was excavated. These deposits were also extensively sampled for environmental remains. In addition soil blocks were taken for micro-morphological analysis to assess the composition and micro-stratigraphy of the midden.

The well and associated construction pit was excavated by hand to depth of 1.40m with a running section. Both features were augered down to their base at 3.30m. The well construction pit was 50% excavated to a depth of 1.40m, leaving an observable section.

A sampling strategy for macro-environmental remains was undertaken on the recommendations of Duncan Schlee (Cambridgeshire County Council Archaeological Field Unit), and Dr Pete Murphy (University of East Anglia). Fifty samples were taken, with sampling concentrated on ditch fills, the midden area (F295) and well deposits. Samples for pollen analysis were taken by auger from the basal deposits of the well and by monolith from other feature fills for analysis by Pat Wiltshire of the Institute of Archaeology, London. Soil micromorphology samples were extracted from the midden by Dr. Charles French of Cambridge University.

6. RESULTS

i. Introduction

Elements of at least five phases of activity were identified during excavation and subsequent post-excavation analysis. Post-excavation analysis utilised spot dating of the ceramics to provide a chronological sequence for the site. However, this was severely hampered by the wide date range given to most of the feature assemblages resulting from the excavated assemblages being composed of locally produced 'long lived' types of domestic wares which were not susceptible to tight dating. The ubiquitous presence of residual material also hampered this chronological analysis. The extensive nature of the site, with widely spaced features often providing little stratigraphic sequence, also made interpretation of temporal sequencing problematic.

ii. Phase I: First Century AD (Figure 3)

The earliest activity on the site dates to the 1st century AD and is comprised of a presumed sub-circular enclosure ditch **M19** and a probable northward extension of that enclosure (**105/098**). In addition, a shallow east-west ditch extending across the south end of the site appears to date to this earliest phase (**196**). All these features are primarily located on the western side of the site, with many of the features extending west beyond the area of the excavation area.

Only the eastern side of enclosure ditch **M19** was recovered within the trench and, whilst the south end was well preserved, the north and parts of the north-east had been truncated by the Phase II activities, particularly by ditch **M17**. The area enclosed by ditch **M19** had an approximate internal dimension of 27m north to south. Excavated segments were **072**, **141**, **177**, **217**. The ditch itself was steep sided with a V' shaped base, with variable dimensions between 1.60m to 2.15m wide and 0.80m to 1.15m deep. The lowest fill of some segments contained evidence of a previous gravel bank (fills 177, 217). The bank was either no longer in existence or had stabilised by the time the upper fills accumulated within the Phase I ditch and the upper fills are predominantly silty sands with fewer, smaller, gravel inclusion. Although there was no evidence for an entranceway into the enclosure it must be remembered that only a part of the feature was visible within the excavation area and a significant proportion was removed by **M17**. It is possible that the feature formed a 'typical' late Iron Age/early Romano-British penannular enclosure.

A further length of ditch (**105/98**) ran southeast-northwest to the north of one of a series of later (medieval) furrows **M172** at the northwest corner of the site, and probably formed a continuation of **M19**. The dimensions and sequence of deposits within this ditch were comparable with **M19** although there was no evidence for an eroded bank. If this ditch can be seen as part of enclosure ditch **M19** then the internal dimension of that feature would be at least 33m.

About 10m to the south of **M19** was another much disturbed shallow linear **196**. This ran east-west with a width of 1.10m and a depth of 0.47m with a length of 45m within the trench. At its western end this feature extended beyond the trench edge, and was cut by **M17** (Phase IIa/b) at the junction with the trench edge. **196** also appears to curve north slightly at its west end repeating the line of **M19** whilst at its eastern end it turns northwards suggesting a larger paddock or enclosure on the eastern side of **M19**.

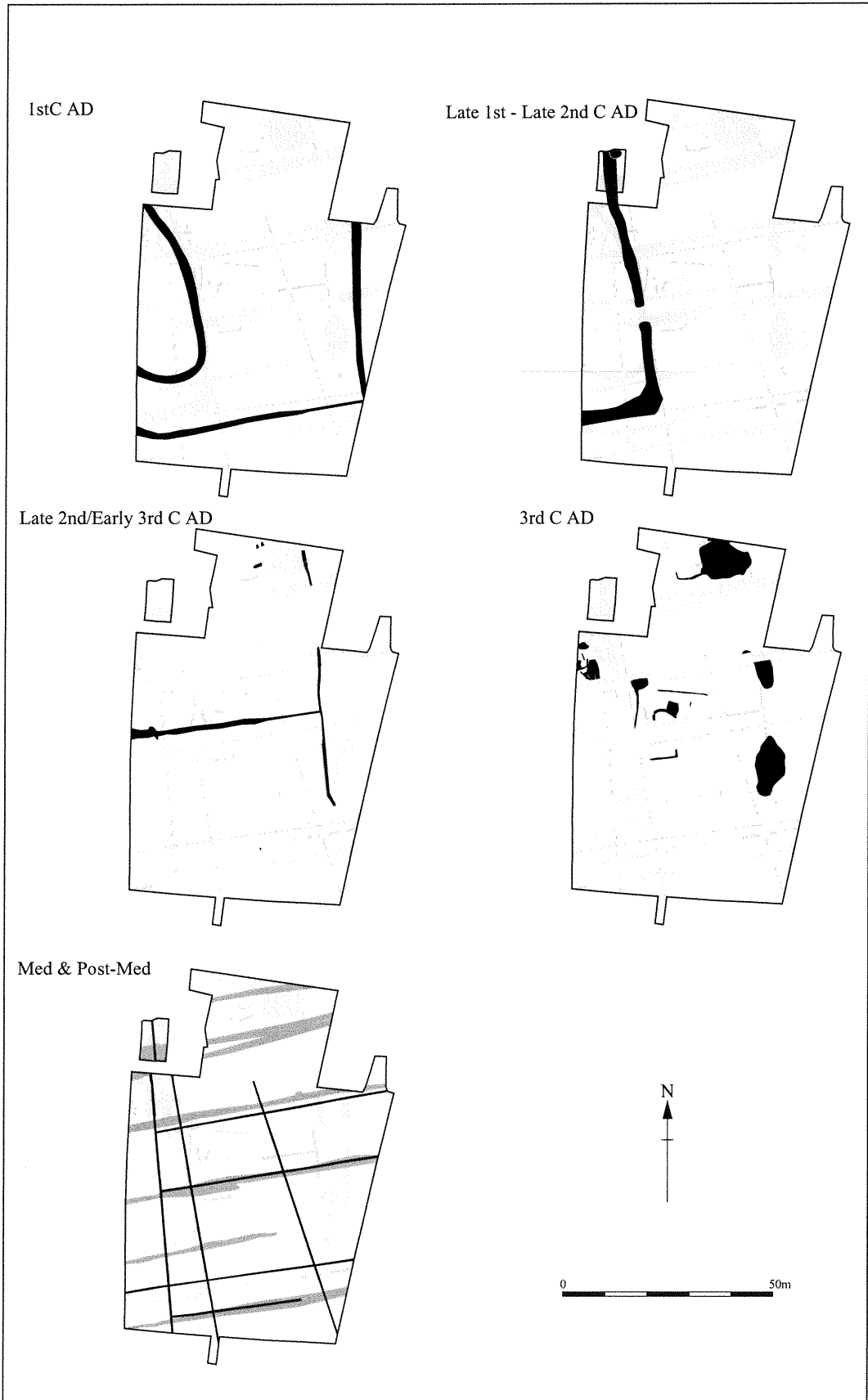

Figure 3 Phase Plans

Phase Ib

Prior to Phase II activities on the site all features associated with Phase Ia became infilled. There is no indication from these fills that there was deliberate back-filling. Fills of **M19** (067, 076, 077, 139, 140, 174, 175, 176, 220, 246) exhibited a series of basal clayey silts probably relating to the 'open' phases and water related deposits. These are followed by gravely sands with some evidence of weathering and bank collapse and then a sequence of increasingly siltier sands with fewer gravels.

Summary of Phase I

Activity during Phase I of the site is thus comprised of a penannular enclosure (**M19**) set inside of a large enclosure with little evidence of activity areas either internal or external to the enclosures. The absence of an entranceway to the **M17** enclosure within the area of excavation, and the general paucity of artefactual remains, may suggest that the main activity focus lay beyond the area of excavation during this first phase. These ditches appear to have undergone a period of infill including probable bank weathering and were largely infilled prior to Phase II.

iii. Phase II Late 1st to Late 2nd Century AD (Figure 3)

During this phase we see a re-organisation of the site, with the construction of a larger, rectangular or square enclosure cutting through and across the earlier enclosure ditch **M19**. Although the main ditch **M19** of Phase I had been infilled by Phase IIa the alignment of Phase II ditch **M17** along the course of the old ditch suggests that **M19** was still visible as an earthwork. A series of large pits along the side of **M17** appear to pre-date a re-cutting of this ditch. Three phases of this enclosure were identified. Activity is concentrated on the western side of the excavation area and there is again very little evidence for any accompanying structures or settlement.

Phase IIa

The main feature from this phase is a large enclosure ditch **M17** (excavated segments **075, 213, 280, 298**), of which the excavation recovered the southern and eastern parts (Figure 2). The maximum internal dimension of this enclosure was some 60m although no return was found at the north end where the feature ran beyond the limits of the excavation. The ditch itself, during Phase IIa, was between 1.50m and 1.94 metres in width and 0.66m to 0.80m deep. This widened to 2.80m at the termination (interpreted as an entranceway), where a depth of 0.90m was recorded. The excavated segments revealed a complex series of fills. A basal fill of sandy clay with freshwater snail shells, indicates waterlain sediments (211). Fill (246) appears to represent a weathering sandy layer, above which are predominantly sandy gravely clay fills containing ceramic and bone material (212, 245). These uppermost fills had some mixing with medieval furrow material (Figure 4).

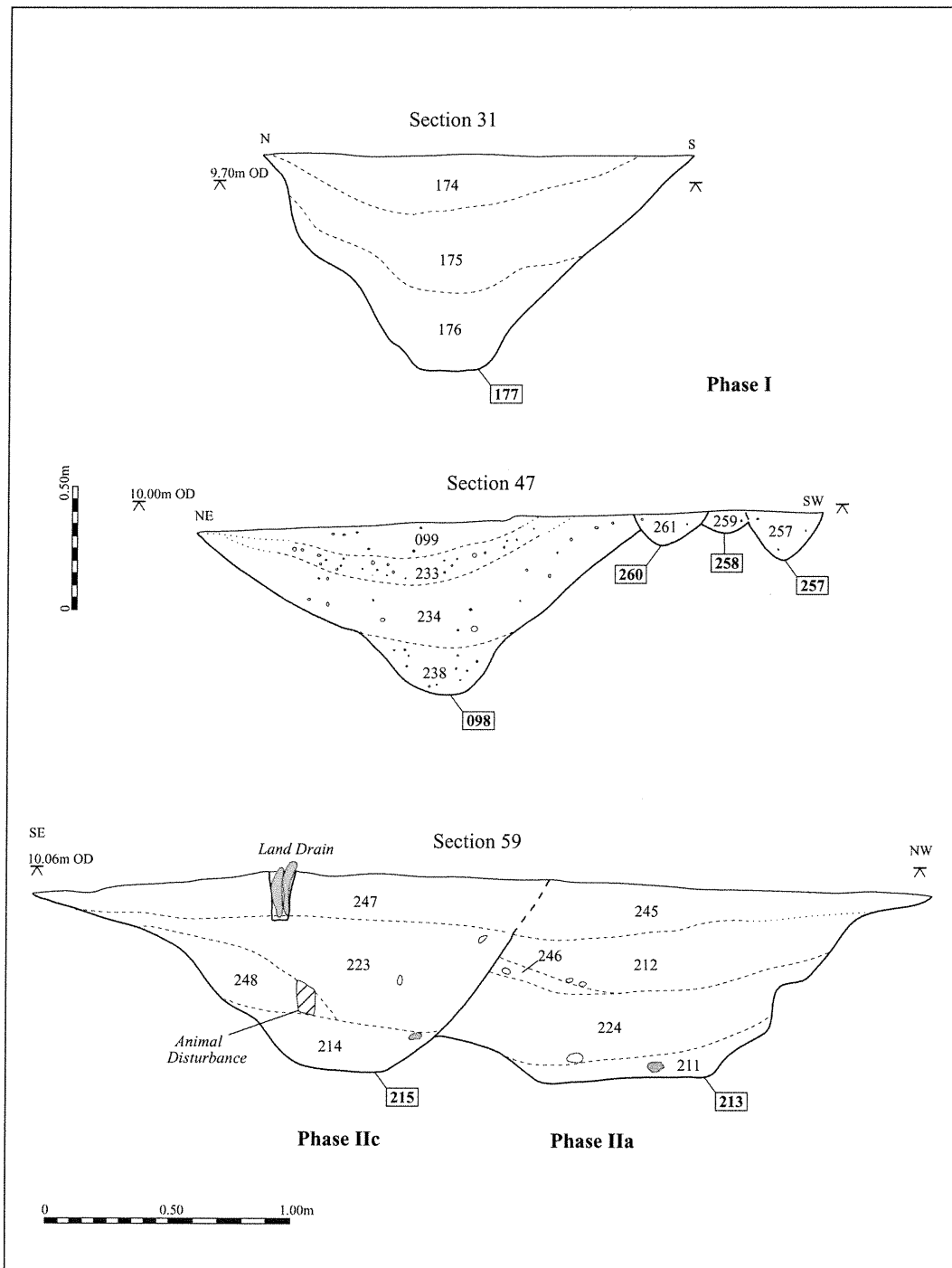

Figure 4 Phase 1 and 2 sections

An 'entrance' way was recovered on the east side of the enclosure formed by two terminations to ditch **M17** (Figures 3 and 5). The width of the entrance way was 3.70m. This was much disturbed by a later linear feature running east-west which ran immediately to the north of the entrance (**M18**) and by a medieval furrow (**M172**). There was no evidence for any posthole structures at the terminals but the feature was much disturbed in these areas. Although this enclosure extends further to the south and north than the original enclosure the eastern boundary follows the same line as **M19**. It should be noted in this context that, stratigraphically, the construction of this ditch took place after the complete infilling of the earlier enclosure, although there is some overlap in dating of the ceramic assemblages between the upper fills of **M19** and the lower fills of **M17**. Ditch **M17** also appears to have been largely infilled prior to the next phase of activity on the site.

Phase II b

During this phase a series of at least three post pits or postholes were cut into the west side of the enclosure ditch (**81**, **133**, **277**). These lay along the south side of the enclosure; in the case of **81** and **277** cutting through the fills of the previous phase of **M17**. These features varied in size from 2.00m in width to 1.00m, but with similar depths of 0.60m. The distance between pit/postholes **81** and **133** was 9m, however the fact that the pit/posthole features were recovered in each of the segments excavated might suggest that, had further segments been excavated, a more frequent spacing might have been recovered. These features appear to represent a re-instatement of the boundary line as a palisade or fence, but indicate that a ditch as such was unnecessary to the boundary function at this time.

Phase IIc

In this final episode of Phase II, the entire length of the enclosure **M17** appears to have been re-cut (excavated segments **25**, **63**, **215**, **216**, and **275**) (Figures 3 and 5). This re-cut created a substantial ditch of over 2.15m in width and 1.15m in depth. On the eastern side, external to the enclosure, the ditch was stepped, becoming steeper towards the base. This ditch appears to have had an initial infill of fine, well sorted sediments suggestive of standing water within the ditch. These may relate to the level of water table at this period. These sediments were overlain by mixed gravely fills but there was little evidence of slumping from any bank which may have been present around the enclosure. These lower fills contained a ceramic assemblage which may be dated to the 2nd century AD.

The tertiary fills of this ditch contain later organic rich material which appears to relate to the later appearance of the midden feature **295** in the northeast of the site discussed below (Phase IVb and V). The enclosure **M17** therefore appears to have been out of use but still present as a depression by the period of midden-related activity. The upper ditch fills contained mixed assemblages dating from 200AD onwards.

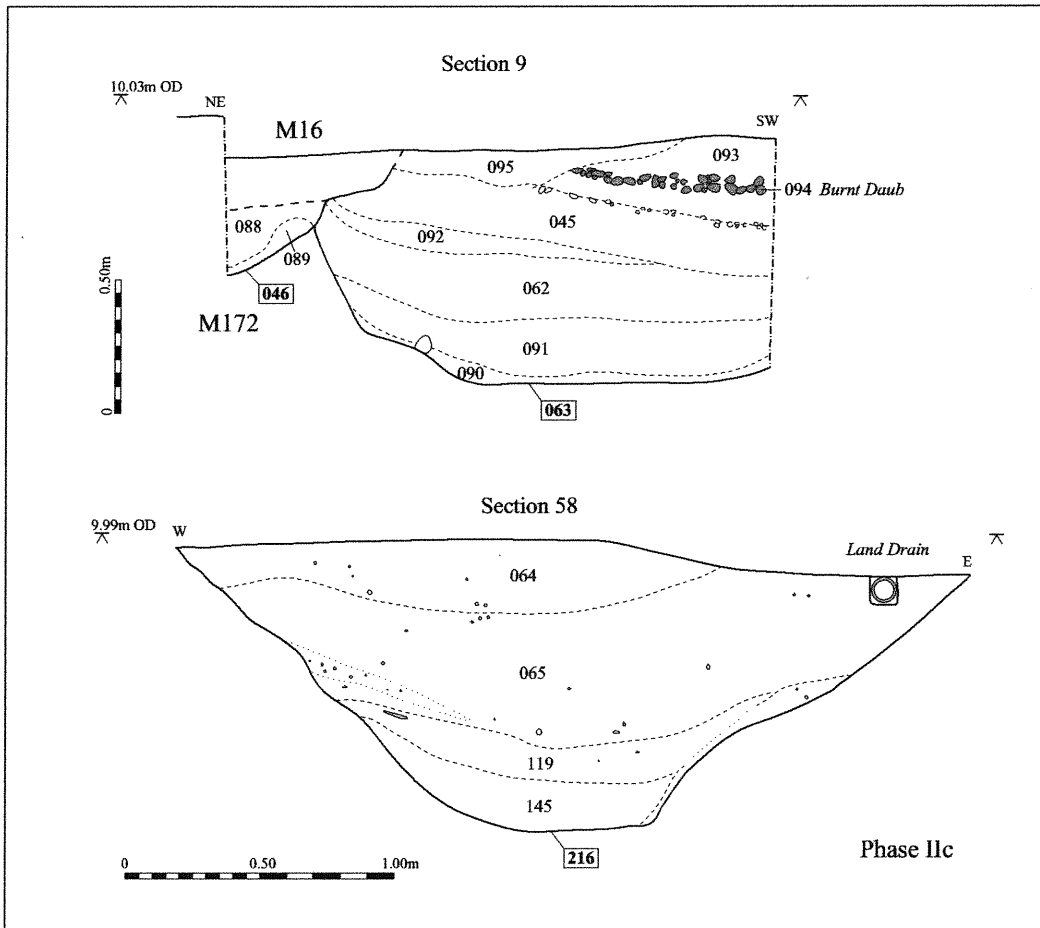
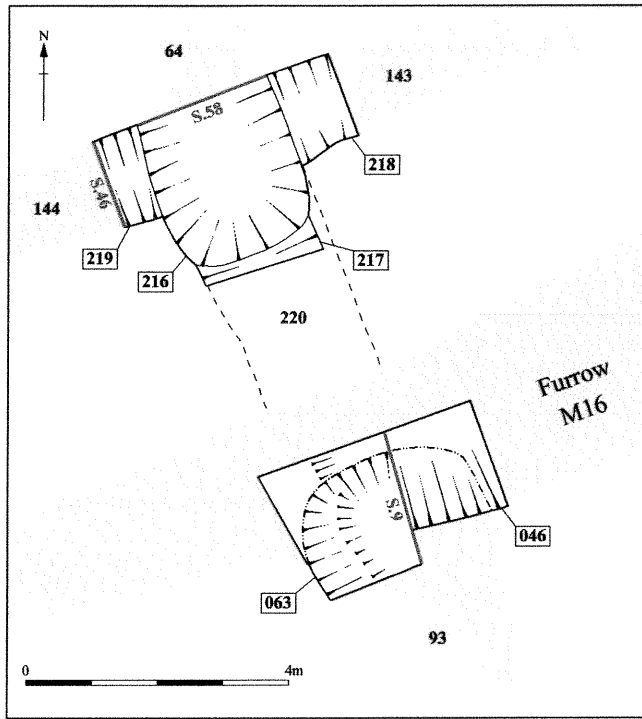

Figure 5 Plan and sections of Phase 1 entrance and Phase 2 re-modelling of enclosure

Summary of Phase II

Activity on the site during Phase II is mainly concentrated in the construction of a large enclosure ditch. The boundary is later emphasised or re-instated by the addition of a series of pits or posts subsequent to considerable infill of the original ditch cut. The ditch is then re-cut along the original alignment. Continuity of this enclosure is reflected also in continuity of the entranceway area which is respected by the post pits and the subsequent re-cutting in Phase IIc. No settlement features or activity related concentrations of artefacts were recovered which can be directly associated with this phase.

iv. Phase III Late second and/or Early third century (Figure 3)

This phase sees a substantial change in the organisation of the site, for which there is clear stratigraphic evidence, despite a confusing ceramic sequence.

M18 (218/219) (Fills 143, 144), a shallow (0.42m), wide (1.02-1.22m) linear, was recorded running east-west across the middle of the site, integrating with a north-south linear ditch **32** (fills 030, 031), forming a 'T' shape (Figure 2). Linear feature **137** (Fills 135, 136) may also be a continuation of **32** to the south of pit **149**, but appears to be on a slightly different alignment. The fills of all these features are predominantly sandy silts with a high percentage of gravels.

At the northeast end of the site the linear **241**, on the same alignment as **32**, forms a possible extension of this 'T' shaped ditch system. Although the fills 240 and 241 have a higher percentage of silts and **241** also contains some mixed midden material. This feature runs just to the east of the midden **295** and alternatively may have formed a delimiter to the area of midden activity in Phase IV. Midden material does not spread to the east of **241** until the later phases of formation when the midden is no longer contained by the feature. However, it should be noted that further to the south shallow irregular features **194** and **47/149** (Phase IVa), similar in type to the original shallow midden cut the infilled ditch system **218/219** and **32** and are therefore considered to be different phases of activity.

The 'T' shape **M18** indicates a distinct change in focus or emphasis from the ditched enclosures to the west, to site organisation and activity which spreads over the whole of the area excavated. The exact interpretation of the 'T' shape is uncertain, however it probably demarcates small field enclosures or paddocks. **218/219** cuts through fills of **M17**, but there are indications that the earlier feature was still visible as a depression at this time. It is interesting that **218/219** cuts **M17** at the terminal on the north of the entranceway, and it may be suggested that there was some continuity between these boundaries. However, **M172** has the same relationship with the terminal at the southern end of the entrance which is considered as co-incidental and related to a longer lived landscape feature.

In addition to **M18** an irregular shallow gully (**50/285**) 0.29m wide and 0.13m deep, ran for about 8m to the south of the well-pit, terminating at **M18**. The ceramic assemblage from this feature gave a very wide date range of the 1st to 4th centuries. The well pit cut this gully at least in its initial phases and it appears to be contemporary with **M18**. The feature contains a single dark yellowish soft clayey silt fill (051, 284).

Two linear features **221** and **249** were excavated on the northwest edge of midden hollow **295**, being cut by **295**. **221** was 0.59m in width and 0.26m in depth, whilst **249** approximately 0.50m to the east was 0.68m wide and 0.20m deep. Both features could only be traced for approximately 1m, being truncated by midden **295** and **M16**. East-west feature (**198**) lying on the west of **295** probably also dates to this phase. The fill of these features were dark yellowish brown to olive brown slightly clayey fine silts (222, 239, 250, 199) with a more gravelly basal material in some segments (225). These fills were cut by midden **295**.

Summary of Phase III

This phase sees dispersion of activity across the site beyond the 'limits' of the earlier enclosures, which were largely infilled by this phase. This possibly suggests a period of disuse between Phase II and Phase III. A series of narrow ditches appear to have been used to demarcate areas of the site, although the quality of the ceramic assemblage makes contemporaneity of the series of small ditches and gullies difficult to establish. It may be proposed that these represent part of a larger rectangular boundary or field system layout, which extends beyond the limits of the site. This type of linear division is common amongst Roman sites of this period, in particular within the Cambridgeshire Fen Edge region (Mackreth 1988).

In addition there appears to have been some activity in the area that was to later become the focus of the midden feature. These features may represent beam slots relating to a structure in this northeast corner of the site, possibly related to linear feature **241** or a preliminary laying out of the area for subsequent midden use.

v. Phase IV Early to Late third century

This phase sees a substantial shift in the type and spread of features across the site with slighting of the boundary ditches of Phase III and a concentration of activity in two main areas - the centre and the northeast.

Phase IVa

Two large irregular depressions or hollows, **47/149** and **194** were recorded on the east edge of the site cutting 'T' shaped feature **M18** (Phase III). The interpretation of these features is uncertain. The fill material of **47/149** suggests gradual infilling and sedimentation whilst **194** appears to have been filled in rapidly, with the uppermost fill being of the very organic rich material typical of the uppermost fill of several features

across the site (see Phase IVb). A quarry for sands and gravels, or a water collection function might be suggested for these features, the latter purpose perhaps being incidental once the pit had been created.

The fill of depression **47/149** contained very abraded, residual, ceramic material dating to the first half of the 2nd century. The dating of **194** on the basis of the ceramic assemblage was also inconclusive, being broad in date from the 2nd century to the end of the 3rd century. Both of these features were irregular, the largest measuring some 15m by 7.50m, with a maximum depth of 0.65m, whilst **194** was some 3m by 6m with a maximum depth of 0.85m.

Feature **295** (filled and overlain with midden material in Phase IVb and V), had similarities with **47/149**, being irregular in shape, although considerably larger with a maximum length of 11.50m and width of 9.10m. Feature **295** also cut **241**, a postulated extension of the 'T' ditch system described above (features **198**, **221** and **249**).

Probably during the late second or early third centuries a stone-lined well (**112**) was constructed within the western part of the site (Figures 2 and 6). The well was placed centrally within a large sub-square, vertical sided pit (**118**), which was then back-filled with stiff clay. It was only possible to hand excavate this pit to a depth of 1.40m and it was augured to its base at 3.30m. The pit measured some 3.80m east-west and, although partially truncated in plan by a medieval furrow to the north, was probably originally square. The well was centrally located within this pit. The purpose of the pit was presumably both to facilitate construction of the stone-sided well, and was in-filled with clay to provide an impermeable seal on this predominantly sandy gravel geology. It was noted that the pit and well were both sunk through the gravels to the underlying geological clays providing an impermeable seal at the base of the well.

The well was a circular structure constructed with angular fragments of oolitic limestone with the interstices were packed with clay. The stones were roughly 'coursed' and each stone was laid 'horizontally' (with the greatest dimension of each stone forming the width from the inside to the 'outside' of the well). The average size of the individual stones was some 0.20m x 0.15m x 50mm. Smaller, less 'platy' limestone fragments were used to form 'packing' in places on the outside of the stone construction. This 'external' side, which would not have been seen once the clay in-filling of the construction pit was in place, was much rougher than the inside of the well, with the stones projecting out to different lengths. The inside face was very carefully graded to form an almost perfectly circular shaft with no stones protruding (Figure 6).

During excavation it was noted that the stones on the inside face (below 9.30m OD) were water worn and were presumably smoothed by the constant movement of water levels within the well. This was not observed on the external face, even where this was below the present water table. It was also noted that, in places, there was a clay lining (173) to

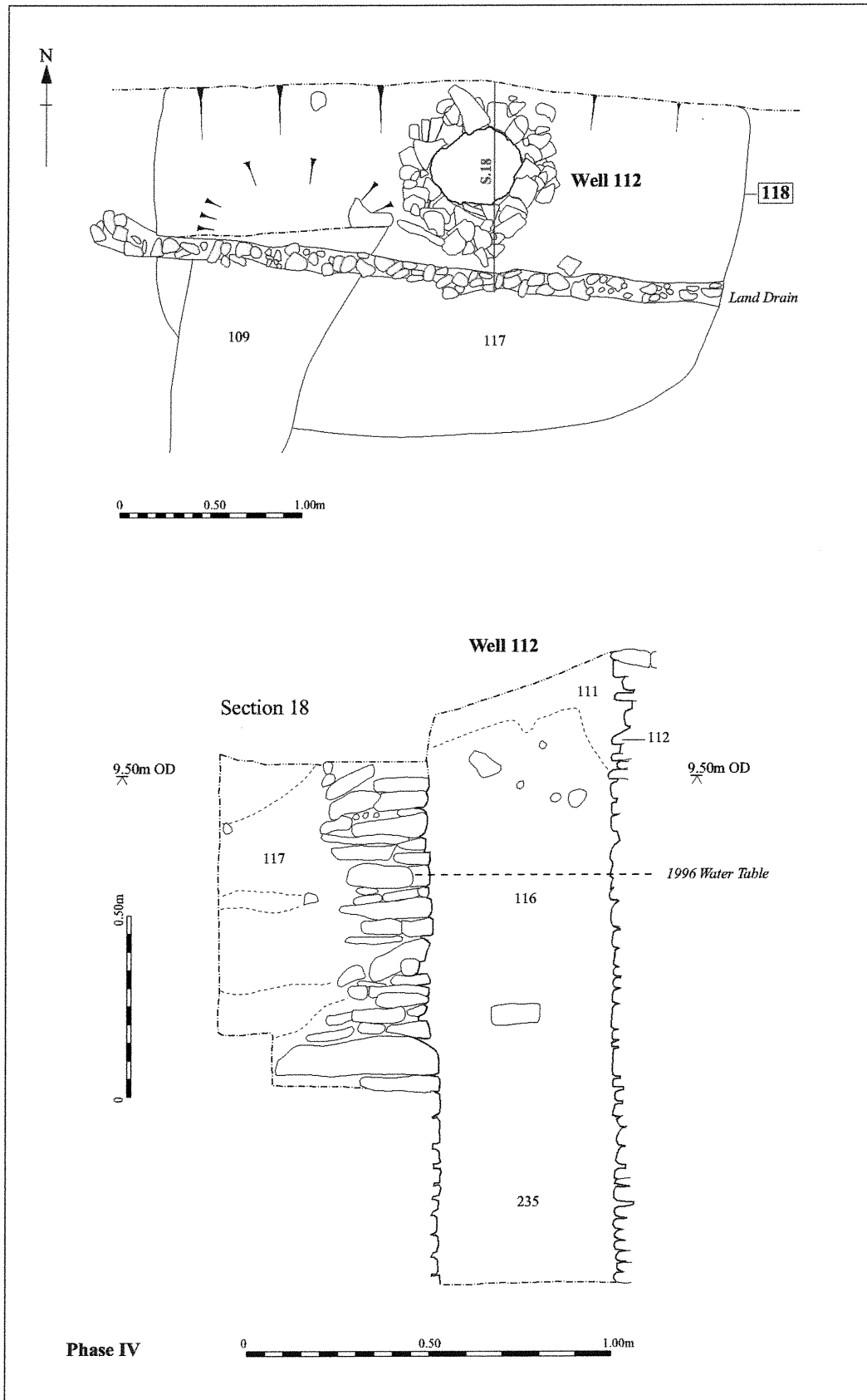

Figure 6 Plan and section of Phase IV well

the inside face which was intermittent in the surviving 'top' of the well. It was unclear whether this was constructional or a result of water movement and silting. The well was hand excavated to a depth of 1.40m, approximately 0.30m below the present water table (at the time of year the excavations took place), and then augured to a total depth of 3.30m. This basal depth was similar to the depth of the construction pit **118**.

The well contained a series of deposits the majority of which, from their relation with the probable Roman water-table height, may be judged to be post-usage. The ceramic assemblage from the well-pit (**118**) suggest a post 2nd century date with the pottery sherds small and abraded for the construction of the well. This was comparable with the basal fills of the well and gave a similar date range. The upper deposits within the well gave a 3rd century onwards date. These deposits were noted during excavation to be much higher in their organic content and were sampled for environmental analysis. Analysis of macro plant remains suggested that the final deposition and backfilling of the well took place contemporary with the spread of midden-related activity on site (Phase IVb and Phase V) at a similar time to the final backfilling of large depression **194** discussed above.

A small pit 263 placed centrally to the site may also date to this phase and may have been another attempt to dig a well. This pit was more regular in shape (sub-square) and smaller (max. diameter 2.40m and 0.15m deep) than pits **47/149**, **194** and **295**. The nature of the single, sandy silty, homogenous fill (262) appeared to indicate that the feature was not open for a long period. This feature lay about 6m to the southeast of the well pit **118** but is similar in diameter and shape, although it did not continue to the depth of the well-pit. This feature is cut by curvilinear gully **266**. The ceramic assemblage from feature **263** was not amenable to precise dating - giving a date range of 1st to 4th centuries.

Phase IVb

This phase of possible structural features may be assumed to be contemporary with the use of the well and possibly with the build up of a secondary soil horizon within the shallow feature **295**.

Seven metres to the southeast of the well two curvilinear 'gullies' **266** and **287** were excavated. Again, the abraded and limited nature of the ceramic assemblage prevents firm dating, but stratigraphically these features would appear to be approximately contemporary with the use of the well and postdate **263** which was described above as an abandoned attempt to create a well pit. The gullies were 'u' shaped in section with a maximum depth of 0.50m and a width of 1.1m.

To the south of these curvilinears was a shallow (0.25m) 'L' shaped beam slot/gully **M29** (**204**, **208**, **210**, **229**, **232**). This 0.50m wide gully, runs for 6.5m east-west about 8m to the south of **287**, and turned at the east end to run north for 1.10m, before being truncated by medieval furrow **M172**. It was not traced to the north of this furrow. Five segments

were excavated through this feature (**204, 208, 210, 229, 232**) producing consistent fills of silty sands.

Four metres to the north of the curvilinears was a small gully or beam slot **289**. This slot ran east-west for about 12.5m, and was 0.15m deep and 0.27m wide. It may be related to uncertain feature 271 of similar dimensions running north-south within the same area. All of the above features in Phase IVb contained similar brownish yellow, sandy silty, fills. Just to the east edge of enclosure ditch **M19** was a possible beam slot **273**. This butt-ended linear feature was 0.60m wide and 0.20m deep and ran for a length of 4.80m.

A further 'L' shaped gully or beam slot **M293 (201, 226, 236, 281)** next to the midden appears to have also been dug at this phase. The gully was infilled during the period of midden activity (Phase V) as the upper fills of this gully contained later ceramic material. It is possible that this gully originally formed a boundary or barrier/screen to the midden or activities around the midden. Such a screen could have been removed at a later date as the midden expanded. As recovered, the gully extended up to the shallow cut **295** but was overlain by upper midden material which extended beyond that cut.

Taken together, and although on differing alignments, this series of small gullies and beam slots and the curvilinear features appears to indicate a concentration of activity within the central area and the northeastern and northwestern corners of the site.

At the extreme northwest end of the site was a series of intercutting small curvilinear gully (**82, 84, 86, 100, 102**). These features only survived to average depths of 0.10m with widths of 0.21m. There is some uncertainty about the exact date and function of these features, which produced very few finds, although, feature **82** clearly cut through the infilled ditch **105** (Phase I).

Within the area of feature **295** micromorphological analysis of samples taken through the lower deposits suggest the build up of a secondary buried soil within this feature prior to the deposition of the midden material in subsequent phases (French, see below). Only a thin remnant of this re-worked and re-stabilised material survived, but where present it was indicative of a poorly developed brown-earth typical of terrace gravels. This may indicate a long period of standstill between Phase IVa and IVc at least in this area of the site. This buried soil was not recovered from similar features **149** and **194**. It is suspected that they function in relation to the complex of features developing around the well.

Phase IVc

It is during this phase that we first see the appearance of midden activity in the far north of the site followed, in Phase V, by the spread and accumulation of midden-type material in the upper fills of some of the ditches and the well. Analysis of this midden material indicates that it is of a similar type and date to that of the midden recorded by Welsh in 1995.

The midden spread over an area of some 11.50m by 9.10m with a depth of 0.77m (Figure 7). The main area of midden material appears to have accumulated within a large, irregular, depression **295**. The midden material overlay the secondary buried soil discussed above (Phase IVb). The midden was excavated stratigraphically, within 1m grid squares, and was extensively sampled for artefactual, environmental and micromorphological analysis. During excavation several different deposits were noted within the midden, including the buried soil deposit; these generally becoming more organic towards the surviving upper surface which effectively formed the 'B' horizon of the current ploughsoil. Results of the environmental and micromorphological sampling are discussed in detail below.

The midden deposit was sampled for macro and micro-ecofacts at various points, with the aim of recovering any variation in the environmental assemblages across its horizontal extent. Analysis of environmental assemblages from these different samples from the midden indicated a relative overall uniformity. This may either suggest uniformity in crop processing type over the period of time of the midden accumulation/deposition, or that the midden itself was formed from a homogenous source material. Secondary processing and probable cultivation of Spelt wheat was indicated as the main site activity at this phase because of the quantity of Spelt grains and chaff contained in the extensive spreads of midden material. There were also small amounts of barley, emmer and oats which are likely to be crop contaminants.

Micromorphological analysis was carried out on two samples from the midden and some variation was apparent between the two samples. Profile 2 was relatively homogenous and suggested a former organic 'A' horizon which had repeatedly been subject to the inclusion of organic 'midden' material, and homogenised by much bioturbation and oxidisation.

Profile 1 appeared to have been subjected to considerably less bioturbation, and exhibited several discrete episodes of deposition of midden and soil material, developed over a reworked brown soil with a re-stabilised 'B' horizon. Within these discrete episodes was evidence for a 'standstill' period during which the midden may have become grassed over and formed a temporarily stable surface. This suggested that the midden may itself have been 'contained' by some sort of barrier within the corner of a field or garden plot. This confirms observations made during the excavation regarding the possible role of gully **293** to the south-west of the midden. Welsh (1995) also recorded a post foundation trench forming a possible fence to one side of the midden recovered during his excavations.

Summary of Phase IV

In this phase linear features **M18, 199, 221, 241, and 249** are all truncated by a series of shallow pit/quarry features which appear to date to the first stage of Phase IV. The gully/ditches may have served to demarcate areas subsequently respected by the pits/quarries, which perhaps represents boundaries or 'screens' to these working areas.

This is particularly the case for the features concentrated within the area of F295 (midden).

During Phase IVa a stone lined well was constructed within the central area approximately 6.5m to the north of curvilinear feature **287/266**. Gully/beam slot **289** may relate to this feature as may other beam slots, gullies and curvilinear features which, although slightly later in date probably originate in a period when the well was still in use. This series of beam slots and gullies are concentrated in the central and north-west corner of the site. A further 'L' shape gully **M293**, similar in form to **M29** in the centre, is located directly to the west of the midden feature.

Pollen analysis of samples taken from close to the base of the well indicate that during Phase IVa the area was dominated by weedy grassland with rough, open soils. There were no cereal pollen but some weeds indicative of enriched arable (see below report by Schlee). Burnt wood elements suggest the presence of oak, elder and spruce. The find of large quantities of spruce pollen at Glington is of considerable importance as it had been supposed that the rare finds of spruce at other sites resulted from small scale or decorative planting.

Phase IVb is represented by a standstill phase within the north area of the site where there appears to have been a build up of secondary buried soil within the hollow of feature **295**.

Activity in Phase IVc is primarily focused on the deposition of midden material within the area of **295** at the far north end of the site. At least in its initial phases this midden activity appears to have been restricted within an area delineated by boundaries created by earthcut features and/or upstanding barriers prior to more widespread distribution of midden type material across adjacent features i.e. between Phase IV and Phase V.

A considerable amount of pottery was recovered from the upper midden deposits, particularly in comparison to that recovered across the rest of the site. This may partly reflected the high degree of sampling undertaken within the midden area. The deposits within **295** were divided into 4 units with the date range for the assemblage in upper unit, level 'a', concentrating on the 3rd century, whilst the single Samian fragment in level 'b' gives a mid first to 2nd century date. Within the lower levels of the feature very little ceramic material was recovered.

The absence of smaller fragments of bone and pottery combined with the results of both the environmental and the micromorphological analysis indicate that the upper deposits of the midden largely comprised of specialised secondary crop processing debris. This is also reflected in the pollen analysis which records the presence of cereal-type pollen which indicate that cereals were grown or processed close to the well.

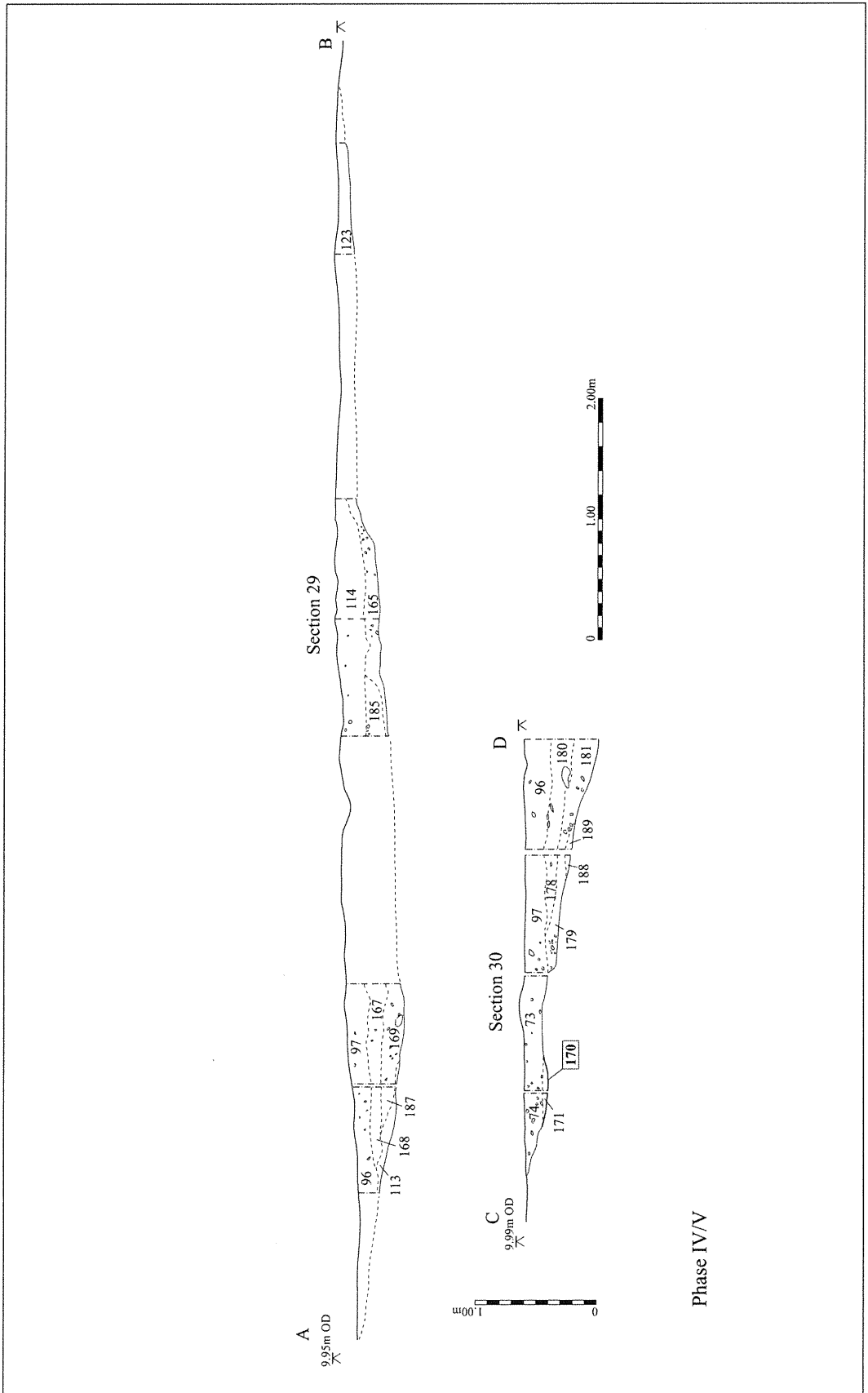

Figure 7 Section across Phase IV and V middens

vi. Phase V Mid to Late Third century

A similar organic material to that which formed the upper/main midden deposit was also observed within the upper fills of the well (112), the uppermost fills of ditches **M17** and **M19**, and gully **293**. Environmental analysis of these fills indicated that the general make up of these samples was very similar to that of the main midden, with evidence of secondary crop processing at a domestic level. The absence of any material of this type from the basal fill of these features would indicate a change in site activity between the earlier phases of the site and later phases, particularly when the earlier ditch features had largely gone out of use.

The ceramic assemblages from these deposits were not sufficient to distinguish between early and later phases of midden related activity. It can, however, be suggested that the movement or spread of midden material beyond the initial 'bounds' of the depression **295** dates to a later phase in the accumulation of material. This was subsequent to the 'standstill' phase and development of buried soil detected by micromorphology and which divides the lower two finds poor deposits of the midden from the artefact rich upper deposits.

Summary of Phase V

The most likely explanation for the final sequence of Roman deposits on the site is that during the mid to late third century the deposition at the midden site was terminated and that midden deposits were used to level existing earthworks within the excavation area. It is however, possible that the quantity of deposits indicates a short period of very intense activity in this area and as a result the disposal of crop processing debris was no longer solely focused on the midden (**295**). In such a case it is likely that the construction of additional middens beyond the excavation area, like those found during the evaluation, would have become the alternative and preferred place of disposal.

vii. Phase VI Medieval and Post Medieval Features

Traces of ridge and furrow cultivation (**M16**) were recorded across the site. The furrows ran from the southwest to northeast, interestingly on the same alignment as many of the Roman ditch and enclosure features, particularly **M18** and **196**. Commonly beneath the furrows lay a ditch **M172** (Figure 5) Furrows were located at approximately 12-13m intervals and truncated many of the Roman features. The fill of the furrows was a dark yellowish brown clayey silt.

In addition, a boundary ditch relating to enclosure, probably during the 19th century, and clearly shown on modern OS maps was recorded along with a series of ceramic, rubble, and limestone capped field drains.

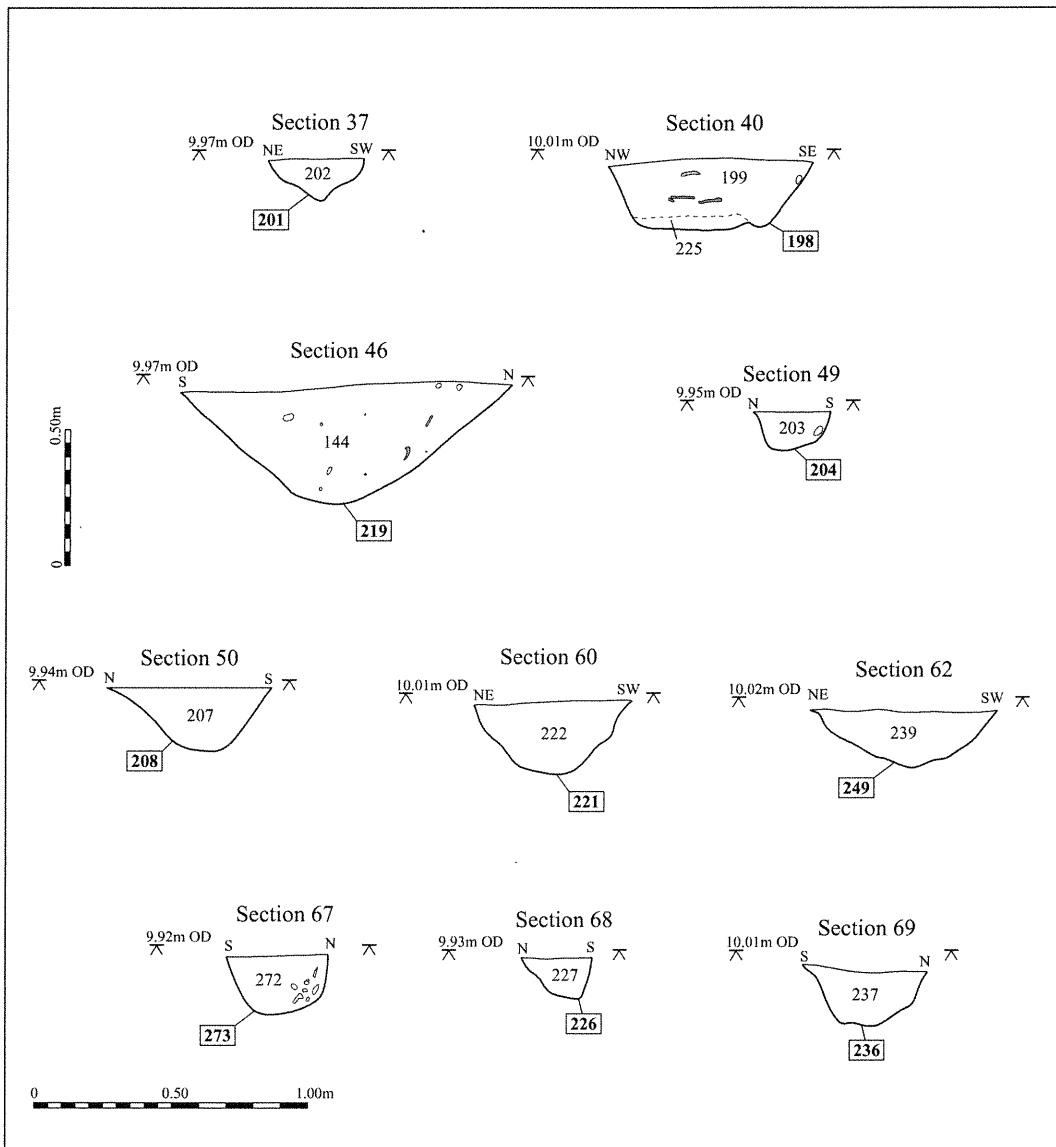

Figure 8 Sections through pits and post-holes. Various Phases.

Summary of Phase VI

Several phases of medieval and post-medieval land division are represented in this phase. The first, **M172**, consists of cut ditches running east-west. These are found beneath many of the furrows and seem to represent an early form of land marker within the strip cultivation system. As these ditches infilled they were replaced by furrows **M16** generated by medieval ploughing. The field system was once again re-formatted at the time of enclosure. The enclosure ditch **M294** was dug and a series of limestone and ceramic drains have been laid to channel water in to the ditch. During the 1980's this ditch was completely infilled in order to combine the fields a series of smaller fields.

The complementary alignment of the Roman and medieval features within the excavation area suggests that significant elements of the medieval landscape, on which the ridge and furrow cultivation were set, had also existed in Roman times. The most likely surviving contender is the north-south ridge which runs through the field west of the A15. Prior to the evaluation this ridge was presumed to be a Roman road, however, no traces of a road surfacing were found during the evaluation and the ridge was subsequently presumed to be a headland or baulk. A similar case has been identified at Eynesbury Cambridgeshire where an eighteenth century baulk connecting Eynesbury with Little Barford has been shown by excavation to post date a Roman trackway (Kemp 1998). It is suspected that this ridge and Roman trackway, with runs parallel to the A15 and to the western side of the enclosure found in the excavation, or a similarly aligned element of the Roman landscape, provided the alignment for the strip cultivation system between Glinton and Northborough.

4. THE ARTEFACTS

i. The Pottery by C.J. Going

The pottery assemblage from the 1996 excavations consisted of 30kgs of material, the vast majority of which was Romano-British, with very few post-Roman wares and no prehistoric material. The overwhelming bulk of the material from the site was of local origin, that is originating within a day's travelling distance of the site. The principal fabrics encountered were Nene Valley colour coats, greywares and shell-gritted wares. The shell-tempered wares were probably, for the most part, products of the manufactories at Bourne (Perrin and Webster 1990). Pottery from further afield included specialist wares from Spain and Samian. There was very little Samian and of this the overwhelming bulk was 2nd century AD plain wares from south or (more usually) Central Gaul. Of interest was a sherd from **104** which appears to be from a rare Brockley Hill type amphora (ABRH), the only British manufactory hitherto identified as making these vessels. Mortaria were restricted for the most part to products of the Nene Valley kilns, mostly from the Lower Nene Valley centres.

The general span of the material was 1st to 4th centuries AD, although the overwhelming bulk is dateable to the second and third centuries AD. It is likely that there was a substantial diminution of the ceramic supply to the site after 250AD. This may indicate abandonment, or more probably, that the use of pottery on the site was substantially lower than at earlier periods. Very little pottery recovered was dateable to the 4th century AD, although one or two features are to be dated to that period, and it seems that there was a diminution in site activity at this time.

ii. Metalwork and Coins by C. Montague

Metalwork and coins were recovered both during the course of excavation and by metal detecting survey. A metal detecting survey was carried out over the entire area of excavation after stripping of topsoil had taken place and prior to commencement of hand excavation. In addition, spoil heaps from both machine cleaning and hand excavation were detected. A survey was also carried out of the area lying to the immediate south of the excavation and of the trenches opened by British Gas to the extreme south.

The majority of metalwork was comprised of iron nails, usually undateable, although a concentration of small iron nails on the upper surface of the midden F295 are presumed to be Roman in date, as is a smaller concentration along the length of M17.

Eleven Roman coins were recovered, of which at least four were Barbarous Radiate dating to the 3rd century, a single coin was of Faustina Junior (146-175AD), whilst a further two could be dated to the 1st century. The others were undateable due to poor condition. None of the coins came from secure contexts.

A bronze nail cleaner and tweezer fragment were recovered from the upper fill of M17. These date to the 3rd-4th century AD and would normally have made up a set of toilet instruments comprising tweezers, ear cleaner and nail cleaner secured together on a small ring through the head loops. An Iron Age/Romano-British 'humped penannular' brooch was also recovered from this same fill (100BC-1st century AD).

An early Roman 'dolphin' type brooch of the 1st century AD (Hattet 1987) was recovered from the upper midden deposit. Brooches of this type, for securing and fastening clothes, are ubiquitous and long lasting in the Iron Age/Romano-British period, and do not indicate anything more than a humble status to the find site.

Later metalwork recovered from the area of the site included a copper alloy buckle of the 14th-15th century, a lead gaming piece, and a 16th century Nuremberg jetton.

iii. Worked Bone by L. Higbee

Two pieces of worked bone were recovered, both appear to be partially finished awls. One is a sheep/goat metatarsal which has a hole through its proximal surface and a highly polished shaft. The distal end has been cleanly chopped off but unworked. The other worked bone is a sheep/goat metacarpal which has a hole through both its proximal surface and its proximal shaft.

8. THE ECOFACTS

i. The Animal Bone by L. Higbee

A small assemblage of animal bone was recovered and examined, concentrating on species determination, skeletal element, age, butchery and pathology. The assemblage consisted of 877 bone fragments (weight 18,877g), 245 of which were identifiable. Cattle, sheep/goat and horse bones dominated the assemblage and are present in all feature types. Rarer elements included pig, dog, bird and rodent; the two bird bones recovered could not be identified to species. Bone preservation was generally quite good, but it is likely that the composition of the assemblage has been altered by canine action. A number of long bones were recorded with gnaw marks at either end typical of canids. The extent to which this is a problem for assemblage interpretation is uncertain, but there does appear to be an under-representation of unfused epiphysis in relation to diaphysis. Ageable material was scant, but was noted wherever possible using the established methods of tooth eruption and wear, and epiphysal fusion of the post-cranial skeleton (Silver 1969). Ageing was possible on sheep/goat bones and mandibles. The fusion method indicates ages of between <3-3.5 years, whilst ageable tooth rows give slightly lower estimates of <21-30 months and 18-48 months. All of these individuals are around the optimum age and size to be culled for meat and all would have produced at least one fleece and possibly as many as three before they were culled. However, it is impossible to be certain of the form of husbandry practised with so few ageable individuals. Only one cattle mandible was suitable for, this was aged to between 24-30 months. Two pig mandibles were ageable, one was an extremely young individual of approximately 7-28 days and may represent a natural neonatal mortality, the other was 16-22 months at death. Age estimates for horse rely heavily on the less accurate epiphysal fusion method which reveals ages of <2 - <3 years. One upper molar was found to be extremely worn and aged at 18-40 years (Levine 1982).

Skeletal representation and fragmentation suggests that the assemblage is mostly food remains. Choice body parts (i.e. the fore and hind limbs) make up about 32% of the total cattle/sheep/goats and pig bones. Butchery marks were noted on cattle, sheep/goat and horse bones only. These take the form of chops and knife cuts which are generally consistent with primary carcass dismemberment and removal of meat from the bone. Common sites of dismemberment noted include the elbow joint (distal humerus, proximal radius/ulna), the hip joint (proximal femur), the mandibular hinge, and the ankle joint (distal tibia and proximal metapodial). The hind and forelimbs of cattle were more

extensively butchered, having been chopped midshaft to produce more manageable joints of meat. Some long bones were split longitudinally presumably for the extraction of marrow. Worthy of note is a cattle skull (frontal and parietal portions) which has a large hole at the back of the left frontal bone near the sagittal suture. Since no new bone had time to form around the injury it would appear that this animal was stunned or pole axed to death. Knife cuts were recorded on only a few bones most notably around the collum (neck) of a cattle scapular and on the skull described above.

A few bones have small, slightly irregular, depressions on them which may relate to hanging the individual joints of meat for some preparation process e.g. filleting or smoking. These holes were noted on a distal sheep/goat tibia and on the collum of a cattle scapular. A more regular hole was also noted on the proximal articulation of a horse radius between the medial and lateral surfaces.

Pathological conditions were recorded on cattle and horse bones only. Full details of these are in the original archive report. Slight exostosis was noted on one horse phalanx prima, the location of which suggests that the animal was put to work. In addition evidence for a condition known as 'spavin' was recorded on a horse metatarsal. This is usually associated with working animals and this animal would have only been capable of slow work (Barker and Brothwell 1980, 118).

Due to the small size of the assemblage, analysis was not attempted within phases of the site.

ii. Plant Remains by D. Schlee

Methodology

An environmental sampling strategy was formulated to be representative of the range of feature types and their spatial distribution across the site. Deposits that looked as if they might be particularly productive (such as fills of well **112**) were also sampled. Sampling was targeted on the midden deposits at the north end of the site in order to ascertain whether there was any spatial variation in the contents of the midden and to compare the midden with similar deposits from the upper fills of the main enclosure ditches (**M17** and **M19**).

It was suggested during excavation that these ditch fills were a product of deliberate deposition of midden materials into the enclosure ditches, rather than a gradual accumulation of sediments. This interpretation was based on the lack of any other midden material in the immediate vicinity of the ditches from which the ditch fills may have derived and the sharp juncture between the two sedimentation regimes within these ditches.

Samples were also taken from linear features that were sealed by the midden deposits. Although these linear features were also found to contain midden material it is thought that these ditches were out of use and partially backfilled by the time the midden was

formed, and that midden material filled the remaining depressions. In addition samples were taken from pits, gullies and the upper fills of the well.

Forty-two samples, of 10 - 20 litres, were processed for the recovery of plant remains using a standard Sirraf-type flotation machine. Flots were collected in 0.5mm meshes and heavy residues in 1.0mm mesh. Samples were sorted using a x10 mag. binocular microscope.

Results

Although seeds were present in both charred and un-charred states, the majority were preserved charred. Most of the weed seeds were not charred. Bearing in mind that the archaeological features were sealed directly below the current ploughsoil and the apparent freshness of some of the seeds, it is likely that many of the non-charred seeds are not archaeologically significant, and may have been worked into the soil bioturbation processes (root insect and worm activity). Other non-charred seeds from deeper deposits are more likely to be ancient (representing plants that grew in the immediate vicinity of the site). Seed preservation indicates that although soil conditions have not been consistently or sufficiently waterlogged to allow good anaerobic organic preservation (with the exception of the well deposits), some of the more robust seed types have nevertheless survived.

Some weed species were present in both charred and uncharred states. This is a consequence of the range of conditions in which the plants will grow. They may be present as weeds of cereal crops (through which association they are likely to become charred) as well as found in non-agricultural environments in the immediate vicinity of the settlement (in which case they are likely to be present in a non-charred state).

The charred material consisted of wood charcoal, charred cereal grains, chaff fragments and grass seeds (including *Bromus* sp.), likely to have been growing among the cultivated cereals. Plant remains preserved by charring are generally more likely to have been of domestic, economic, and agricultural significance, since it is usually through human agency that they have become charred. Consequently, the majority of charred seeds are of cereal crops, chaff fragments and seeds of plants that grow as weeds in arable fields.

Many of cereal grains were not very well preserved, with broken, puffed and distorted grains making identification difficult. The well preserved grains retained little surface detail, but appeared to have retained their shape.

Midden deposits: The deposit was sampled at various points with the aim of distinguishing variation in the assemblages across its horizontal extent. The overall impression is that the assemblages in the different samples from the midden are fairly uniform. While this may indicate that the midden is in fact an homogenised deposit, it may be a result of uniformity in the crop assemblage when the midden was originally deposited. A column sample for micromorphological analysis was also taken to see if

there were indications of a more complex depositional sequence than was apparent with the naked eye.

Within the flotation samples, the quantity and size of other inclusions such as bone and pottery was small, suggesting that it was not a general midden but the result of repeated crop processing in this locality on a very large scale over a long period of time.

The charred seed assemblage recovered from the midden deposit in the evaluation excavation is similar to those of the main excavation, with the same range of weeds, cereal crops and chaff, in similar proportions.

Ditch fills: The upper fills of several of the ditch features also contained midden-like deposits. Although there are superficial differences in the quantities of charred items in the samples from ditches in comparison to those from the midden, this may be due to taphonomic processes as a consequence of their probable relocation and mixing with other material before final deposition. The general make up of the samples is still consistent with secondary crop processing at a domestic level, with no indication of other processing stages or related activities. The absence of charred cereals etc. in the lower ditch fills suggests that the crop processing activities were not carried out at the site from the start and that the ditches had partly filled up with weathering deposits before being backfilled with midden material. The crop processing would therefore appear to belong to a later phase, associated with activity on the site after abandonment of the initial settlement features.

Well fills: The well could not be fully excavated, so no flotation samples were available from its earliest fills. Only later, probably intentional, backfill deposits could be sampled. In addition to a wider and more numerous range of weed seeds that were better preserved in the wetter well deposits, charred crop processing remains were also present, again suggesting that the midden deposits do indeed belong to a later phase of activity and were used as backfill material. An auger was used to obtain a sample of the lower well fill for pollen analysis.

Cereal crops: Six-row hulled barley (*Hordeum vulgare*) grains were only present in four samples, and only then in very low numbers. Although barley is typically common in Roman assemblages its effective absence from these samples suggests that it was neither cultivated nor processed at this site on a large scale.

As is the case in the majority of Roman period sites, Spelt wheat (*Triticum spelta*) grains and glume bases (chaff fragments), were the predominant cereal present in the samples. The quantity of Spelt grains and chaff contained in the extensive spreads of midden material suggests that the secondary processing and probable cultivation of Spelt wheat was the focus of activity at the site.

Emmer wheat (*Triticum diccicum*) grains and chaff were also present in the samples occurring in small numbers apparently alongside the Spelt wheat. Throughout this period Spelt wheat cultivation gradually superseded Emmer wheat and it is possible that all the

Emmer, Barley, and Oats, as well as the wild grasses present in most samples, represent a mixed crop or contaminants among an essentially Spelt wheat crop.

Specimens of Oat grains (*Avena sativa*) were present in low quantities in several samples. In midden deposit sample 10, they were present in larger numbers along with a larger presence of wild grass seeds, perhaps suggesting that both oats and wild grasses existed as crop contaminants and were separated out during secondary cleaning of the main cereal crop.

A few charred specimens of *Pisum sativum* (Field Pea) were recovered. Although a cultivated crop, its low occurrence at the site may suggest it is only present as a cereal crop contaminant, or is present through a different domestic activity to secondary crop processing of cereals.

Weed species: The non-cultivated plant species represented in the samples are plants that grow in a range of habitats including disturbed or waste ground, grassland, hedgerows, or as weeds of arable cultivation. Although some of the species have some potential economic, dietary, or medicinal uses, the character of the features and deposits from which samples were taken suggests that the plants were generally growing in the ditches and open ground in and around the settlement, and are not present as a result of specific utilisation by the inhabitants. Charred seeds of several grass species were present in many samples. These are most likely to have been contaminants of cereal crops, but may represent the more general use of grasses as fuel.

Interpretation

The charred plant remains from the midden deposits contained wood charcoal, cereal grains, chaff fragments and weed seeds. The absence of cereal straw culm nodes, rachis fragments and the relatively high proportions of cereal grains indicates that the deposit does not represent either threshing waste or stored straw.

Alternatively the deposits could contain partially cleaned, stored grain that was accidentally destroyed by fire. If this were the case however, it might be expected to find intact glume bases and spikelet forks and cereal grains entirely encased in chaff. The presence of quantities of fragmented glume bases, weed seeds and otherwise clean cereal grains suggests that the midden deposits are in fact derived from secondary crop processing at a domestic scale. At this stage grain to which the chaff is still attached is lightly parched and pounded. This both enables the adhering chaff to be removed from the grain and improves the ease with which it can be milled for flour. Before use, the grain is sieved to separate chaff fragments and weed seeds. The charred material from the midden therefore is most likely to represent sieved chaff and weed seeds and grain that has been accidentally charred in the parching process.

There is no archaeological or environmental evidence to suggest that the quantity of burnt material represents accidental destruction of stored grain. The apparently large quantity of charred cereal cleaning waste present at the site and the general uniformity in

the range of chaff fragments etc. present in the samples, may suggest that this was an area for specialised large scale secondary cleaning of cereals. Alternatively, it may indicate that the same crop processing activities were carried out in the same place on a smaller scale but over a long period. The archaeological evidence suggests that the crop processing is a later phase of activity. This may be the result of changes in the location of specific activity areas, so that while crop processing may have been carried out throughout the history of the settlement, it only occurs within the excavated area later in the development of the settlement. Alternatively, it may be evidence for a real change in the site economy, possibly from a pastoral to an arable agriculture. This may have been to supply either an adjacent settlement of which the archaeological features at the site are a part, and/or a satellite agricultural settlement to a larger settlement or estate centre nearby. The presence of a further contemporary midden containing a similar assemblage as recorded in the 1995 evaluations gives further evidence of the large scale of the operations.

The weed seed assemblage is unsurprising, indicating arable cultivation, disturbed ground, grassland (possibly pasture) and nitrogen-rich soil associated with human habitation. There are no species present that are sufficiently catholic to suggest more specific habitats existed nearby or were economically exploited. Below, is a list of the Latin and common names of the plants represented at the site.

Ranunculus sp. - Buttercup
Silene vulgaris - Bladder Campion
Stellaria media - Chickweed
Chenopodium album - Fat Hen
Pisum sativum - Field Pea
Potentilla sp. - Tormentil/ Cinquefoil
Daucus carota - Wild Carrot
Polygonum aviculare - Knotgrass
Polygonum convolvulus - Black Bindweed
Rumex acetosa - Sorrel
Urtica urens - Small Nettle
Urtica dioica - Stinging Nettle
Hyoscyamus niger - Henbane
Prunella vulgaris - Self-heal
Galium aparine - Goosegrass
Sambucus nigra - Elder
Achillea millefolium - Yarrow
Carduus sp. - Thistle
Lapsana communis - Nipplewort
Crepis sp. - Hawks-beard
Briza media - Quaking Grass

iii. The Palynomorphs by P. Wiltshire

Introduction

Five samples were taken for palynological analysis. These were analysed with the aims of assessing the palynological potential of the sediments and obtaining some idea of the landscape surrounding the site during the periods of sediment accumulation. The material for analysis was taken from both monoliths and core samples and concentrated on the deposits within the well feature (Fill 116), the basal fill of pond/quarry F47, and the basal fills of two linear ditches [F177 and F216].

Results

Sediments from near to the base of the well contained sparse and poorly preserved palynomorphs. These indicated an area of very open and weedy grassland and rough, open soils. No cereal pollen was found in this sequence but many of the taxa represented might have been weeds growing in arable soils as well as in pasture or rough grassland. The relative abundance of *Urtica*-type and *Potentilla*-type might tentatively suggest soils enriched to some degree by phosphate and nitrogen. The sediments also contained burnt wood elements reflecting local burning. Spruce was also found in this sample (see below).

Sediments from further up the well-fill sequence also contained abundant microscopic charcoal and iron pyrite frambooids, indicative of stagnant water enriched by fermenting organic material. There were also indications that bioactive soil was being introduced into the well at this period. *Alnus* was the only native woody plant which appears to have been growing in the catchment at this time. However, *Picea* (spruce) was present, and is discussed further below. Cereal type pollens were present in this sample indicating that cereals were being grown and/or processed near to the site.

Analysis of basal fills of ditches and pond/quarry produced only very sparse or corroded palynomorphs. In all cases the landscape appears to have been very open with little or no tree/shrub pollen and indications of weedy grassland.

Discussion

It is obvious that there has been differential decomposition within these feature fills and much of the palynomorph load has been lost. Remaining pollen and spores were invariably sparsely represented and considerably corroded. However, the assemblages were varied enough to provide a crude picture of the landscape surrounding the site.

The area was clearly open, with most woodland having been cleared away. However, some alder and oak might have been growing in the catchment, though possibly not very near to the site. The area was dominated by weedy grassland/pasture and open soils with some cereals grown or processed in the vicinity. Some of the weed taxa might well have been grown in cornfields. Some soils might have been somewhat enriched, possibly by human and animal activity.

The assemblage is most remarkable for the find of spruce pollen. This tree is thought to have become extinct in Britain in the Pleistocene and to have been re-introduced in post-Medieval times. However, spruce cones and twigs have been found recently at

Godmanchester (Murphy 1994) and at Stonea (van der Veen 1997), although they were misidentified at the latter site. These finds would indicate that spruce was being introduced, but does not prove that the tree was being grown at these sites. However, spruce pollen was also found in a 4th century well at Godmanchester (Wiltshire 1994) and this provided stronger evidence for the tree having been planted in Britain in Roman times.

The find of spruce pollen at Glington is thus of considerable importance because it implies a wider cultivation than first thought. The spruce at Godmanchester was thought to have been growing in a garden since the macrofossils of a range of garden plants were found in association. Whether the tree was being grown for decorative or utilitarian purposes at Glington cannot be ascertained but it is extremely interesting that it was found widely spread throughout the samples. This implies that the plant may have been present for a considerable (though unknown) period of time, and must have been growing in the vicinity.

iv. Micromorphology by C A I French

Introduction

A series of three soil blocks for micromorphological analysis were taken from the midden deposit in Trench II. Preliminary assessment of this deposit had indicated that this Romano-British feature contained abundant crop processing debris and occupation-type artefacts (Welsh 1995). This material appears to be acting as a 'spread' of material over a large area of earlier features and a stabilisation zone or secondary 'old land surface'. As a form of 'dark earth' deposit it was sufficiently rare and important to warrant full micromorphological analysis. Micromorphological analysis followed the methodology of Murphy (1986) and the terminology of Bullock *et al* (1985).

Description

In the field, the midden appeared to be an homogeneous deposit of dark greyish black silty clay loam, about 20-25cm thick, in places acting as tertiary feature fill and in other areas sitting on the poorly preserved remains of the old land surface. This was sampled in two loci. In thin section the stratigraphy was considerably more variable and complex. Detailed description is available for consultation within the site archive.

Interpretation

There is a thin soil-like horizon overlying some of the shallow pond/quarry features. The small amount of illuvial, oriented clay within the fine groundmass makes this horizon resemble a cambic or lower B horizon of a rather poorly developed brown earth. Certainly this soil type typically forms on gravel terrace subsoils (Avery 1980), and has regularly been observed in prehistoric contexts in the lower Welland valley region (French in Pryor and French 1985; French 1990). In this case, its formation and survival

is undoubtedly associated with the combination of the extra degree of burial afforded by the midden, effectively protecting this remnant of soil from destruction through recent ploughing, and post-feature fill soil accumulation and development in the shallow hollow created by other similar features. Although not directly provable through relict soil features, this secondary soil horizon may have partially developed as result of a brief period of arable use and then stabilisation during Phase IV.

Two different sets of stratigraphy through the midden were observed in the two micromorphological profiles taken. As they are different, but variations on the same fabric theme, it is possible that there was considerable amorphous growth to the feature, and that clear visual evidence of these construction aspects has been disguised by subsequent soil mixing processes.

Profile 2 exhibited an homogeneous fabric composed of bioturbated, formerly organic-rich, iron impregnated, sandy clay loam. The relatively abundant, finely comminuted, amorphous organic material, now mainly oxidised and/or replaced by sesquioxides, plus occasional fine fragments of animal bone, burnt soil and probable herbivore coprolites suggests that this may have been a former organic A horizon which was receiving midden-type material, both organic and inorganic in origin. If there was any horizonation, this has been destroyed by post-depositional soil faunal mixing. Subsequently, this soil has received illuvial fine material (silty clay), most probably as a result of recent agricultural disturbance. Effectively, this former organic A horizon containing midden material is acting as a B horizon to the modern ploughsoil.

Thus, this accreting former A horizon was effectively 'bulked-up' by the repeated addition of organic debris, but it was subject to continual oxidation and bioturbation, breaking down the organic component. Although it cannot be proven by this method of analysis, this midden area may even have been contained by some sort of barrier, or just located in a corner of a field whose boundaries are no longer recognisable, and perhaps used as a horticultural/garden plot.

In contrast, Profile 1 exhibited much microstratigraphy. It consists of several discrete episodes of deposition of midden and soil material, developed on the base of a brown earth soil and the clay-rich gravel terrace subsoil. These episodes are represented by thin, alternating horizons of micro-aggregated (or excremental fabric), fine sandy clay exhibiting various degrees of ped structure and impregnation with sesquioxides. Throughout, almost all of the organic component has been reworked by the soil faunal and/or replaced by sesquioxides.

Where there is a fine blocky ped structure developed (at 30-30.5 and 31.5-33cm), these horizons may represent a temporarily stable upper surface which became 'grassed-over' for a short period, before there was further deposition of midden material and soil. In addition, there is one possible standstill horizon at 38-39cm with a sharp upper boundary composed of strongly sesquioxide impregnated very fine sandy clay. This could represent a zone of trampling, exposure, puddling and oxidation. Or, it could simply be a post-depositional feature formed as a result of a textural change and/or a temporary barrier to

water movement such as caused by a piece of wood or leather/hide/leaf material, now long since decayed.

Conclusions

In summary, the micromorphological analysis of this Romano-British midden has suggested that this deposit was a gradually accreting, episodic, organic-rich midden. There was a period of pre-midden and post-pit, secondary soil development which resembles the lower B horizon of a former brown earth, which was a result of weathering and/or possibly ploughing. This secondary soil and the midden deposit have been subject to considerable post-burial oxidation, soil faunal mixing and impregnation with iron oxides and hydroxides associated with a fluctuating groundwater table. There remains the possibility that the midden exhibited considerable variation in composition and accumulation over time across its area. The apparent longevity of this midden is further corroborated by the analysis of the Roman pottery contained within it.

9. PHASED DISCUSSION OF THE LATE IRON AGE AND ROMAN ARCHAEOLOGY.

Area excavation, combined with extensive environmental sampling and targeted micromorphological examination, has enabled an examination of the activity and economy of the small local rural settlement. Although the local and domestic nature of the ceramic assemblage has made it difficult to assign absolute dates to the different phases and types of activity encountered, nevertheless the stratigraphic evidence allows a discussion of the overall changes in layout of the site. These can then be examined with respect to the main features from each phase, and accompanying environmental and economic evidence.

The following discussion also attempts to integrate the evidence from the 1994 evaluation into the results from the 1996 excavation to broadly define the nature and economy of the site.

i. Phases I and II First Century - Late 2nd Century AD

The earliest phase of activity on the site can be dated to the 1st century AD, with no evidence for an Iron Age component in the ceramic assemblage. This suggests that there was little or no continuity between Iron Age and Roman activities at this site, with only the Iron Age 'humped' and dolphin brooches indicative of Iron Age activity at all. However, given that any settlement area associated with the site appears to have been concentrated to the west of the area excavated at Glinton it is possible that evidence for continuity may exist elsewhere in the settlement or other activity zones. Evidence for continuity between the Late Iron Age and the later 1st century has been recorded at many of the Fenland and Fen Edge sites of the area, such as those at Werrington (Mackreth 1988), Plant's Farm Maxey (Simpson et al 1993), or Maxey (Pryor et al 1985), and therefore may have been expected within this settled area. Certainly the main features of

this first phase, the large enclosure ditch and southernmost linear ditch, and the interrupted enclosure ditch which immediately post dates this, are typical of the type of features expected on sites with continuity through this Iron Age/Romano-British period.

The enclosure ditch has a substantially larger diameter than those recovered on similar period sites along the fen edge. Perhaps the nearest in type might be that from Werrington (Mackreth 1988) where, in addition to a smaller more typical structural 'eaves drip' gully, a 15m diameter ring ditch was recovered. The width (2m maximum) and depth (0.70m maximum) of this feature, combined with the lack of any internal features, must cast some doubt over its interpretation as a dwelling/structure. However, Mackreth proposed that this Iron Age ring ditch at Werrington delineated a raised platform formed from the upcast of ditch digging, and that any structural remains along with the platform material were truncated by subsequent ploughing. He thus argued for an interpretation of a domestic structure. In terms of diameter the enclosure at Glinton (27m minimum - 33m maximum) is considerably larger than that at Werrington although the ditch sizes are not dissimilar in scale (Glinton 1.68m wide, 0.83m deep). In the case of Glinton it seems highly unlikely that the enclosure was a domestic structure; instead it would appear that it was related either to a stock enclosure or delineation of settlement area. Glinton lies about 2km from Werrington and there may be a close connection between the two sites.

A similar interpretation might be placed on the probably rectangular enclosure **M17** of the subsequent phase. This enclosure, of which only the east and north sides were recovered, forms a substantial boundary, again delineating an area lying to the west. Similar enclosures have been noted in slightly earlier contexts at Maxey, Plant's Farm Phase 2 (1st century BC-AD) (Simpson et al 1993), and Werrington, Period 1 and 2 (2nd or 1st century BC-50/60AD and 50/60AD-c100AD) (Mackreth 1988).

The sub-rectangular boundary during this phase truncates the final infill of the previous enclosure ditch and follows the line of this boundary on its eastern side. This boundary ditch appears to have gone through at least three phases, with initial cut being partly filled prior to the re-instatement of the boundary with firstly posts and then a re-cutting of the ditch. This re-cutting appears to respect the entranceway into the enclosure.

Again, there is little evidence for actual settlement structures within the excavated area during this phase of the site. However the evidence for beam slot structures and gravel surfaces in the adjacent evaluation trenches suggests that the activities evidenced in the main excavation area were undertaken close to a settlement focus.

Few macro-environmental remains date to this phase and there is no evidence for the type of large scale crop processing evidenced in Phases IVb and V.

The ditch and ditched post-boundaries typifying this phase may indicate stock enclosures and animal husbandry activities. Unfortunately the small quantity of animal bones was not susceptible to analysis by phasing and it is therefore not possible to use this to interpret the site animal economy at this specific phase.

ii Phase III Late Second and/or Early Third Century

Phase III sees a substantial change in the reorganisation of the site with expansion of ditched enclosures to the central and eastern areas. This reorganisation would appear to suggest a shift in the focus of activities and /or economy of the site, with less emphasis on larger, centralising, ditched enclosures and more complexity of land division. These narrow ditches may represent field and paddock or compound boundaries, some of which are spatially related to later shallow/pond/quarry features in Phase IV. Re-orientation and expansion of the settlement and agricultural structure of a site has been noted elsewhere in the region. Where recognised it has been linked to the mid-second century Imperial intervention in the marginal lands of the Fens (Potter 1989, 159) and the construction of the Car Dyke 1.8km to the east of the site which would have had implications for regional access and drainage (Mackreth 1989, 87).

The Roman site at Werrington is argued by Mackreth to have undergone substantial re-definition of both the spatial arrangement and economy of the site in the 2nd century (Werrington Period 3). This is exhibited by a change in focus from a large enclosure, similar to Phase II at Glinton, to a complex of shallow ditch features forming rectangular enclosures, seen in Phase III at Glinton (Mackreth 1988, 77-80).

Mackreth argues that this redefinition may be seen as a 'direct outcome of Roman development in the Fens' (1988, 80) as the construction of Car Dyke in the early 2nd century cut off the settlements on the fen edge from the uplands which had once been available to them. Specifically Mackreth suggests that this led to an increased diversity in economy, away from a pastoral dominated one, towards a more complex economy in which arable production played a larger role, a suggestion that accords well with the data from Glinton. Alongside this Mackreth sees a shift towards cattle rearing and away from sheep husbandry. Sheep exploitation in the later periods at Werrington also shifted from that of meat to concentration on wool production. This would also agree with Grant's assessment of the growth of wool production during the Roman period (Grant 1989, 139). Although the animal bone at Glinton could not be phased a concentration on wool production is suggested by the sheep bones which indicates the potential for several fleeces being cropped prior to the death of any individual.

iii. Phase IV Early to Late-Third Century

The main phase of Romano-British activity at Glinton in terms of artefacts recovered during these excavations appears to date to the early to late third century. There is little evidence from the ceramic assemblage of the importation of pottery onto the site after this date.

During the first part of this phase we see dispersal of activity over most of the excavated area. Three main concentrations of activity can be discerned. Firstly, the central area which contains a number of linear gullies, an interrupted curvilinear feature and a stone-lined well. Secondly an area to the northeast where small gullies and hollow suggest the

delineation of a midden area prior to deposition of midden material, and thirdly a series of small intercutting gullies extreme northwest corner of the site.

The activity within the central area, with its gullies and associated features may be interpreted as indicative of structures defining activity areas. Truncation of the features made exact interpretation difficult other than in the case of the well. It may be suggested that some of the gullies could have formed boundaries and structures focused on the well itself, or perhaps served to associate the interrupted curvilinear with the well.

In the north several gully features, in particular on the immediate southeast side of the midden hollow, appear to represent boundary/structural features of a similar type to those in the central area. In the extreme northwest corner of the site a further series of narrow intercutting gullies and slots were unfortunately too heavily truncated to allow interpretation other than as further indication of the dispersed nature of activity over the site at this period.

In addition to the concentration of features in these areas several irregular 'quarry pits' or 'hollows' are constructed along the lines of the ditch boundaries of Phase III. The placement of these cut features may suggest either slighting of these boundaries or, perhaps more likely, activity at the edges of areas delineated by these ditches (i.e. at the edges of the paddocks/fields created during the previous phase) was extended as the process of extraction expanded.

Following the creation of the quarry/hollow feature in the northeast, we see a period of standstill, during which a sediments soil accumulate in the base of **295**. This standstill period has been suggested by French as associated with a period of arable cultivation in the vicinity of the site. The commencement of the deposition of large quantities of midden material in this area (and in the subsequent phase across the whole site) is fundamental to the interpretation of the final phases of the site and indicates the presence of large scale secondary crop processing. Analysis of this material, both from the midden and the tertiary fills of some of the linear features has provided much information about the economy and function of the site in this latest phase and this may be usefully integrated with the results of the palynomorph analysis. The beam slots and gullies indicative of structures recovered adjacent to the area of the midden during Phase IV and also during the evaluation suggests that this activity took place within well-defined and discrete areas during this phase.

The quantity of Spelt grains and chaff contained in the midden indicate that secondary processing and probable cultivation of Spelt wheat was the focus of activity at the site at this period, with the small amounts of barley, emmer and oats most probably appearing as crop contaminants. The large amounts of this cleaning waste, and its uniformity both within the midden deposit and within the upper ditch fills suggests specialisation at the site. This is emphasised even further by the similarity between the midden material recovered during the 1996 excavations and that of a different midden recovered during the 1995 evaluation.

Palynomorph analysis from the basal fills of the well and the basal fills of the quarry/hollows associated with this phase indicate a very open environment dominated by weedy grassland and possibly enriched arable. Although there was no evidence of cereal pollen in the very basal levels cereal pollen was recovered from the fills above these, the poor ceramic sequencing and correlation makes exact phasing difficult. The recovery of Spruce pollen from these levels will be discussed below, but may indicate purposeful planting in association with this Fen edge settlement.

iv. Phase V Mid to Late Third Century

This phase may be characterised by cessation of most types of activities with the exception of the continuation of the import and deposition of secondary crop processing materials on a substantial scale. Midden material was recovered from the upper fills of several of the ditches, including those gullies and beam slots, which delineated the midden in its earlier phases. The deposition of these midden sediments in ditches as well as within mounds possibly suggests the expansion of secondary crop processing on-site and therefore an intensification of crop processing. Alternatively, given the delineation of these activities in the earlier phase it is more likely that the site has fallen in to disuse and the midden sediments have been used to level off the site in preparation for other activities.

Palynomorph analysis indicates that the well began to infill with bioactive soil and became stagnant during this period and this would indicate that it had fallen out of use and supports the abandonment scenario described above.

10. CONCLUSIONS

The excavated evidence from this small rural Romano-British site may be usefully discussed within the context of similar sized rural settlements within the Fen edge/Lower Welland Valley area, and in its role within the hierarchy of larger settlements and features within the area.

In its initial phases the site appears to display many similarities with other small rural sites, such as that of Werrington, Maxey, and Maxey Plant's Farm (Mackreth 1988, Pryor 1985 etc.). Although little evidence has been recovered for actual house remains, the Phase I and Phase II enclosures both have parallels with other rural Romano-British sites. The fact that only the eastern edge of these features were recovered within the excavation area may suggest that the actual settlement lay further to the west under the present road and linked to the postulated Roman trackway on the western side of the A15. The type and quantity of ceramic assemblage from this period, indicate purely local 'trade' links, whilst the absence of evidence for any crop processing in this early phase combined with the evidence for cattle/sheep/goat domination of the animal assemblage might indicate a pastoral dominated economy. This would suggest in turn the exploitation of the better

drained gravels and perhaps extension into exploitation of the 'upland' areas to the west. Other than the two 1st century coins found in the vicinity of the excavations there is little evidence for anything other than what has been described by Pryor as a site type of 'the lowest possible level in the agricultural economy of the region' (1985, 232).

In the succeeding phases however, we see a re-orientation and re-definition of the site along very different lines and these can perhaps best be interpreted within the wider context of Roman settlement of the Fens. As has been discussed above, the beginning to middle of the 2nd century saw substantial changes in the economic organisation of the Fenlands. Potter has outlined the slow development of the Fens until the 2nd century and gives support to the argument that the massive development during the Hadrianic period might best be seen as the result of Imperial intervention on state owned land (1989, 159). The construction of the Car Dyke, 1.8km to the east, and the growth of Durobrivae 8km to the south, must have had a fundamental impact on the local economy in terms of the availability and accessibility of resources and also the number of potential markets for their produce.

In response to these developments Glington developed a markedly different economic strategy from those previously excavated in the region. Neither the sites of Maxey, nor of Werrington have provided any evidence for secondary crop processing on any scale comparable with that at Glington. There were no substantial macro-environmental remains at Werrington (Mackreth 1988), whilst at Maxey the botanical evidence was indicative of 'normal domestic activities associated with the cleaning of grain prior to consumption and domestic usage', although, in common with Glington Spelt was the most common grain during the 1st and 2nd century phases (Pryor 1985, 230). The Fengate (Cat's Water) site was situated on much lower lying land closer to the actual Fen than Glington and had little evidence for either grain production or consumption (Pryor 1985, 232). If the large scale secondary processing found at Glington is seen as grain production for export off site, we must look not to other farmstead sites for the consumers, but, to sites at different levels in the settlement organisation hierarchy.

At the villa site of Helpston approximately 4km distant from Glington cereals were attested within the deposits but appear to have been actually processed elsewhere, whilst at Stonea the grain (primarily spelt) was brought onto the site in a ready threshed state (Potter 1989). Both these sites are contemporary with the site at Glington, with Stonea in particular being founded in the Hadrianic period at a time when we see a massive reorganisation of the Glington site. The role of Stonea Grange has been subject to much discussion and it is currently proposed as an administration centre and as such a 'consuming' rather than 'producing' site (Potter 1989, 165). Similarly the growth of Durobrivae again from the beginning of the 2nd century onwards, would have produced a 'consuming' market for grain and other goods produced elsewhere. The type and quantity of processing carried on at Glington are considered to be sufficient to suggest that the site was actually supplying either an adjacent settlement (of which the archaeological features at the site are a part), or, more probably, a larger settlement or estate centre nearby.

Evidence suggests that at some time during the second century the site developed from a pastoral based economy, in the tradition of, if not directly derived from the Iron Age settlement in the area, to a more complex mixed agricultural settlement area with a re-orientation of layout. This change was perhaps linked to changing conditions and resources, in particular the construction of Car Dyke and changes in local environmental conditions. Following this, the influence of larger or more specialised consuming sites in the area, perhaps including the nearby villa sites, as well as more 'distant' sites such as Stonea and Durobrivae appear to have led to specialisation in Spelt production for export off site. This may also have been combined with the rearing of sheep for wool, although lack of clear phasing in the animal bone analysis means this cannot be specifically linked to any one phase of the site. It is interesting that, if wide-scale or frequent contact is being maintained with these other non-farmstead sites, there is little in the ceramic assemblage, or metalwork finds to indicate import of goods onto the site.

The collapse and probable abandonment of the site in the mid-3rd century can also be mirrored at other farmstead sites, such as Maxey, as well as the collapse of the 'official' complex at Stonea Grange. Potter (1989) has linked the collapse of these sites to a significant re-orientation in the organisation of the Fenlands at this period. This re-organisation may be linked both to changes in the environment, with an increase in flooding and waterlogging evidenced at several sites within the area, and also a more general restructuring of the procuratorial system on Imperial estates (Potter 1989, 171).

The evidence for the growth of Spruce at Glington is of considerable importance in that it confirms the introduction of this tree into the area of the Fens during the Roman period, an importation also identified at Stonea. This introduction and cultivation may again be linked with the Hadrianic colonisation of the area and further investigation now needs to be carried out on the possible role of the Spruce in the Romano-British Fen Edge environment and economy. Spruce pollen was found widely within the fills of three of the features at Glington with the implication that it was present for a considerable (though unknown) period of time.

Excavations at Glington in 1996 have contributed considerably to our knowledge of the economy, organisation and hierarchy of Romano-British sites in the Fen edge and Fenland area. The results have both confirmed the presence and prevalence of a type of low status 'farmstead' site throughout the period, and provided new evidence of a type of specialised crop production site serving 'consumer' sites. Changing conditions, both environmental and organisational, may have led indirectly to the collapse of these more specialist 'farmstead' sites.

11. ACKNOWLEDGEMENTS

The Archaeological Field Unit would like to express its thanks to WS Atkins Consultants Ltd and Cambridgeshire County Council Environment and Transportation Department

who commissioned the excavations, Mr Graham Clay (the Agent) and Mr Neaverson (the Farmer) for their interest. Mr King who both assisted with this survey and also brought his finds from earlier detection surveys of the immediate vicinity to be catalogued, and the Peterborough and Soke Metal Detectors Club. I would like to thank members of the Archaeological Field Unit, particularly Ben Robinson and Tim Malim who managed these excavations, Dr. Twigs Way who provide much assistance in the post-excavation and research programme, and also to the volunteers who worked on the site.

12. BIBLIOGRAPHY

- Avery, B.W. 1980. *Soil classification for England and Wales*. Soil Survey Technical Monograph 14: Harpenden
- Baker, J. and Brothwell, D. 1980. *Animal Diseases in Archaeology*. London and New York: Academic Press.
- Bullock, P. et al. 1985. *Handbook for soil thin section description*. Waine Research
- Fowler, E. 1960. The Origins and Development of Penannular Brooches in Europe. *Procs. Prehist. Soc.* **XXVI**. 149-177
- French, C. A. I. 1985. Soils and Sediments, in F Pryor and C French *Archaeology and Environment in the Lower Welland Valley*, East Anglian Archaeol. Rep. 27: 205-216
- French, C. A. I. 1990. Neolithic soils, middens and alluvium in the Lower Welland valley, *Oxford Journal of Archaeology* **9**: 305-311
- Hattet, R. 1989. *Ancient Brooches and Other Artefacts*. Oxbow Books. Oxford.
- Hall, D. 1987. *The Fenland Project, No.2: Fenland Landscapes and Settlement between Peterborough and March*. East Anglian Archaeol. Rep.35.
- Hingley, R. 1989. *Rural Settlement in Roman Britain*. London: Seaby
- Kemp, S. 1998. Neolithic and Bronze Age Ritual Landscape at Barford Road, Eynesbury, St. Neots. Cambridgeshire County Council Archaeological Field Unit. Report No.148.
- Levine, M.A. 1982. The use of crown height measurements and eruption wear sequences to age horse teeth, in Wilson, B Grigson, C and Payne, S. (eds.) *Ageing and Sexing animal bones from archaeological sites*. Brit. Archaeol. Rep. British Series 109: Oxford: 223 -250
- Mackreth, D.F. 1988. Excavation of an Iron Age and Roman Enclosure at Werrington, Cambridgeshire, *Britannia* **19**: 59-151
- Murphy, C.P. 1986. *Thin section preparation of soils and sediments*. AB Academic: Berkhamstead.
- Murphy P.L. 1994. Assessment of macrofossils. In McAvoy F. Rectory Farm, Godmanchester. PXA and UPD. English Heritage.

- Perrin, J. R. and Webster, G. 1990. Roman Pottery from Excavations in Normangate Field, Peterborough 1962-3, *J. Roman Pottery Stu.* 3, 1990, 35-62
- Potter, T.W. 1981. The Roman occupation of the central Fenland. *Britannia.* 12. 79-133.
- Potter, T. W. 1989. Recent work on the Roman Fens of Eastern England and the question of Imperial Estates. *J. Roman Archaeol.* 2. 267-75.
- Pryor, F. et al., 1985. *The Fenland Project, No. 1: Archaeology and Environment in the Lower Welland Valley. Vols. I & II.* East Anglian Archaeol. Rep. 27
- Reynolds, T. 1994. *A15 Werrington to Glinton Upgrading: An Archaeological Desktop.* Cambridgeshire County Council Archaeological Field Unit. Report No. A28
- Silver, I.A. 1969. The ageing of domestic animals, in Brothwell, D and Higgs, E. (eds.). *Science in Archaeology.* 2nd ed. London: Thames and Hudson: 250-268.
- Simpson, W.G. et al. 1993. *The Fenland Project No. 7: Excavations in Peterborough and the Lower Welland Valley 1960-1969.* East Anglian Archaeol. Rep. 61.
- Welsh, K. 1995. *Romano-British Remains at Glinton. Archaeology on the A15 Glinton to Werrington Bypass.* Cambridgeshire County Council Archaeological Field Unit. Report No. 111
- Wiltshire, PEJ. Et al 1994. Microbially-derived metallic sulphide spherules, pollen and waterlogging of archaeological sites. In Davis OK. (ed) *Aspects of archaeological palynology: methodology and applications.* American Association of Stratigraphic Palynologists Contributions Series 29. 206-221.



Cambridgeshire
County Council

Education, Libraries
and Heritage

The Archaeological Field Unit
Fulbourn Community Centre
Haggis Gap
Fulbourn
Cambridge CB1 5HD
Tel (01223)
Fax (01223) 880946