

# **Medieval and Earlier Remains at The Old Music and Drama Centre, Brookside, Huntingdon**

Spencer Cooper HND, BA, MSoc Sci and Paul Spoerry BTech, PhD

1998

Editor Paul Spoerry BTech, PhD  
Illustrator Jon Cane BA

*Report No. 152*

©Archaeological Field Unit  
Cambridgeshire County Council  
Fulbourn Community Centre  
Haggis Gap, Fulbourn  
Cambridgeshire CB1 5HD  
Tel (01223) 881614  
Fax (01223) 880946

Arch.Field.Unit@libraries.camcnty.gov.uk  
<http://www.camcnty.gov.uk/library/afu/index.htm>



## CONTENTS

1	INTRODUCTION	1
2	TOPOGRAPHY AND GEOLOGY	1
3	ARCHAEOLOGICAL AND HISTORICAL BACKGROUND	1
4	METHODOLOGY	5
5	RESULTS	5
6	DISCUSSION	9
7	CONCLUSION	11
8	ACKNOWLEDGEMENT	12
9	BIBLIOGRAPHY	12
	APPENDIX A POTTERY SPOT DATING	13
	APPENDIX B FINDS TABLE	14

### LIST OF FIGURES

<i>Figure 1</i>	<i>Plan showing development area and position of archaeological trenches</i>	2
<i>Figure 2</i>	<i>Plans of Trenches 1, 4 and 6 with representative schematic sections and key Trench 6 sections</i>	6
<i>Figure 3</i>	<i>Map of medieval Huntingdon showing course of defences, surviving churches and archaeological excavations</i>	10



## **SUMMARY**

*Between October 19th and November 2nd 1998 the Archaeological Field Unit of Cambridgeshire County Council carried out an archaeological evaluation at the Music and Drama Centre, Brookside, Huntingdon (TL2385/7210). The work was commissioned by CCC Resources Directorate, Property and Contract Services.*

*The results from the evaluation in the southern part of the development site revealed significant remains of a zone of medieval buildings outside of the medieval town ditch. In the northern part of the site the evaluation identified medieval quarrying and earlier features which may represent prehistoric activity.*

*In establishing the presence of medieval suburban development on a secondary north east-south-west thoroughfare, this evaluation has made an important contribution to the understanding of medieval Huntingdon.*



## **1 INTRODUCTION**

- 1.1** Between the 19th October and 2nd November 1998 the Archaeological Field Unit of Cambridgeshire County Council carried out an archaeological evaluation at the Music and Drama Centre at Brookside, Huntingdon (TL2385/7210). The work was commissioned by CCC Resources Directorate Property and Contract Services before the proposed construction of a food outlet with associated car parking. The evaluation was undertaken in accordance with a Brief produced by the County Archaeology Office and to a specification approved by that office (CCC AFU Specification PS/98/11).
- 1.2** It was hoped that this evaluation would establish evidence for pre-conquest and post-conquest medieval activity in this area and aid us in understanding the development of medieval Huntingdon.

## **2 TOPOGRAPHY AND GEOLOGY**

- 2.1** The site is located on the current Huntingdon ring road, which is the supposed line of the medieval town ditch and lies about 200m north east of the High Street and the historic core of the settlement (Figure 1).
- 2.2** The geology of Huntingdon is composed of 1st and 2nd terrace River gravels overlying Oxford Clay. The site lies on the land that slopes very slightly from north to south, but is around 10.50 OD in the centre of the site. Immediately beyond the southern edge of the site lies Brookside /the ring road which follows the outside of the medieval town ditch. This is a semi-canalised stream that formerly meandered along this slight valley bottom joining the river Ouse some 700m to the east. This shallow valley separates the site from High Street zone. North of the site the land rises to around 15m OD, some 200m from the site at a point formerly known as Ambury Hill.

## **3 ARCHAEOLOGICAL AND HISTORICAL BACKGROUND**

### **3.1 Prehistoric Background**

- 3.1.1** The subject site is situated within the Ouse Valley which is rich in prehistoric remains. During the late Neolithic and Bronze Age, major ritual complexes sprang up and evolved along the course of the Ouse and although much of the material culture does not survive these monuments are highly visible from the air as crop marks. These ceremonial complexes cover extensive territories and are distributed evenly across the landscape.
- 3.1.2** Late Neolithic and Bronze Age ceremonial complexes are commonly respected by Iron Age settlement activity which appears to occupy lands away from the river system. This is probably as a result of the episodic alluviation along the Ouse during the Iron Age and Roman periods.



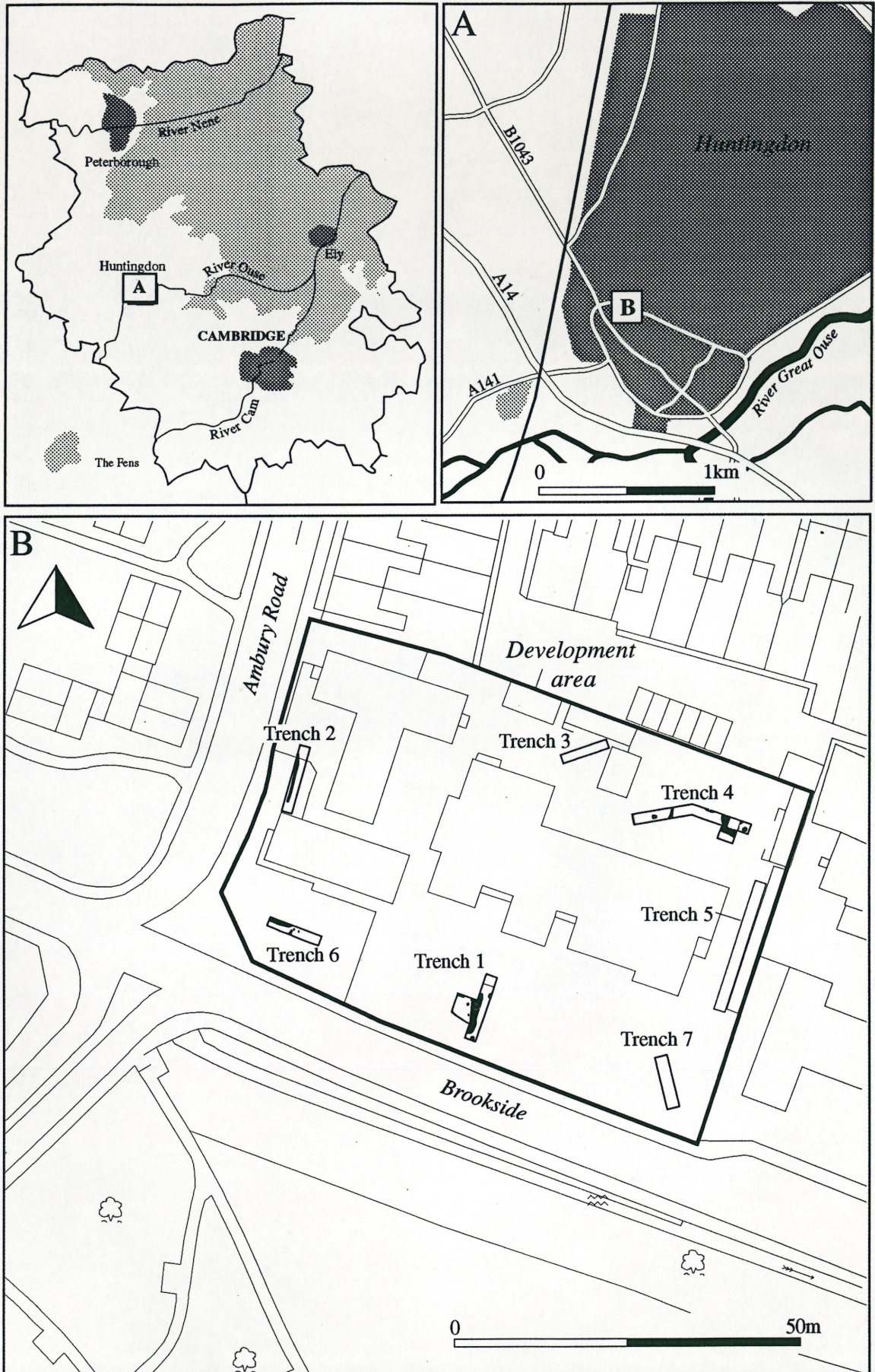

Based upon Ordnance Survey mapping with the permission of the Controller of Her Majesty's Stationary Office Crown Copyright. Unauthorised reproduction infringes Crown copyright and may lead to prosecution or civil proceedings. (Cambridgeshire County Council licence No. LA 07649X 1998)

**Figure 1** Plan showing development area and position of archaeological trenches



- 3.1.3** Within Huntingdon artefacts of prehistoric date have been found and reported to the SMR. These are largely of Neolithic and Bronze Age date. The presence of such artefacts is unsurprising given the preference of early prehistoric populations for low lying gravels and the major late Neolithic ceremonial complex at Rectory Farm Godmanchester, which lies about 1km to the south-east of the development area. The site consisted of a huge rectilinear "horned" ditch enclosure approximately 6.3ha in area, with an internal bank and 24 posts arranged regularly along the perimeter of the enclosure. Radio-carbon dates from the site suggested a late Neolithic date of between  $5050 \pm 80\text{BP}$  and  $\pm 4850 \text{BP}$ . Excavations by the AFU south of the enclosure indicate that the activities associated with the monument were of a wide spread nature (Hinman & Kenney 1998).
- 3.1.4** To the west of Huntingdon lies the late Neolithic and Early Bronze Age ceremonial complex of Brampton. Mortuary enclosures, cursus monuments and ring ditches have been identified. In 1992 an Iron Age settlement was identified to the west of the main complex, whilst a Neolithic and Bronze Age settlement was excavated by the AFU at the Huntingdon Racecourse (Malim & Mitchell 1992, Macaulay forthcoming).

### **3.2 Saxon (Pre-Conquest Medieval)**

- 3.2.1** Recent research seems to suggest that the late Saxon settlement of Huntingdon is located in the southern part of the area later enclosed by the medieval town ditch in the north-east and the *bar dyke* in the south-west (Sperry forthcoming). This is, however, a general suggestion rather than a certainty and this area may not in fact include *all* elements of pre-Conquest Huntingdon. In particular there is much dispute as to the location of the late ninth/ early tenth century Danish burh. One model, although not the most favoured, is based on the comparative situation at Stamford (Mahany 1982) and would place the burh at a defensible location north of the river crossing, as opposed to around the river crossing which tends to form the basis of other interpretations, including that most favoured by this author (Sperry op. cit.).
- 3.2.2** The Stamford-type model is given credence at Huntingdon by the presence of the place name 'Ambury Hill' which is found in both the 1572 Survey (Dickinson 1972) and the town parish enclosure maps, and represents the low rise immediately north of this site. If the area given this name has had boundaries at any point in the past then they are most likely to have persisted in the topographical-derived curvilinear form of the fields south of the Horse Common Lane and east of the water course from Spring Common. This parcel of land has its natural southern boundary at the town ditch and its east side may well have been at Priory road. This latter was formerly called Priory Lane and Straight Lane, and in the medieval period was probably the north western edge of the Priory Precinct. Thus the Brookside site forms a piece of a much larger area of land that has distinct boundaries and had the general name of Ambury/Ambry Hill or Smore/Smer hill in medieval documents. The 'bury' part of this place name is the significant piece of evidence. This could be purely a toponym recognising the higher ground; however, it may instead recall a defence work of some sort, presumably utilising the natural rise. If this were the case then it is either a medieval description of the surviving earthworks of a prehistoric enclosure, or it is a medieval memory of the Danish burgh defences.
- 3.2.3** The complete absence of any SMR information in the whole of the Ambury Hill area (except one late medieval token which represents casual loss in the



fields) does not necessarily disprove that burghal remains, or any other archaeological site, were present. It must be said, however, that the lack of any records of finds from earlier building works does suggest that the discovery of a burghal site must remain only a remote possibility.

### 3.3 Medieval (Post-Conquest)

3.3.1 The date at which the stream that pre-dates the town ditch was formalised into the town limits/defences is not known, although a twelfth century charter identified this as 'the kings ditch' (Hart 1966). By this time it must therefore have already been a recognisable property boundary delimiting the lands of the Priory of Huntingdon to the north, from a quarter of the town called 'Berneys' to the south (op. cit.).

3.3.2 Archaeological, documentary and landscape historical evidence points to this location being undeveloped throughout the post-conquest period. Fieldwork suggests activity along secondary street frontages on the west side of town in the period prior to the mid-fourteenth century; e.g. at Orchard Lane (Oakey 1997) and along Hartford Road (Connor 1996 and Welsh 1994), however, the large area of land encompassed by the town ditch was probably not completely filled with structures, even at the town's height. Thus, a location such as this which was peripheral to the settlement, and lay outside of its recognised limits, is unlikely to have experienced development. Except the straggling buildings that appear to have extended northwards along the old line of Ermine Street (present in the post-medieval period, but also suggested by the presence of the probable St Peter's and St Michael's church sites) no suburban sprawl has been identified in medieval Huntingdon. If this were to have existed then it may have congregated around the roads into town. The old line of Stone Field Lane runs adjacent to the western limit of the site. This must have been provided with a bridge/ford over the town ditch as it continued as Corbet's Lane, Stoney Lane or Fryers Lane, depending on the map/source.

3.3.3 The site lies in an area of land between the town ditch and the Priory precincts, adjacent to a minor medieval road and fording point and on the edge of Ambury Hill. None of these facts implies great certainty of medieval settlement, however, all taken together imply the slight possibility of medieval activity; perhaps of a satellite and temporary nature rather than definite occupation.

### 3.4 Post-Medieval

3.4.1 Cartographic and excavated data (for the latter, e.g. Connor 1996, Oakey 1997 and Roberts forthcoming) suggest a very major contraction of Huntingdon in the late medieval period. This ties in with the documentary sources which emphasise the poverty of the town following a particularly severe experience of plague, and economic eclipse by St Ives and other centres further downstream (Page, Proby and Ladds 1932). Occupation remains were not, therefore, expected on this site.



## **4 METHODOLOGY**

Prior to the commencement of fieldwork the AFU conducted a desktop review of the development area including a review of historical data, previous archaeological work and an examination of all available SMR entries, some of which has been presented in the previous sections.

- 4.1** A series of seven trenches totalling 90m in length were excavated using a JCB with a toothless ditching bucket. Trenches 1, 6 and 7 were located within the car park in the southern and eastern parts of the site. Trenches 2, 4, and 5 were wholly located within the new building footprint in the northern and eastern parts of the development site. A total of 5% of the development area was evaluated. All trenches were machined to the first terrace gravels. The locations of the trenches are shown in Figure 1.
- 4.2** After machining was completed each trench (except Trench 7) was cleaned by hand and photographed and recorded using the AFU standard archaeological recording system.
- 4.3** In addition all of the spoil heaps from the trenches were scanned for artefact retrieval.
- 4.4** Environmental samples were taken from many of the archaeological features in trench 1 and trench 6.

## **5 RESULTS**

Trenches 1, 2 and 6 revealed features which may be cuts from medieval earthfast timbers in the southern and eastern part of the development site. Trench 4 displayed evidence of quarrying or pitting and earlier features which may be prehistoric, including a trench for a palisade. Trenches 3, 5 and 7 contained no archaeological features although, due to waterlogging, the latter was not properly assessed.

Common layers were found in each of the excavated trenches which probably represent redundant cultivation soils (Figure 1 for trench locations).

### **5.1 Trench 1 (Figure 2)**

Trench 1 was 12m long and 0.90m deep and positioned on an approximate north-south alignment. It was located in order to investigate the area of the car park to the north of the proposed line of the town ditch. Layer 1 was composed of hard core material for the car park. Directly below layer 1 was an agricultural soil (layer 2) which was a dark grey brown sandy silty clay. This layer was 0.60m deep and contained a number of post-medieval artefacts. Below layer 2 were a number of features including postholes and beamslots.



Trench 1

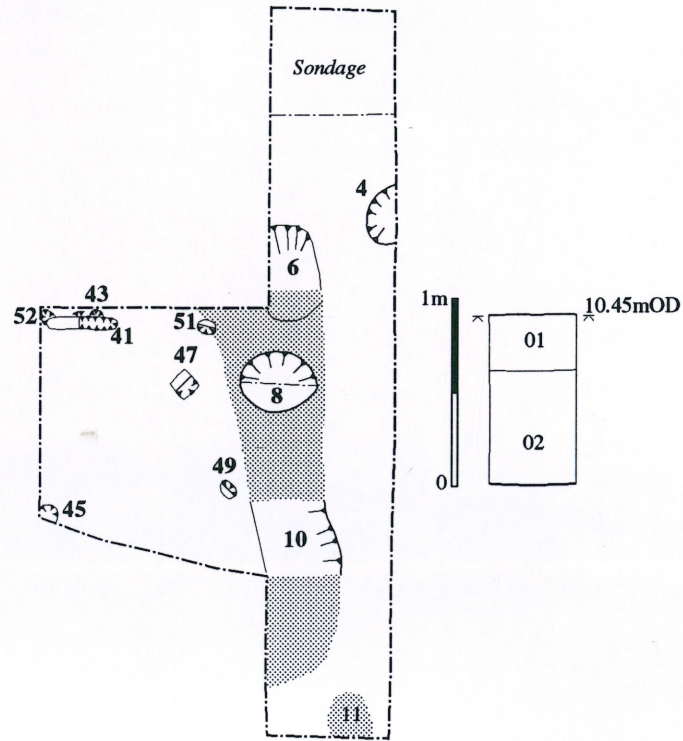

Trench 4

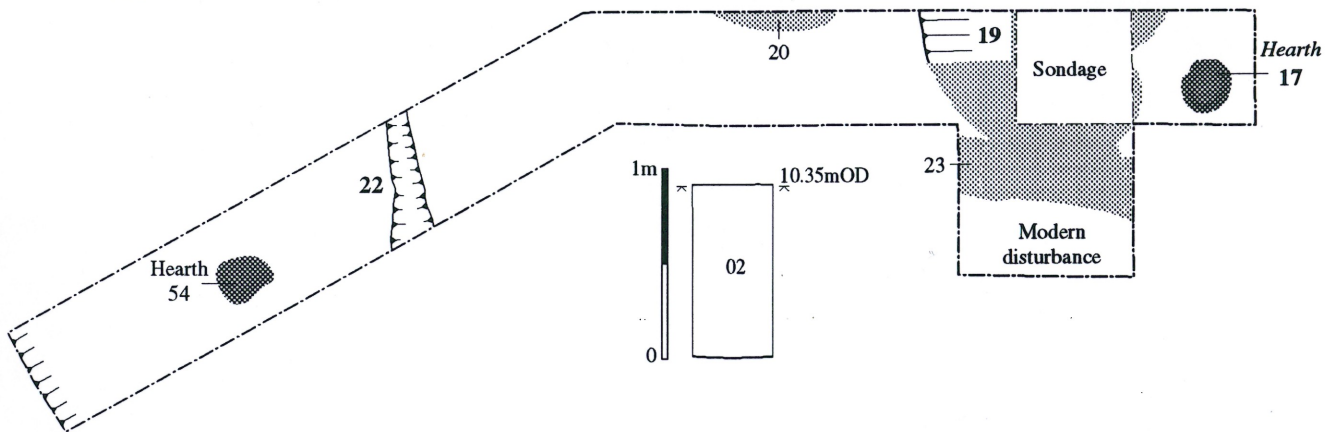

Trench 6

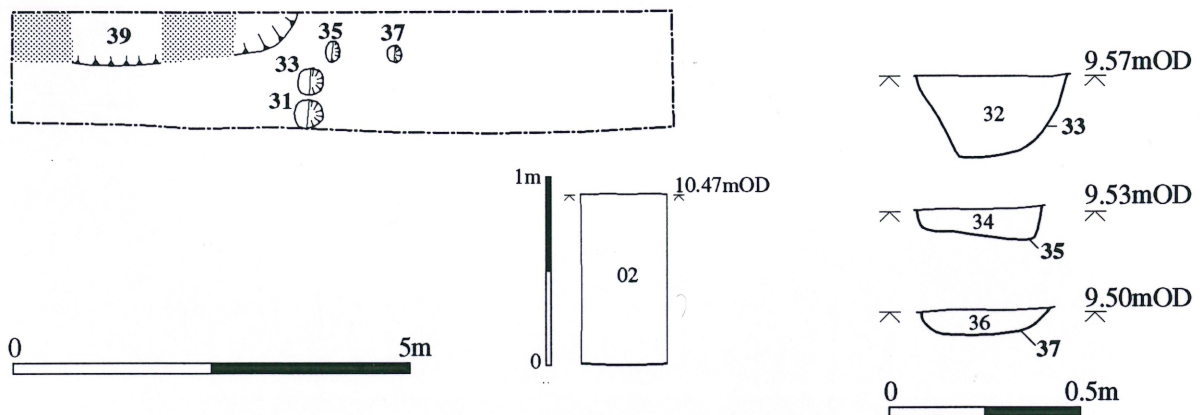

Figure 2 Plans of Trenches 1, 4 and 6 with representative schematic sections and key Trench 6 feature sections



Posthole 4, circular in plan, was 0.60m wide and 0.30m deep and contained one fill. The fill 3 was a soft, dark greyish brown silty clay with occasional sub-rounded stones which produced sherds dating from 1000-1150AD. To the west of this feature was a linear 10, 5m long and a 1m wide. It contained one fill 9 which was composed of a greyish brown silty clay with occasional small stones. This linear was cut by a posthole 6 at the northern end. Posthole hole 6 was 0.67 m wide and 0.45m deep and contained one fill 5. Fill 5, a greyish brown silty clay with lenses of sand, contained several sherds dating from 1000-1150AD.

Cut 8 truncated linear 10 and may represent a circular posthole 0.95m wide and 0.25m deep. The single fill 9 was a dark greyish brown silty clay with occasional sub-rounded stones.

Within the south western extension of the trench a group of features including postholes and a beamslot were identified. Posthole 45 was revealed in the south western corner of the trench, 0.30m wide and 0.18m deep and containing a single greyish brown silty clay fill. To the north of this feature a beamslot 41 cut two postholes 43 and 52. This stratigraphic sequence shows that there were at least two phases to this group of features.

To the south-east of these features a rectangular posthole 47 was revealed which was 0.45m wide and 0.11m deep and contained one fill 46. Fill 46 was composed of a greyish brown silty clay with occasional small gravel. Posthole 51 cut linear 10 and was 0.45m wide and 0.10m deep. It contained a silty clay fill. Posthole 11 was encountered in the southern end of the trench. It was 0.70m wide and produced pottery dating from 1100-1350AD but was not fully excavated.

## **5.2 Trench 2**

Trench 2 was 10 m long and 0.75m deep and was positioned on a north-south alignment in the western part of the development site. Linear 14 was 7m long, 0.39m wide and 0.07m deep. This linear consisted of one fill 13 which was composed of a sandy silty clay with occasional small angular stones. This feature was heavily truncated and as a result it is difficult to determine whether it was a ditch or a beam slot.

## **5.3 Trench 3**

Trench 3 was 8.80m long and 0.98m deep and was located on an east-west alignment in the northern part of the development site. No archaeological features were present in this trench.

## **5.4 Trench 4 (Figure2)**

Trench 4 was 19m long and 0.85 m deep and positioned on an east-west alignment in the northern part of the development site. In the eastern end of the trench were a group of intercutting features which may represent quarrying or pitting.



Pit **19** was circular, 1.80m wide and 1m deep. This feature contained one fill 18, which consisted of a silty clay with occasional small gravel. Pit 23 was unexcavated, 1.8m wide and contained a greyish brown silty clay.

To the east of this complex a probable hearth or bonfire base **17** was uncovered, 0.90m wide and 0.10m deep. The fill 16 was composed of a silty sandy clay with a moderate amount of charcoal. This feature may represent the base of a hearth, or alternatively it may have been a temporary fire. No dating evidence was recovered from this feature.

Another hearth or bonfire base **54** was identified in the western part of the trench. This was 0.90m wide but was not excavated. In the centre of the trench a ditch was encountered. Ditch **22**, running on a north-south alignment, had a V-shaped profile and was 0.40m deep and 0.40m wide. This ditch contained one fill which was a silty sand with occasional gravel. The profile of this ditch suggests that this may have been a construction trench for a wooden palisade. No artefacts were recovered from this feature.

#### **5.5 Trench 5**

Trench 5 was 19.70m long and 0.85m deep and was located in the eastern part of the site on a north-south axis. No archaeological features were encountered in this trench.

#### **5.6 Trench 6 (Figure 2)**

Trench 6 was 8m long and 0.90m deep and was located in the western part of the development site. A number of postholes were revealed which may form part of a timber building.

Posthole **31** was 0.35m wide and 0.14m deep, with a U-shaped profile. It contained one fill 30, a silty clay and with occasional small gravel, and produced one sherd dating between 1000 and 1200AD. Posthole **33** was 0.40m wide and 0.23m deep. It contained a fill 32 which was a greyish brown clay silt, and produced a number of St Neots ware sherds dating between 1000AD and 1200AD. Posthole **35** was 0.30m wide and 0.08m deep. It contained one fill 34, which was a greyish brown clay silt with occasional sub rounded stones. Posthole **37** was circular in plan and was 0.40m wide and 0.08m deep. It contained one fill which was composed of a greyish brown clay silt.

Linear **39**, which ran on a east-west alignment and was 3.60m long and 0.50m wide, contained one fill. This fill 38 was composed of a greyish brown silty clay and produced a number of St Neots ware sherds dating between 1000 and 1200AD.

#### **5.7 Trench 7**

Trench 7 was 8m long and 0.85m deep and situated on a north-south axis in the southern part of the development site.

Due to the waterlogging of this trench, no archaeological features were recorded here.



## **6 DISCUSSION**

### **6.1 Trench 1**

Despite the proximity of trench 1 to the medieval town ditch, it was surprising that significant remains of medieval activity were encountered because previous observations had suggested this side of the medieval town was not heavily occupied away from the main streets. The remains took the form of post holes, running on an approximately east-west and north-south alignment, forming a possible building. The evidence seems to suggest that there were at least two phases of structural activity, the earliest of which is represented by postholes **43** and **52** which pre-date beamslot **41**. Likewise the stratigraphy to the east of beamslot **41** shows there were at least two phases of construction with postholes **6** and **8** cutting linear **10**. It is difficult to ascertain the function of linear **10**, it could represent a large beam slot for a structure, or a former property boundary. Material culture recovered from these features suggests we are dealing with structures dating from 1100-1350 AD. On a wider level these earthfast features probably form part of a general zone of medieval buildings in the southern part of the development site.

### **6.2 Trench 2**

Linear **5** probably represents a beamslot or a truncated property boundary of twelfth to thirteenth century date. The lack of other evidence for buildings in this part of the site may suggest that this is more likely to be the remains of a boundary rather than a building.

### **6.3 Trench 3**

No archaeological features were encountered within this trench.





### **6.4 Trench 4**

In the eastern part of the trench a group of intercutting features may represent 12th or 13th century quarrying. This interpretation would then provide us with a fairly typical pattern for an urban medieval landscape with buildings fronting onto a route way with quarrying located to the rear of the buildings. The small number of artefacts recovered from Pit **18** tends to lend weight to the quarrying interpretation. Furthermore, the natural sand and gravels into which the quarry pits were cut suggest these deposits were being intentionally extracted.

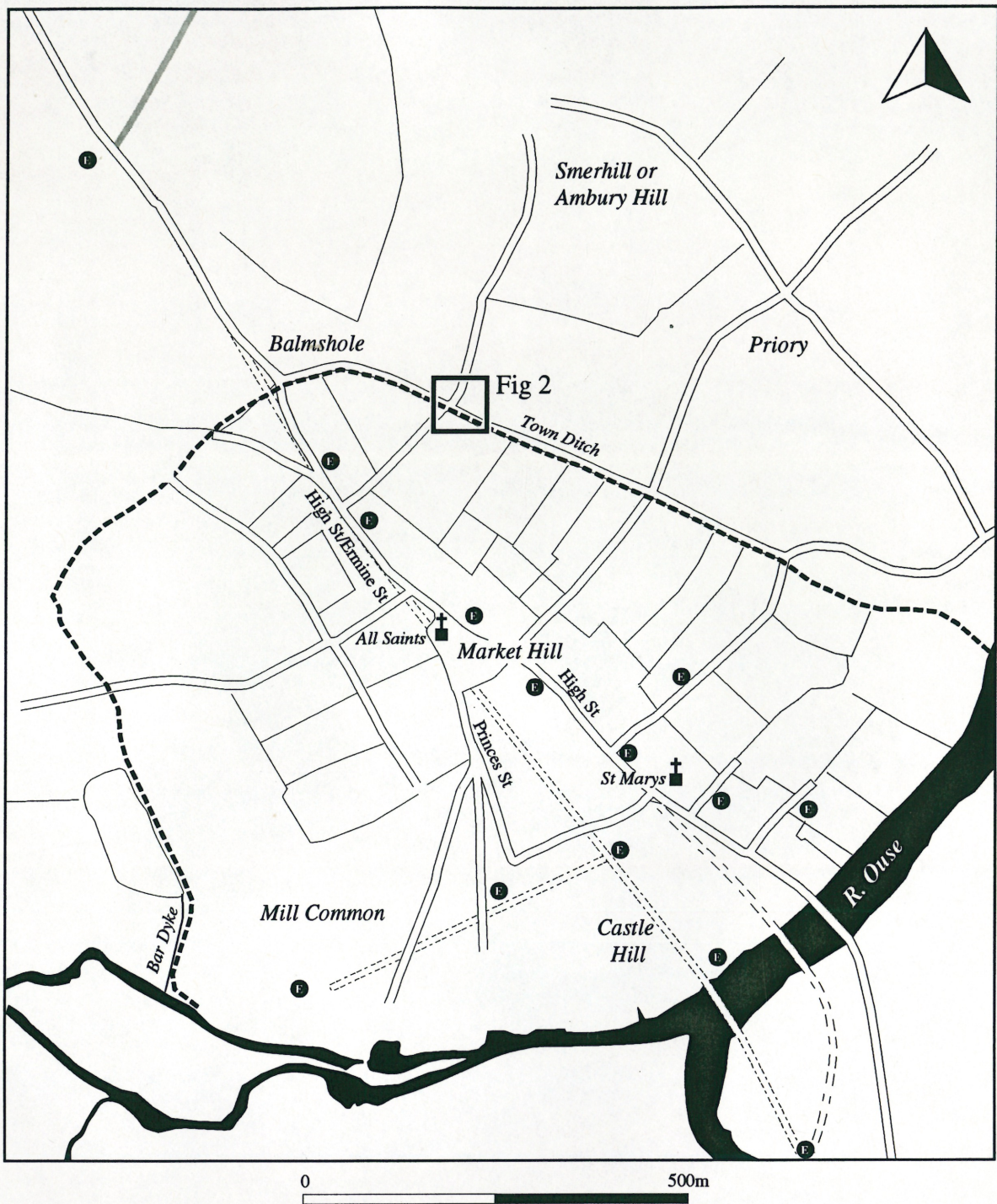
A palisade trench, bonfire hearths and an unexcavated pit with a similar fill, may represent prehistoric features. The palisade trench, running on north-south alignment, produced no artefactual evidence however, on the basis of the composition of its fill, it is very similar to features encountered another prehistoric sites within this section of the Ouse Valley system, e.g. Huntingdon Racecourse (Macaulay forthcoming).





-  Medieval town defences
-  Roman roads
-  Course of Old Bridge St
-  Surviving Medieval churches
-  Archaeological excavations

**Figure 3** Map of medieval Huntingdon showing course of defences, surviving churches and archaeological excavations



## **6.5 Trench 5**

No archaeological features were encountered in this trench.

## **6.6 Trench 6**

Postholes encountered in this trench may represent a building which is part of the general zone of buildings in the southern part of the development site. Material recovered from postholes **33** and **35** suggests the building dates from 1000-1200 AD. Linear **39** was difficult to interpret since it ran into the section but it probably represents a property boundary or a beamslot foundation.

## **6.7 Trench 7**

No archaeological features were encountered in this trench.

## **7 CONCLUSION**

The uncovering of medieval structures in the southern part of the site has demonstrated the wealth of archaeological evidence available to be recorded in an area immediately outside of the town ditch. The results have shown that the southern end of the development site is characterised by a zone of buildings, while at the northern end of the site there is evidence of earlier prehistoric activity and medieval quarrying.

Prior to this evaluation it was thought that the subject site was peripheral to the settlement, being outside of its recognised limits, and therefore was unlikely to have experienced development. However, the evidence suggests that we have medieval development outside the line of the town ditch. This finding is of considerable importance since it represents suburban development focused around a crossing point over town ditch, where the track to Abbots Ripton crossed it. The presence of frontage structures along the track on the outside of the ditch was unexpected. This is significant as the only other possible suburban development recognised through excavation is along the primary route Ermine St, to the north of the town (Mortimer 1996).

An alternative explanation could be that the remains encountered may represent buildings on the edge of the precinct of Huntingdon Priory which lies 200m to the north of the subject site.

Another possibility is that these buildings may in be inside the line of the town ditch. This would imply that much of the cartographic evidence is simplistic and that the actual line of the town ditch is different from that depicted on Speed's and Jeffery's maps. The actual line of the town ditch has never been confirmed through excavation which only underlines the problems in constructing a model for the development of medieval Huntingdon.

The possible prehistoric phase of the site is not wholly unexpected when it is considered that the subject site is located within the Ouse Valley which is generally rich in Neolithic and Bronze remains. The palisade-type feature may represent some form of landscape boundary. The interpretation of this



feature, which has a distinctive sand component in its fill, is hampered by the lack of dating evidence. The Bonfire/Hearths revealed in trench 4 were undated and may represent prehistoric features. Only further excavation will aid us in understanding their character and date.

## 8 ACKNOWLEDGEMENTS

The authors wish to thank the Clients, CCC Resources Directorate Property and Contract Services and Andrew Thomas from the CAO for monitoring the site work. Thanks are also extended to Nick Armour and Chris Montague for their work on site and Jon Cane for his illustrations.

## 9 BIBLIOGRAPHY

- Dickinson, G, M, 1972, *Survey of Huntingdon, 1572*, CCC, Huntingdon.
- Connor, A, 1996 *Early Medieval Structural Remains at 12 Hartford Road Huntingdon*, Cambridgeshire County Council AFU Report No122.
- Hart, C, 1966 The Church of St Mary of Huntingdon, *Proc.Camb. Ant. Soc.Vol LIX*, p105-111.
- Hinman, M & Kenney, S, 1998 *Prehistoric and Romano-British Remains Adjacent to Cow Lane, Godmanchester*, Cambridgeshire County Council AFU Report No150.
- Macaulay, S, forthcoming, *Neolithic and Bronze Age Ritual Landscape at Huntingdon Race Course*.
- Mahany, C and Burchard, A, 1982, *Excavations in Stamford, Lincolnshire 1963-69*, the Society for Medieval Archaeology Monograph No 9.
- Malim, T and Mitchell, D, 1993, *Neolithic ditches and Iron Age Settlement at Thrapston Road, Brampton, Cambridgeshire*, Cambridgeshire County Council AFU Report No81.
- Mortimer, R, 1996 *An Archaeological Assessment At Stanton Butts, Stukeley*, Cambridge Archaeological Unit Report 192.
- Page,W, Proby, G, and Ladds I, 1932, *The Victoria History of the County of Huntingdon*.
- Roberts, J, forthcoming *St Clements Passage, Huntingdon*, Cambridgeshire County Council AFU Report.
- Spoerry, P, forthcoming, 'The Topography of Medieval Huntingdon: Part 1, Anglo-Saxon' in *Proc.Camb. Ant. Soc.*
- Oakey, N and Spoerry, P, 1997. 'Excavations at Orchard Lane, Huntingdon', *Proc.Cam. Ant.Soc.* Volume LXXXV, 123-158.
- Welsh, K, 1994, *Medieval and Later Deposits at Marshall's Garage, High Street, Huntingdon*, Cambridgeshire County Council AFU Report No105.

### Maps consulted

Speed's 1610 map of Huntingdon consulted at Fulbourn  
Jeffrey's 1768 map of Huntingdon consulted at Fulbourn



## 8 APPENDIX A

### Pottery Spot dating

Context list	Material	Date
03	3 sherds of St Neots ware, cooking pot	1000-1150 AD
05	4 sherds of Shelly ware (Northants)	1000-1150AD
07	1 sherd hard sandy ware, (Northants)	1350-1500 AD
07	1 sherd of Shelly ware	1100-1350 AD
07	1 sherd of Thetfordware	1000-1200AD
07	9 sherds of St Neots ware	1000-1350 AD
11	1 sherd of Shelly ware	1100-1350 AD
14	1 sherd of Shelly wares	1150-1450AD
18	1 Essex Micaceous ware	1150-1350AD
18	4 St Neots ware	1000-1200AD
30	1 St Neots ware	1000-1200AD
32	1 Roman sherd	
32	1 St Neots ware	1000-1200AD
36	7 St Neots ware	1000-1200AD
38	5 St Neots ware	1000-1200AD
38	1 sherd of Ipswich ware	700-850AD
52	1 Shelly ware	1000-1350AD
54	1 Shelly ware Ely ware	1150-1350AD

### POTTERY ASSESSMENT

Paul Spoerry B Tech Phd

The main component of the assemblage is shelly pottery, both St Neots type ware and developed a form commonly called Shelly ware the latter deriving from Northamptonshire. The second most common type are general sandy wares.

The assemblage is of unremarkable types, probably domestic and has experienced secondary abrasion or reworking.

The lack of decorated glazed types of the 13th century implies most groups are a little earlier in date.



**HUNTINGDON, BROOKSIDE 1998 - Finds Types By Context (in grammes and by count)**

Site Locations		Ceramics				Metals				Lithics	Organics		Totals
Trench/ Location	Context Number	Pottery	Pottery Sherds	Tile & Brick	Metals Fe	Metals Cu	Metals Pb/Ag	Worked Stone	Animal Bone	Shell	Total Weights by Context		
Tr 1	u/s	277	27	128	33		113		203	3	757		
Tr 6	u/s	65	5						103		168		
Tr 7	u?s								18		17		
Tr 1	3	5	1						37		5		
Tr 1	5	18	5		33				7		312		
Tr 1	7	113	13		8	1		224			129		
Tr 1	11	6	1						1		6		
Tr 2	14	20	2						24		21		
Tr 4	18	25	6						2		49		
Tr 6	30	3	2						3		5		
Tr 6	36	82	11						34		85		
Tr 6	38	92	7						17		126		
Tr 1	46	4	1								17		
Tr 1	52	7	1								4		
Tr 1	54										7		
<b>Total Weights by Finds Type</b>		<b>717</b>	<b>82</b>	<b>128</b>	<b>74</b>	<b>1</b>	<b>113</b>	<b>224</b>	<b>449</b>	<b>3</b>	<b>1709</b>		

*Cambridgeshire County Council - Archaeological Field Unit*