

CAMBRIDGE  
ARCHAEOLOGY  
FIELD GROUP

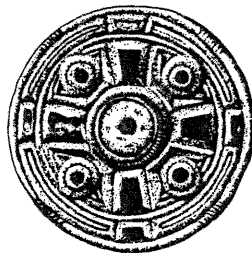

Archaeological Field Unit

**Medieval Settlement Remains  
at  
Cloverfield Drive, Soham**

Andrew Hatton & Stephen Macaulay

December 1999

**Cambridgeshire County Council**

Report No. 168

*Commissioned by Wilcon Homes Ltd*

**Medieval Settlement Remains  
at  
Cloverfield Drive, Soham**

Andrew Hatton HND, BSc  
Stephen Macaulay BA(Hons), MPhil, AIFA

December 1999

Editor Dr Paul Spoerry & Tim Malim  
Illustrator Jon Cane



*Report No. 168*

©Archaeological Field Unit  
Cambridgeshire County Council  
Fulbourn Community Centre  
Haggis Gap, Fulbourn  
Cambridgeshire CB1 5HD  
Tel (01223) 881614  
Fax (01223) 880946

Arch.Field.Unit@libraries.camcnty.gov.uk  
<http://www.camcnty.gov.uk/library/afu/index.htm>

## *Summary*

*Between the 25th October and 7th December 1999 an archaeological evaluation was undertaken on 12.5 hectares of land immediately to the northwest of the modern village of Soham (TL 5870/7420), by staff of the Cambridgeshire County Council Archaeological Field Unit. The work was carried out in connection with a proposed development of the site involving the construction of dwellings, access roads and services.*

*Thirteen trenches were excavated across the site to ascertain the presence or absence of archaeological remains. The subsequent investigation of the trenches revealed archaeological remains in all but two trenches (Tr. 7 & 11), consisting of postholes, pits and linear ditches. Many of the features contained pottery, dating to the period between 1150-1550 AD with the majority being Medieval Ely Ware. Some Roman pottery was recovered and other significant artefacts included fragments of animal bone. Evidence for possible Prehistoric structures was found at the north end of Trench 1 and also in Trenches 3, 4 and 11.*

*Many of the features identified on the higher ground, in Trenches 1 & 2, may be associated with structures, drainage ditches and field boundaries. The density of features suggests that these possible structures may have formed part of a linear development moving away from the centre of Soham, possibly linked to the Soham Mere fisheries. There are fewer features in the remaining trenches and the majority of these are ditches. They can probably be interpreted as field boundaries.*

## **LIST OF CONTENTS**

<b>1</b>	<b>INTRODUCTION</b>	<b>1</b>
<b>2</b>	<b>GEOLOGY &amp; TOPOGRAPHY</b>	<b>1</b>
<b>3</b>	<b>ARCHAEOLOGICAL &amp; HISTORICAL BACKGROUND</b>	<b>1</b>
<b>4</b>	<b>METHODOLOGY</b>	<b>5</b>
<b>5</b>	<b>RESULTS</b>	<b>6</b>
<b>6</b>	<b>DISCUSSION</b>	<b>17</b>
<b>7</b>	<b>CONCLUSIONS</b>	<b>19</b>
	<b>ACKNOWLEDGEMENTS</b>	<b>20</b>
	<b>REFERENCES</b>	<b>20</b>
	<b>APPENDIX A - POTTERY REPORT</b>	<b>21</b>

## **LIST OF FIGURES**

<b>Figure 1 - Site Location Plan</b>	<b>2</b>
<b>Figure 2 - Location of Trenches</b>	<b>3</b>
<b>Figure 3 - Detail Plan of Trenches 1 &amp; 2</b>	<b>8</b>
<b>Figure 4 - Sections</b>	<b>9</b>

# **Medieval Settlement Remains at Cloverfield Drive, Soham: An Archaeological Evaluation**

## **1 INTRODUCTION**

Between 25th October and 7th December, an archaeological evaluation was undertaken on 12.5 hectares of land immediately to the northwest of the modern village of Soham (TL 5870/7420), by staff of the Cambridgeshire County Council Archaeology Unit. The project was commissioned by Wilcon Homes Ltd in advance of a proposed residential development. The work was carried out according to a brief for archaeological evaluation issued by Cambridgeshire County Council County Archaeology Office (Thomas 1999). The work was supervised on site by Andrew Hatton and the project was managed by Stephen Macaulay.

## **2 GEOLOGY AND TOPOGRAPHY**

Soham is situated on a peninsular of slightly higher land (Bedfordshire Lower Chalk and 3rd Terrace Gravels) which projects northwest into the fens (10m+ OD) from Fordham. The site is on the boundary of the 3rd Terrace Gravels and the Gault Clay, which lies to the northwest of Soham at the 5m contour. The development area is covered, in part, by alluvium, which in turn seals the 3rd Terrace gravels.

## **3 ARCHAEOLOGICAL AND HISTORICAL BACKGROUND**

The SMR maps and records show no archaeological remains within and immediately adjacent to the proposed development area. Indeed there is no recorded find within 500m of the development area. Those that do exist (Cloverfield Drive, Soham, An archaeological Desktop Study, AFU Report A149, Fig. 2) lie mostly to the southeast, within Soham Village itself and further to the south and east. Further remains lie to the north, with the complex of Prehistoric sites associated with Broad Hill (Hall 1996) and to the west on the Wicken side of Soham Mere. Close to Wicken a number of Prehistoric and Roman sites have been recorded on the sands. Medieval ridge and furrow was recorded on the site in the 1940s but is not now evident.

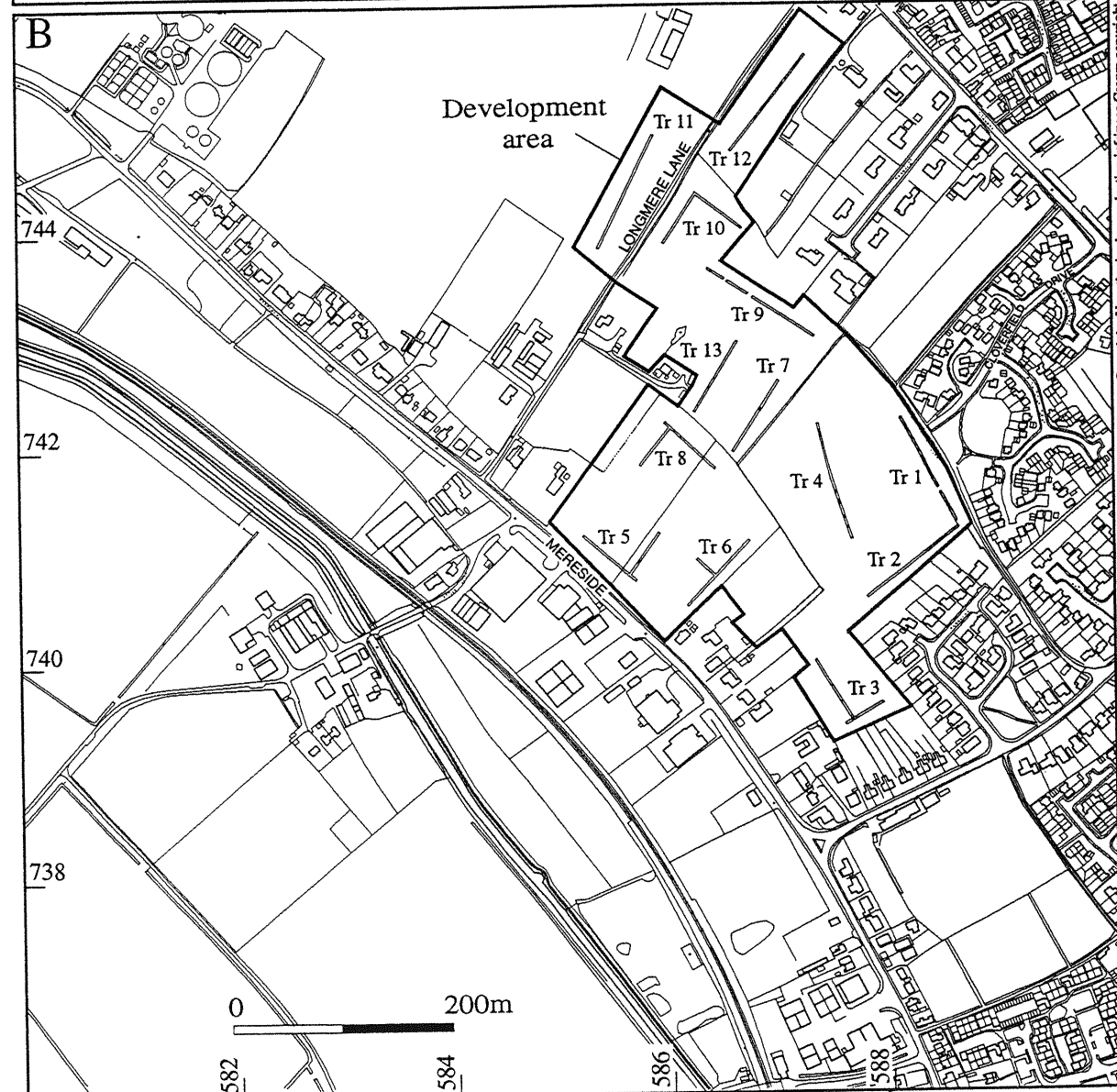
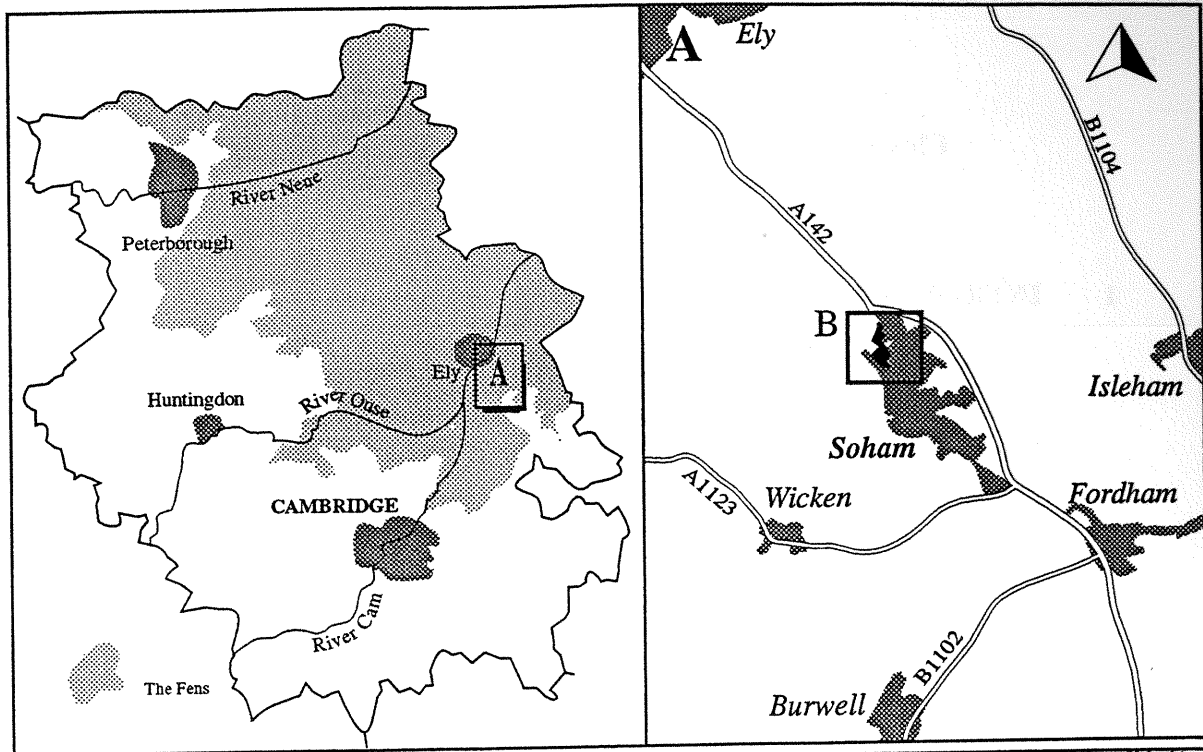

Based upon Ordnance Survey mapping with the permission of the Controller of Her Majesty's Stationary Office Crown Copyright. Unauthorised reproduction infringes Crown copyright and may lead to prosecution or civil proceedings. (Cambridgeshire County Council licence No. LA 07649X 1999)

Figure 1 Site Location Plan

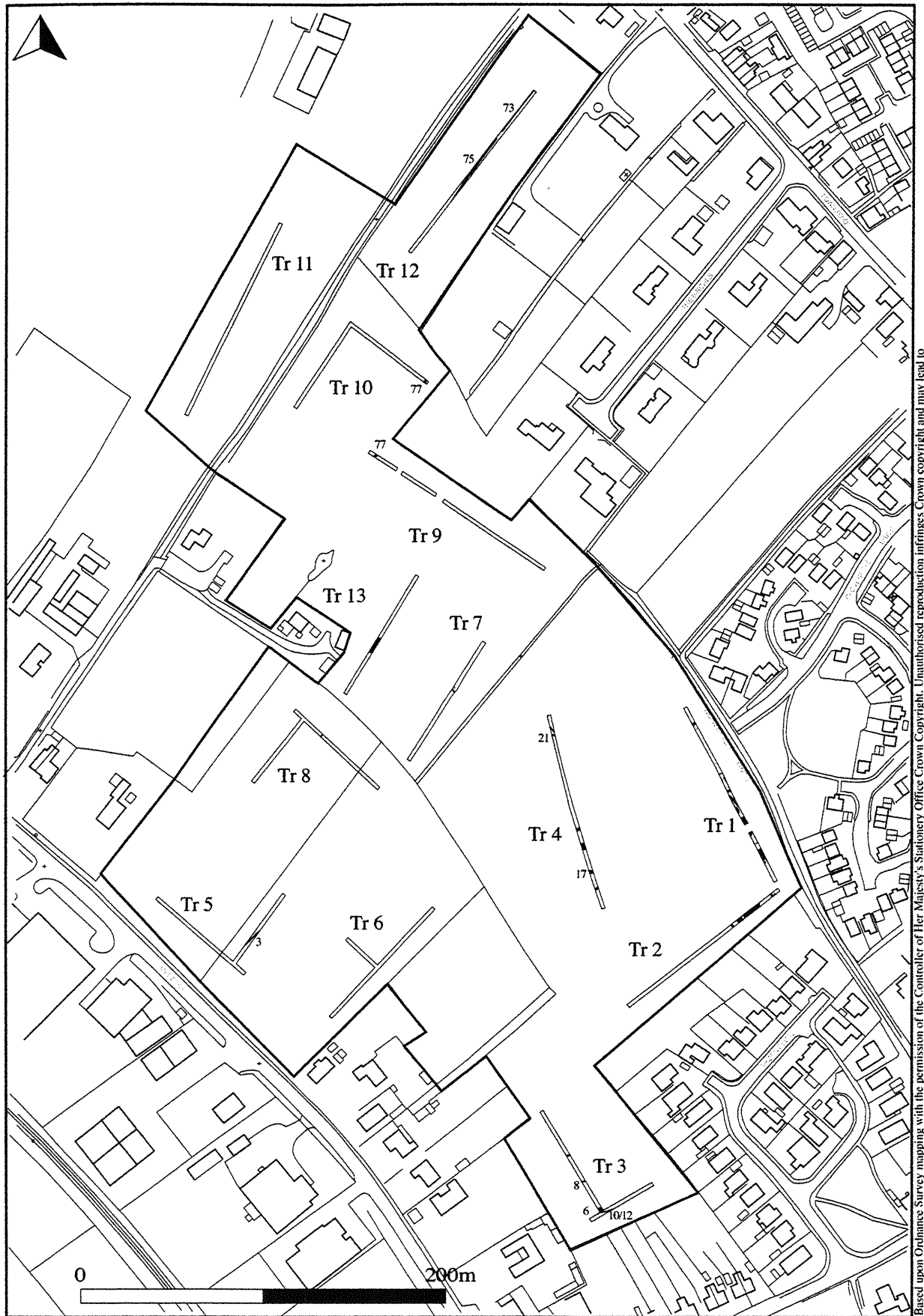

Based upon Ordnance Survey mapping with the permission of the Controller of Her Majesty's Stationery Office Crown Copyright. Unauthorised reproduction infringes Crown copyright and may lead to prosecution or civil proceedings. (Cambridgeshire County Council licence No. LA 07649X 1999)

**Figure 2** Location of trenches; archaeological features are shown in black. (Cut numbers referred to in the text are shown for trenches other than 1 and 2 which are detailed in Figure 3)

## **Prehistoric**

The Fen-edge around Soham, and the nearby Snail valley, have a long history of human activity (Hall 1996: 72-81). Prehistoric finds in the vicinity include Mesolithic tranchet axes (Cambs SMR 07077, 07098), Neolithic flint and polished axes (SMR 11019) as well as Bronze Age artefacts (SMR 07101, 11019a) and potential ring-ditches (SMR 07102). The Fenland Survey (Hall 1996) records most Prehistoric remains have been recovered from the Greensands to the north and west of Soham, extending from Fordham/Isleham and drift sands to the east. To the north of the site Hall records the Board Hill complex, which contains Neolithic, Bronze Age, Iron Age and Roman remains on the fen edge. To the west of Soham Mere, close to Wicken and Padney, a number of Neolithic and Bronze Age sites and artefact scatters have been identified on the lighter sandy soils (SMR 07037, 07039, 07040, 07041, 07044, 07061, 07061a, 07482, 09230).

## **Roman**

The area around Soham (and Wicken) contains a number of Roman sites which the Fenland Survey suggest indicate intensive fen-edge activity, perhaps attracted by the proximity of the River Cam and nearby crossing point at Fordey (Hall 1996). Roman burials are known within Soham (SMR 07086, 07100), although the majority of Roman sites are located to the south and south-east of the village, towards a possible Villa site. These Roman features are located on the lighter soils at Soham, Wicken and Padney, dating generally to the 2nd-4th century; the accepted date for increased Romanisation in the fens. Cropmarks on the sands have indicated enclosures and trackways.

## **Medieval**

There is a striking concentration of early Anglo-Saxon activity which includes a number of cemetery sites in and around the core of Soham. One of these appears to have lain in the vicinity of St Andrew's Church (SMR 07123a). Other burial sites have been discovered southeast of the village (SMR 07027) and along Fordham Road, which might have been the remains of a ploughed-out barrow (Lethbridge 1933). Pagan Anglo-Saxon barrows are rare in Cambridgeshire, although one was excavated last century in Bottisham (Taylor 1981:113). From Angle Common, to the west of the village, Anglo-Saxon spearheads have been recovered (SMR 07093, 07094). These, however date to the Late Saxon period (10th century) and may not be associated with a burial site.

The early historical significance of Soham is attested mainly by the foundation of a monastery in the 7th century AD by St Felix, first bishop of the East Angles, who was buried here (VCH II, 141). Although the site of this is not known, it is generally believed to have lain where the medieval church now stands.

Soham appears to have been at the centre of the See for a short while until it was relocated to Dunwich (SMR 7124). In the area around White Hart Lane the



remains of human burials have been recorded, potentially part of a major burial ground belonging to the abbey during the 7th to 9th centuries (Robinson 1995). The monastery was subsequently destroyed, along with the many other religious foundations in the area, during the late 9th century Danish invasions of East Anglia. Unlike nearby Ely, it was not re-established during the 10th century round of local refoundations (VCH II, 142). The manor of Soham, in fact, was among those given to the abbey at Ely, shortly after the latter's refoundation, by the earldorman Brithnoth (Conybeare 1897, 71). By the time of Domesday, the Abbot of Ely held 1/2 hide of land in Soham (VCH I, 364) but the manor was largely a royal estate, held by William I as it had been by Edward the Confessor.

The Fenland Survey states that there is no settlement activity away from village cores of Soham and Wicken (Hall 1996:79). This appears to be confirmed at Soham by results of an archaeological evaluation in the grounds of Soham County Primary School (Bray 1991), immediately east of the later excavation at Pratt Street (Hatton & Last 1997). Both sites, located close to the medieval church, identified pits, postholes and ditches containing animal bone, fired clay (remains of wattle walling) and pottery, dating to the 10th-13th centuries.

### **Post-medieval**

The fields around Soham were not enclosed and persist today as a remnant of the medieval field pattern. In North Field a few single-acre strips still survive today. There a number of windmills (SMR 06945, 07095) and pumps for the drainage channels recorded (SMR 06947, 06948, 06949). Soham Mere was not drained until the 19th century.

### **Soham Mere**

Finally, Soham Mere must be considered. Marine flooding, which deposited 'fen clay' occurred mainly in the 3rd millennium BC. This marine phase was followed by extensive peat growth, with a whitish shell marl forming possibly in the Roman period. The Mere survived as an expanse of water until drained in the 19th century, David Hall suggests that the marls will be of medieval or later date (Hall 1996:72) and may be encountered in the land around the 19th century extent of the mere.

## **4 METHODOLOGY**

Reassessment of air photographic evidence for the site was undertaken by Air Photo Services of Cambridge in order identify archaeological features prior to the field evaluation. Photographs examined at the Cambridge University Collection of Aerial Photographs showed the land under pasture with ridge and furrow visible as earthworks. A full report on the aerial photographic assessment is available in the site archive (Palmer 1999).

A desk-based assessment of known archaeological information for the site was undertaken before fieldwork began. This revealed general information about the area, rather than specific information about the site itself. The results of this study appear above as part of the archaeological and historical background.

Eleven 100m x 2m and 2 x 75m trenches were excavated using a mechanical excavator with toothless ditching bucket. The trenches were located across the area of the proposed development in order to obtain maximum coverage thus increasing the possibility of discovering any archaeological features. The lack of previous data regarding archaeology of any period in the immediate vicinity precluded the targeting of trenching to meet specific research aims. Research aims that could be determined were to; (a) investigate the edge of the gravel 'island'; (b) locate dispersed settlement evidence; (c) locate Mere-side activity; and (d) provide a sample of the development area.

The modern ground surface and subsoil were removed to a depth where the natural gravel or clay deposits were noted, between 0.40m and 0.90m below the present ground surface. Where potential features were encountered a process of cleaning and excavation took place followed by planning where appropriate. Trench spoil and the excavated surfaces of trenches were scanned by eye in order to obtain artefacts.

Archaeological trenches and features were recorded using a Zeiss RecElta 15 Total Station, and a digital base plan of the site was produced with Pro-surveyor mapping software. Archaeological features were sample excavated and recorded using the pro-forma recording sheets of the Archaeological Field Unit. All trenches excavated during the evaluation were described; giving details of topsoil and subsoil depths and the natural geology visible in the base of the trench.

## 5 RESULTS

### Trench 1 (see fig 3)

Trench 1 was 100m long and had to be split into two segments to avoid a drainage ditch which was filled in with modern debris. Orientation of the trench was north-west/south-east. At the north-western end of the trench, a brownish grey silty topsoil 0.30m thick overlay a brown silty clay subsoil 0.28m thick. This sequence was seen at the south-eastern end, although the topsoil thickness had increased to 0.35m and the subsoil had decreased to 0.23m thick. The natural geology observed in the two segments consisted of a light sandy brown clay interspersed with spreads of gravel.

A large number of features (pits, ditches and postholes) were identified cutting into the natural geology. Of the features identified a number were excavated, providing a good cross section of all feature types, with no feature type left unsampled.

Cut 26 (fig 4), 1.05m wide, 0.32m deep, linear ditch in plan, with almost vertical sides, orientation north-east/south-west, truncates 28 and 31, contained two fills:

**Fill 25**, a pale brownish-orange (slightly mottled) silty sandy soil, contained six sherds of Medieval Ely Ware pottery (hard fired, buff finish) 1300-1500 AD.

**Fill 24**, subsoil filling in the depression at the top of the feature, contained fifteen sherds of Medieval Ely Ware pottery which includes one fragment of a rounded bowl rim, and three fragments of either lid/curfew or warming plates (Dated to 1200-1400 AD)..

Cut 28 (fig 4), 0.50m wide, 0.45m deep, oval in plan, truncated by 26, contained one fill:

**Fill 27**, a mid orange-brown silty sandy soil, containing seven sherds of Medieval Ely Ware pottery (hard fired, buff finish), AD 1300-1500. The assemblage included one fragment of a short flanged rim.

Cut 31 (fig 4), 0.85m wide, 0.90m deep, oval in plan, truncated by 26, contained two fills:

**Fill 30**, basal fill, a mid orange-brown silty sandy soil, contained eighth sherds of Medieval Ely Ware pottery, AD 1300-1400. The assemblage included one fragment of short flanged rim that can be associated to a cookpot, one fragment of a jug rim (hard fired, buff finish) and also one fragment of Mill Green Fine ware.

**Fill 29**, a pale very orange-brown silty sandy soil, contained four sherds of Medieval Ely Ware pottery, AD 1200-1400. The assemblage contained one fragment of a warming plate or curfew.

Cut 33, 0.47m wide, 0.19m deep, sub-circular in plan, contained one fill:

**Fill 32**, a pale grey-brown silty sandy soil, contained no artefactual remains.

Cut 35, 0.38m in length, 0.32m wide, 0.11m deep, circular in plan, contained one fill:

**Fill 34**, a mid dark-brown silty sandy soil, contained no artefactual remains

Cut 37, 0.35m wide, 0.19m deep, circular in plan, contained one fill:

**Fill 36**, a mid greyish-brown silty sandy soil, contained no artefactual remains.

Cut 40, 0.21m wide, 0.16m deep, circular in plan, contained two fills:

**Fill 39**, 0.21m wide, 0.11m deep, a pale blue-grey clay, contained no artefactual remains. The position of the soil suggests that its primary function was for packing around a post.

**Fill 38**, 0.10m wide, 0.16m deep, a dark brownish-grey sandy silty soil, contained no artefactual remains. The fill indicates the position of a small post setting.

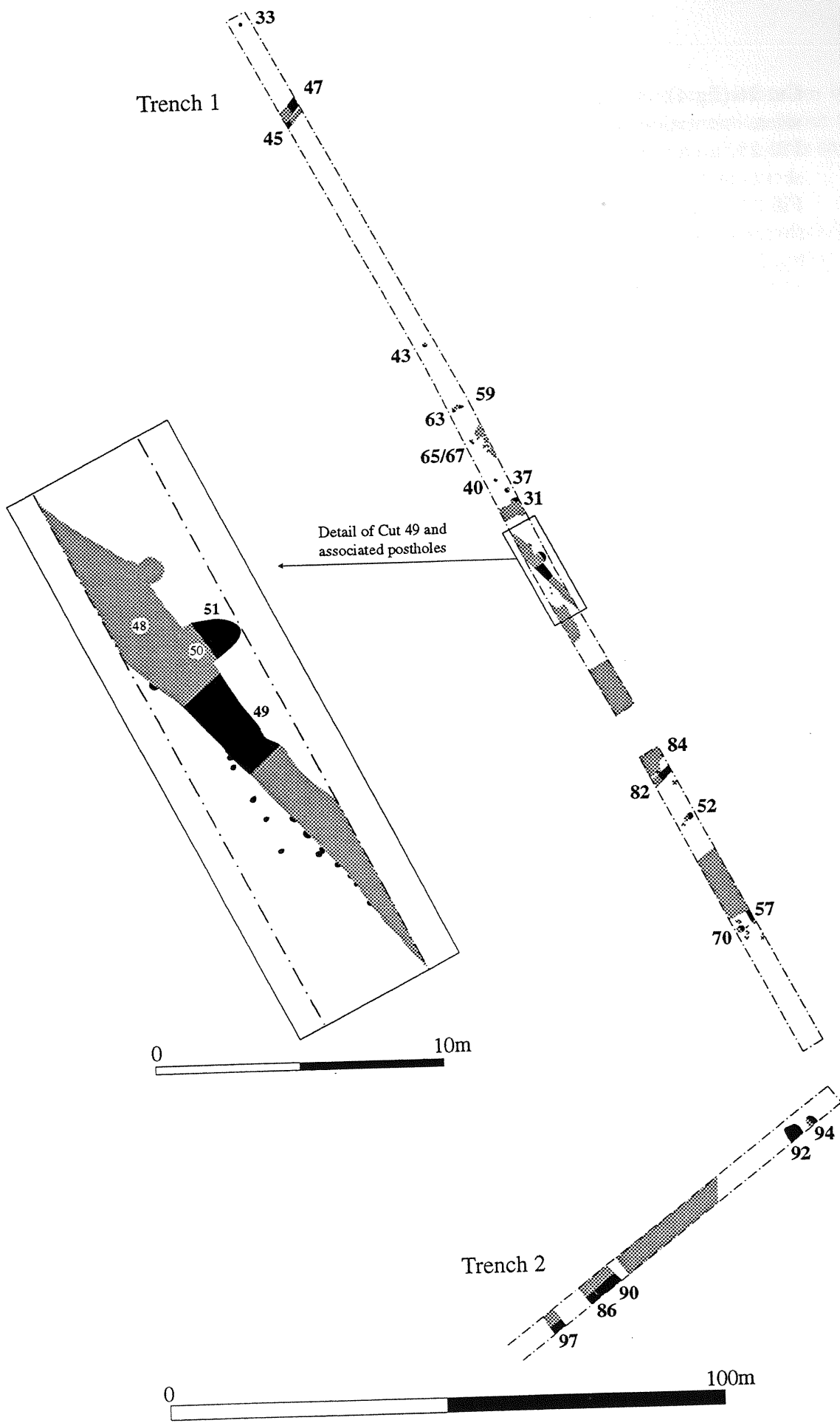
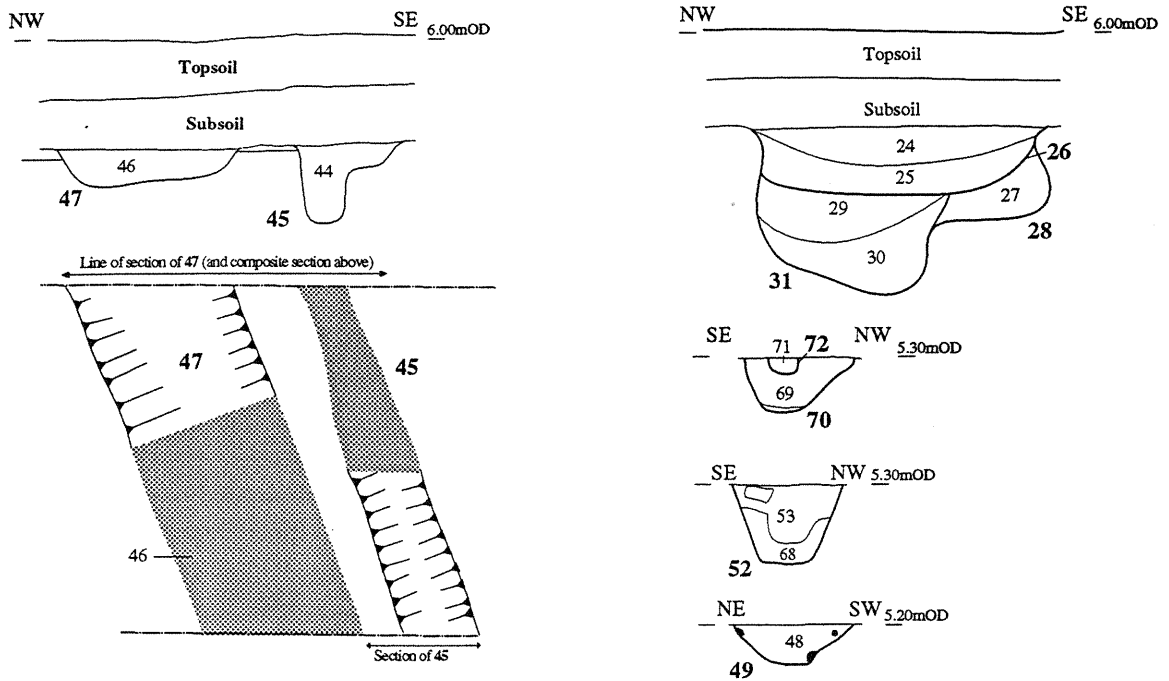
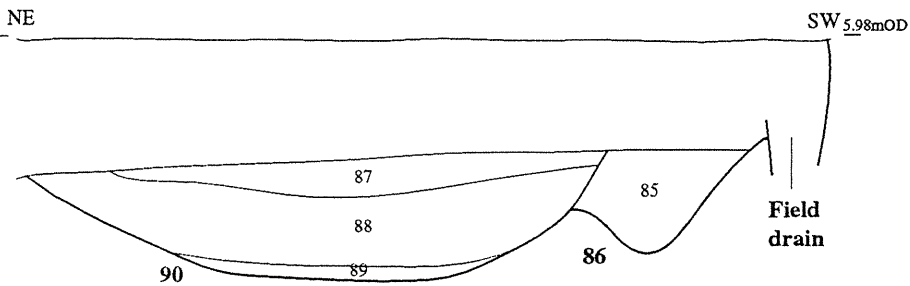

Figure 3 Detail of archaeological features in Trenches 1 and 2

Trench 1



Trench 2



Trench 3

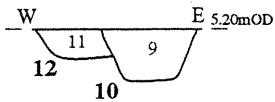

Trench 4

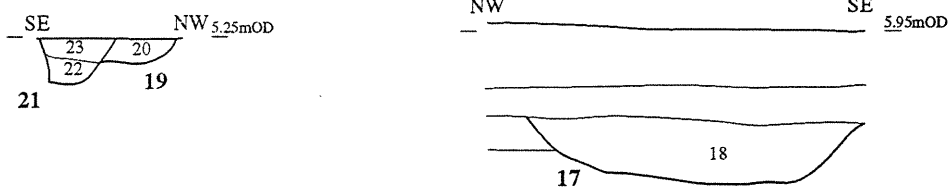

Trench 5



Figure 4 Sections

Cut 43, 0.42m in length, 0.37m wide, 0.22m deep, sub-circular in plan, contained two fills:

Fill 42, a dark brownish-grey silty sandy soil, contained no artefactual remains. Fill of original post setting.

Fill 41, Fill 42, a dark brownish-grey silty sandy soil, contained no artefactual remains.

Cut 45 (fig 4), 0.50m wide, 0.40m deep, narrow linear in plan, contained one fill:

Fill 44, a mid grey-brown, slightly mottled silty sandy soil, contained no artefactual remains.

Cut 47 (fig 4), 0.85m wide, 0.20m deep, linear in plan, contained one fill:

Fill 46, a pale yellowish-brown sandy soil, contained no artefactual remains.

Cuts 45 and 47 (Fig 4) are related in function forming a fence and boundary line.

Cut 49 (figs 3 & 4), 0.68m wide, 0.23m deep, linear in plan, contained one fill:

Fill 48, a light brown slightly mottled silty clay soil, contained no artefactual remains.

Cut 49 (fig 3), along its western side run a line of stakeholes which formed a fence.

Cut 51, 0.87m wide, 0.10m deep, oval in plan, contained one fill:

Fill 50, a light yellowish-brown sandy silty clay soil, contained one sherd of Medieval Ely Ware pottery 1300-1400 AD.

Cut 52 (fig 4), 0.65m wide, 0.47m deep, circular in plan, contained two fills:

Fill 53, a dark brown sandy silty soil, contained fourteen sherds of Medieval Ely Ware pottery 1200-1450 AD. The assemblage included angled bowl rims, one of which has been decorated with wavy lines. The fill indicates the position of a large post setting.

Fill 68, 0.53m wide, 0.33m deep, a light brown silty sandy soil, contained one sherd of Medieval Ely Ware pottery 1200-400 AD and a number of animal bone fragments. The fragment of pottery is from the rim of a large jar.

Cut 55, 0.60m wide, 0.15m deep, oval in plan, contained one fill:

Fill 54, a darkish brown sandy silty clay soil, contained three sherds of Medieval Ely Ware pottery 1200-1400 AD and a number of animal bone fragments.

Cut 57, 0.30m wide, 0.35m deep, linear in plan, contained one fill:

Fill 56, a light grey silty clay sand, contained nine sherds of Medieval Ely Ware pottery 1200-1400 AD. The assemblage contained one fragment of a jug which has been decorated with wavy lines.

Cut 59, 0.38m wide, 0.60m deep, oval in plan, contained one fill:

Fill 58, a light brown sandy silty clay soil, contained no artefactual remains.

Cut 61, 0.21m wide, 0.06m deep, circular in plan, contained one fill:  
**Fill 60**, a light brown clayey silty sandy soil, contained no artefactual remains.  
This feature could be interpreted as a shallow posthole.

Cut 63, 0.25m wide, 0.07m deep, circular in plan, contained one fill:  
**Fill 62**, a light brown clayey silty sandy soil, contained no artefactual remains.  
This feature could be interpreted as a shallow posthole.

Cut 65, 0.20m wide, 0.07m deep, oval in plan, contained one fill:  
**Fill 64**, a light brown clayey silty sandy soil, contained no artefactual remains.  
This feature could be interpreted as a shallow posthole.

Cut 67, 0.10m wide, 0.05m deep, oval in plan, contained one fill:  
**Fill 66**, a light brown clayey silty sandy soil, contained no artefactual remains.  
This feature could be interpreted as a shallow posthole.

Cut 70 (fig 4), 0.58m wide, 0.28m deep, sub-square in plan, contained one fill:  
**Fill 69**, a light brown clay silty sandy soil, contained no artefactual remains. This feature could be interpreted as a posthole.

Cut 72 (fig 4), 0.14m wide, 0.10m deep, circular in plan, contained one fill:  
**Fill 71**, a very dark grey clayey silty sandy soil, contained no artefactual remains.  
This feature could be interpreted as a posthole.

Cut 80, 0.20m wide, 0.17m deep, linear in plan (rounded butt-end), contained one fill:  
**Fill 79**, a dark greyish-brown slightly mottled silty sandy soil, contained no artefactual remains.

Cut 82, 0.60m wide, 0.22m deep, linear in plan, contained one fill:  
**Fill 81**, a pale greyish-brown silty sandy soil, contained no artefactual remains.

Cut 84, 0.90m wide, 0.22m deep, irregular in plan, contained on fill:  
**Fill 83**, a dark grey-brown silty sandy soil, contained six sherds of Medieval Ely Ware pottery which includes two fragments of rounded bowl rims (from different vessels), also a large fragment of lava quern. The context dates to 1200-1450 AD.

## **Trench 2**

Trench 2 was 100m long and ran south-west/north-east. At the south-western end of the trench, a brownish grey silty clay topsoil 0.30m thick overlay a brown sandy clay subsoil 0.20m thick. This sequence remained the same at the north-eastern end although the depth of topsoil decreased to 0.28m while the subsoil remained 0.20m thick. The base of the trench consisted of light brown sandy clay natural geology which included small spreads of gravel. The natural geology

observed in the base of the trench consisted of light brown and grey clay, interspersed with gravel spreads.

A number of features were identified cutting into the natural geology, of which the following were sampled.

Cut 86 (fig 4), 0.70m wide, 0.50m deep, linear in plan, contained one fill:

**Fill 85**, a mid brownish-grey silty sandy soil, contained a fragment of industrial brick c. 19th century.

Cut 90 (fig 4), 2.9m wide, 0.60m deep, linear in plan, contained three fills:

**Fill 89**, 1.7m wide, 0.08m deep, basal fill, a very dark brownish-grey sandy silty soil, contained two sherds of post medieval pottery 1600-1800 AD.

**Fill 88**, 2.9m wide, 0.54m deep, main infill, a mid brownish-grey slightly mottled silty sandy soil, contained one sherd of post medieval pottery 1600-1800 AD.

**Fill 87**, 2.4m wide, 0.2m deep, a mid greyish-brown silty sandy soil, contained two sherds of Roman buff sandy ware pottery (c2nd-4th C AD), although these are likely to have been residually deposited from the plough soil above.

Cut 92, 1.32m wide, 0.86m deep, rectangular in plan, contained one fill:

**Fill 91**, dark greyish-brown silty sandy soil with pale-brown mottles, contained two sherds of Medieval Ely Ware pottery 1200-1400 AD.

Cut 94, 0.66m wide, 0.40m deep, circular in plan, contained one fill:

**Fill 93**, a mid greyish-brown silty sandy soil, contained two sherds of Medieval Ely Ware pottery 1150-1400 AD.

Cut 97, 0.80m wide, 0.33m deep, linear in plan, contained two fills:

**Fill 95**, 0.80m wide, 0.33m deep, upper fill, a mid/light brown clay silt soil, contained no artefactual remains.

**Fill 96**, 0.45m wide, 0.09m deep, basal fill, a clay silty sandy soil, contained no artefactual remains.

Cut 99, 0.40m wide, 0.20m deep, narrow linear slot in plan, contained one fill:

**Fill 98**, a dark greyish brown silty clay soil, contained no artefactual remains.

**Fill 100**, 1.1m wide, 0.15m deep, a mid-brown silty clay soil that appears to infill the depression resulting from the uneven silting-up of [97 & 99].

Cuts 97 and 99 are related in function forming a fence and boundary line.

### Trench 3

Trench 3 was split into two segments and arranged in an L-shape, with the north-west/south-east segment measuring 60m and the north-east/south-west segment measuring 40m. At the south-western end of the trench, a brownish grey silty clay topsoil 0.25m thick overlay a brown sandy clay subsoil 0.35m thick. This sequence remained the same at the north-eastern end (which is also the north-western end of the 60m segment of the trench), although the topsoil depth



decreased to 0.28m and the subsoil also decreased to 0.27m. The north-eastern end of the trench saw the same sequence as previously described with the topsoil 0.35m thick and the subsoil 0.20m thick. The base of the trench consisted of a mixer of light brown and light grey clay, interspersed with small gravel spreads.

Trench 3 contained a number of features many of which were sampled.

Cut 6, 0.40m in diameter, 0.12m deep, circular in plan, contain one fill:

Fill 5, a light brown silty clay soil, contained no artefactual remains.

Cut 8, 0.85m wide, 0.13m deep, linear in plan, contained one fill:

Fill 7, a mid brown silty clay soil, contained no artefactual remains.

Cut 10 (fig 4), 0.50m wide, 0.27m deep, linear in plan, contained one fill:

Fill 9, a mid brown silty clay soil, contained no artefactual remains.

Cut 12 (fig 4), 0.35m wide, 0.16m deep, linear in plan, contained one fill:

Fill 11, a light brown silty clay soil, contained no artefactual remains.

Cut 16, 1.1m wide, 0.25m deep, linear in plan, contained three fills:

Fill 15, a mid brown silty clay soil, contained no artefactual remains.

Fill 14, basal fill, a brownish grey silty clay soil, contained no artefactual remains.

Fill 13, upper fill, a mid brown silty clay soil, contained no artefactual remains (although Roman pottery was recovered nearby during machining =u/s)

#### Trench 4

Trench 4 was 100m long and ran south-east/north-west. At the south-eastern end of the trench, a brownish grey silty clay topsoil 0.30m thick overlay a brown sandy clay subsoil 0.35m thick. This sequence remained the same at the north-western end although the depth of topsoil increased to 0.33m and the subsoil decreased to 0.30m thick. The base of the trench consisted of light brown sandy clay natural geology which included small spreads of gravel.

A total of five linear ditches and one linear gully was identified cutting into the natural geology. However on excavation of the linear gully was found to be a double ditch. Two of the linear features were sampled.

Cut 17 (fig 4), 1.8m wide, 0.38m deep, linear in plan, orientation north-east/south-west, contained one fill:

Fill 18, a mid brown sandy silt, contained no artefactual remains.

Cut 19 (fig 4), 0.40m wide, 0.14m deep, linear in plan, orientation south-west/north-east, contained one fill:

Fill 20, a mid brown sandy silt, contained no artefactual remains.

Cut 21 (fig 4), 0.40m wide, 0.24m deep, curvilinear in plan, orientation north-east/south-west, contained two fills: Cut 21 is a re-cut/re-setting of Cut 19.

Fill 22, 0.28m wide, 0.16m deep, a mid brown sandy silt, contained no artefactual remains.

Fill 23, 0.40m wide, 0.13m deep, a darkish brown sandy silt, contained no artefactual remains.

### **Trench 5**

Trench 5 was split into two segments and arranged in an L-shape, with the north-west/south-east segment measuring 60m and the north-east/south-west segment measuring 40m. At the south-western end of the trench, a brownish grey silty clay topsoil 0.30m thick overlay a brown sandy clay subsoil 0.17m thick. This sequence remained the same at the north-eastern end (which is also the north-western end of the 60m segment of the trench) although the depth of topsoil increased to 0.30m and the subsoil decreased to 0.25m. The north-eastern end of the trench saw the same sequence as previously described with the topsoil 0.30m thick and the subsoil 0.16m thick. The base of the trench consisted of a light grey clay natural geology.

One linear ditch was identified cutting into the natural geology which was sampled in two places.

Cut 1 (fig 4), 0.60m wide, 0.21m deep, linear in plan, orientation north-east/south-west, contained one fill:

Fill 2, light grey-brown silty clay, no artefacts were recovered from the fill.

Cut 3 (fig 4), .68m wide, 0.21m deep, linear in plan, orientation north-east/south-west, contained one fill:

Fill 4, light grey-brown silty clay, contained two fragments of Medieval Ely Ware 1200 - 1400 AD and one sherd of Late Medieval Orange Sandy Ware pottery 1350 - 1500 AD.

### **Trench 6**

Trench 6 consisted of two segments arranged in a T - shape with the longest segment 80m and the shortest 20m. At the north-eastern end of the trench, a brownish grey silty clay topsoil 0.30m thick overlay a brown silty clay subsoil 0.15m thick which in turn sealed a light brown/light grey clay natural which also included occasional gravel spreads. This sequence remained the same at the south-western end of the trench where the topsoil layer was 0.30m thick, and the subsoil layer increased to 0.18m thick, and sealed the same natural geology. At the north-western end of the 20m segment of the trench the topsoil was 0.30m thick, and this overlay a subsoil 0.10m thick. The sequence remained the same at the south-eastern end but the subsoil thickness increased to 0.22m. No archaeological features were identified in the trench.

### **Trench 7**

Trench 7 was 75m long and ran north-east/south-west. At the south-western end of the trench, a brownish grey silty clay topsoil 0.25m thick overlay a brown sandy clay subsoil 0.32m thick. This sequence remained the same at the north-eastern end although the topsoil increased to 0.33m and the subsoil decreased to 0.30m. No archaeological features were identified in the trench.

### **Trench 8**

Trench 8 was split into two segments and arranged in an L-shape, with the north-west/south-east segment measuring 60m and the north-east/south-west segment measuring 40m. At the south-western end of the trench, a brownish grey silty clay topsoil 0.25m thick overlay a brown sandy clay subsoil 0.15m thick. This sequence remained the same at the north-eastern end (which is also the north-western end of the 60m segment of the trench), although the topsoil increased to 0.30m and the subsoil decreased to 0.10m. The south-eastern end of the trench saw the same sequence as previously described with the topsoil 0.30m thick and the subsoil 0.16m thick. The base of the trench consisted of a light grey clay natural geology.

A total of three ditches were identified cutting into the natural geology, running at right-angles to the trench which on provisional investigation contained a mid-brown silty sandy soil, no artefactual remains were identified on the surface of each ditch. Before the features could be thoroughly investigated the trench flooded to such a depth as to remove the possibility of further excavation. However they exhibited the same deposit and feature profiles of other ditches identified in Trenches 4, 5, 9 and 10 and suggest a medieval date (1200-1550) and field boundary function.

### **Trench 9**

Trench 9 totalled 100m in length, having been split into three segments to avoid culvert drains, and was oriented north-west/south-east. At the north-western end of the trench, a brownish grey silty topsoil 0.30m thick overlay a brown silty clay subsoil 0.10m thick. This sequence was seen at the south-eastern end, although the topsoil thickness had decreased to 0.25m and the subsoil had increased to 0.20m thick. The natural geology observed in all three segments was light sandy brown clay.

A ditch was identified cutting into the natural geology at the north-western end of the trench which is on the same alignment as feature Cut 77 (see Trench 9 below), no artefactual material was recovered from this feature.

## Trench 10

Trench 10 consisted of two segments arranged in an L - shape, with each segment measuring 50m in length. At the south-western end of the trench, a brownish grey silty clay topsoil 0.25m thick overlay a brown sandy clay subsoil 0.15m thick. This sequence remained the same at the north-eastern end although the topsoil increased to 0.30m and the subsoil decreased to 0.15m. Observation of the south-eastern end of the trench found the same sequence as previously described with the topsoil being 0.40m thick and the subsoil 0.33m thick. The base of the trench consisted of a light brown silty sandy clay natural geology.

One linear ditch was identified cutting into the natural geology.

Cut 77, 1.15m wide, 0.26m deep, linear in plan, orientation north-east/south-west, contained one fill:

Fill 78, a mid brown sandy silt, contained no artefactual remains.

## Trench 11

Trench 5 was 100m long and ran approximately north-east/south-west. At the north-eastern end of the trench, a brownish grey silty clay topsoil 0.30m thick overlay a brown sandy clay subsoil 0.18m thick. This sequence remained the same at the south-western end although the topsoil decreased in thickness to 0.27m and the subsoil increased to 0.20m thick. The base of the trench consisted of a light brown clay together with patches of blue clay natural. No archaeological features were identified in the trench.

## Trench 12

Trench 12 was 100m long and ran approximately north-east/south-west. At the south-western end of the trench, a brownish grey silty clay topsoil 0.35m thick overlay a brown silty clay subsoil 0.20m thick which in turn sealed a blue and sandy clay natural which also includes occasional gravel spreads. This sequence remained the same at the north-eastern end of the trench where the topsoil layer in the sequence was 0.24m thick, below 0.10m of subsoil which sealed the same natural geology as identified at the south-western end of the trench.

Two linear ditches were identified cutting into the natural geology.

Cut 73, 0.74m wide, 0.10m deep, linear in plan, orientation north-east/south-west, contained one fill:

Fill 74, a mid grey-brown clayey silt soil, contained one fragment of tile waster of unknown date and place of origin.

Cut 75, 0.65m wide, 0.12m deep, linear in plan, orientation north-south, contained one fill:

Fill 76, a mid grey-brown clayey silt soil, contained one sherd of Medieval Ely Ware pottery 1200-1400 AD, and four sherds of Late Medieval Smooth Essex Red Ware pottery 1400-1550 AD.

Cut 73 and 75 are related and run on the same alignment, with an entrance identified within the trench.

### Trench 13

Trench 13 was 75m long and ran north-east/south-west. At the south-western end of the trench, a brownish grey silty clay topsoil 0.32m thick overlay a brown sandy clay subsoil 0.20m thick. This sequence remained the same at the north-eastern although the topsoil increased to 0.37m and the subsoil also increased to 0.30m. In the middle of the trench a large area of disturbance was identified and on investigation of the section was found to have been cut from immediately below the topsoil. The unusual shape of the feature in plan, and the height from which it was cut, indicate that it was a modern quarry pit excavated in order to remove sand and gravel.

## 6 DISCUSSION

The full nature of medieval and earlier occupation on the site cannot be fully determined from evaluation trenches, however the nature and perceived extent of the deposits encountered indicate that significant medieval occupation has been identified at Cloverfield Drive, Soham. Despite the lack of recorded finds in the Sites and Monuments Record, excavation of the exposed surfaces in the evaluation trenches revealed a significant number of archaeological features with a notable (and important) concentration in Trenches 1 & 2 (fig. 3). Trenches 3 through to 13 contained either a small number of archaeological features; ranging from the odd posthole and pit; to frequent ditches; or no feature at all (fig. 2).

The plan of Trenches 1 & 2 (fig. 3) raises a number of questions pertaining to the function of the features encountered and the relationship to other archaeological features encountered during excavations closer to the centre of Soham (see above). A high number of postholes were observed cutting in to the natural geology of Trench 1 that may be associated to either one or a number of dwellings and/or fences/boundaries. Many of the postholes excavated produced both pottery fragments and animal bone, the majority of the pottery was dated to 1200-1400 AD, and identified as Medieval Ely Ware, with the occasional sherd dated to 1550 AD. A number of ditches were identified and these produced pottery fragments which were dated to 1200-1400 AD. In addition fragments of animal bone were also recovered from the ditches excavated. Finally the nature of a number of fills, which contained charcoal, might suggest that occupation was in the vicinity. The most interesting segment of medieval ditch identified in Trench 1 was feature 49 (fig 4) which consisted of a linear ditch, with a number of stake or

small postholes postioned along the south-western edge, which could be interpreted as a fence line (fig. 3). A silted-up small quarry pit feature 31 was excavated in Trench 1 (fig 4) and produced sherds of pottery dated to 1200-1400 AD, including part of a 'curfew' or warming plate, plus fragments of animal bone. Feature 31 was found to have been cut by a later ditch feature 26, which also produced pottery that could be dated to 1400-1550 AD and part of another 'curfew' (fig. 4). This evidence suggests that medieval occupation is present.

A curvilinear ditch, feature 3, identified in Trench 5 was sampled and produced sherds of pottery which were dated to 1200-1500 AD, together with fragments of animal bone (fig. 2). To interpret the use of feature 3 within the landscape is somewhat problematic, because of the limited nature of the investigation at this stage, however a boundary or field enclosure ditch would seem the most likely function. Trench 12 was the only other trench where features (linear ditches) were encountered, these produced sherds of pottery which were dated to 1200-1400 AD. Both features 73 and 75 (Trench 12) were linear in plan, but also turn thus creating a corner which could possibly suggest that the features are enclosure ditches, dividing up the land nearest to the Ely/Soham road (fig. 2).

Most of the features excavated in Trenches 1 & 2 produced pottery fragments and animal bone, however two of the ditches 47 & 45 (fig. 4) and one posthole 33 located at the north-western end of Trench 1 produced no artefactual remains when excavated. The paucity of finds might be attributed to the antiquity of the features sampled (i.e. Prehistoric). Although it is impossible to say with any certainty that 45, 47 & 33 are contemporary, their proximity, combined with the lack of finds and the similarity in the nature of their deposits, implies this. Ditch/linear 45 was found on excavation to have steep sides and an almost flat base, and was interpreted by the excavators as a possible palisade trench (fig. 3 & 4).

Certain similarities may be drawn between Cuts 45 & 47 (fig 4) and linear ditches identified in Trenches 3 (Cuts 10 & 12), 4 (Cuts 19 & 21) and 10, a number of which were sampled and again produced no artefactual remains. The similarity does not end with the lack of artefacts within the excavated deposits, but also the shape in profile of both feature 10 (Trench 3) and feature 21 (Trench 4) each of which has reasonably steep sides and a flat bases, which could possibly be considered a form of foundation trench (fig, 4), for a palisade or fence. If these features are all broadly contemporary then there is a distinct possibility of a Prehistoric component to the site, possibly settlement.

In general Trenches 1 & 2 have more concentrated remains than seen elsewhere on the site and this appears to represent the difference between medieval settlement and its associated field systems. The ditches and odd postholes found in Trenches 3-13 (the land off the gravel terrace to the northwest, west and southwest) suggest that they do not represent settlement evidence, but rather that the land was agricultural and it does not contain dense archaeological deposits. In contrast to this the nature and density of features in Trenches 1 & 2 suggest that a medieval settlement is present. The position on slightly higher land, on the well drained gravels rather than the clays, made this a location to be preferred.

Trenches 7-11 and 13 do not contain the density or type of archaeological features representative of medieval settlement and thus indicate that the main bulk of archaeology is located to the east of the site around Trenches 1 & 2 with some continuation in trenches 3, 4 and 12.

## 7 CONCLUSION

The objectives of the project were to establish the character, date, state of preservation and extent of any archaeological remains within the site likely to be affected by ground disturbing development. This information was then to be used to allow an assessment to be made of the proposed development's archaeological implications and to inform an appropriate mitigation strategy. Detailed plans of the proposed development are not presently available, but if it involves the construction of houses, together with associated access roads and services, the potential impact on below-ground remains over the whole development area is likely to be extensive.

The project has been very successful in achieving its objectives. Archaeological remains were identified in all but two of the trenches (Trenches 7 & 11) suggesting that the area to be developed had been used as a place of human activity from at least the 12th century, with occupation evidence in both Trenches 1 & 2, while the limited number of features across the remainder of the development area may be attributed to its use for agricultural purposes. As noted above the density and nature of the remains identified have made it possible to make some predictive models. Although archaeological features have been identified across the majority of the area there is a clear concentration of deposits to the east (especially in Trenches 1 & 2) on the higher gravel terrace. Off this higher geology the nature and density of remains decreases although the possible occurrence of Prehistoric features in several trenches could indicate other settlement of earlier periods is present on the site and awaits clarification through further work. This land is likely to have been in agricultural use from the medieval period, with a settlement of medieval date (1200-1550) around Trenches 1 & 2. The discovery of such occupation is interesting given the distance from the known medieval core of the village of Soham, in an area of previously unknown archaeology. The reason for this settlement here may relate to the proximity of the medieval mere-side. A rural settlement site at East Kirkby in Lincolnshire has been linked to fish smoking from the presence of distinctive pieces of pottery curfews (Hall & Coles 1994, 136) and the presence of two of these very rare vessels in the small assemblage at Soham, plus the mere-side location, surely implies a similar interpretation for an otherwise unexplained settlement found at some distance from the main village.

## **ACKNOWLEDGEMENTS**

The author would like to thank Wilcon Homes (Anglia) Limited who commissioned and funded the work, and in particular Carl Atkinson their Senior Land Manager. The project was managed by Paul Sperry and Stephen Macaulay. Rebecca Cassa-Hatton and Tony Baker worked on site with the author and Scott Kenney carried out the site survey work. Jon Cane produced the illustrations.

The brief for archaeological work was written by Andy Thomas, who also visited the site and monitored the evaluation.

## **References**

Bray, S. (1991). **Medieval settlement at Pratt Street, Soham**. Cambs CC Arch. Field Unit Report No. 28.

### **Cambridgeshire Sites and Monuments Record (SMR).**

Coles, J and Hall, D. (1998). **Changing Landscapes: The Ancient Fenland**. Cambridgeshire County Council.

Darby, H.C. 1983. **The Changing Fenland**. University Press Cambridge..

Conybeare, E. (1897). **A History Of Cambridgeshire**

English Heritage (1997). **English Heritage Archaeology Division Research Agenda**. Draft.

Fox, C. (1923). **The Archaeology of the Cambridgeshire Region**. University Press Cambridge.

Glazebrook, J. ed (1997). **Research and Archaeology: a Framework for the Eastern Counties, 1. Resource assessment**. EAA Occ. Paper No. 3.

Hall, D. & Coles, J. (1994). **Fenland Survey**. English Heritage.

Hall, D. (1996). **The Fenland Project 10: Cambridgeshire Survey, the Isle of Ely and Wisbech**. EAA No. 79.

Hatton, B & J. Last. (1997). **Late Saxon Features at 9-13 Pratt Street, Soham: An Archaeological Evaluation**. Cambs CC Arch. Field Unit Report No. A107.

Heawood, R. (1997). **Late Saxon/Saxo-Norman Settlement Features at 38 Station Road, Soham: An Archaeological Investigation**. Cambs CC Arch. Field Unit Report No. 142.

Ravensdale, J.R. (1974). **Liable to Flood**. University Press Cambridge.

Taylor, C. (1973). **The Cambridgeshire Landscape**. Hodder & Stoughton.

Thomas, A. (1999). **Design Brief for an Archaeological Evaluation at Land North-West of Soham**. Cambridgeshire County Council County Archaeology Office May 1999.

Salzman, L.F. (ed) **Victoria County History of Cambridgeshire and the Isle of Ely. Volume I**

Salzman, L.F. (ed) **Victoria County History of Cambridgeshire and the Isle of Ely. Volume II**



## APPENDIX A - SOHCD99 Cloverfield Drive, Soham, Pottery Report by Dr Paul Spoerry

An assemblage of 93 sherds of pottery was recovered from evaluation trenching at Cloverfield Drive, Soham. The vast majority of this material is Ely ware, dating to the 13th or 14th centuries, and this includes some unusual forms including a possible curfew or warming plate and a curfew or lid with a loop handle. In addition some sherds of harder-fired late medieval Ely ware are also present (contexts 25 and 27). Other medieval pottery is all from Essex, including Mill Green fineware (1250-1400) and late medieval smooth redware (1400+). Some post-medieval and possible Roman sherds are also present.

The curfew/warming plate and curfew lid recovered from 24 and 29 are unusual forms, Coles & Hall reports that an increased presence of such items on a medieval site excavated in the Lincolnshire Fenland has been taken by the excavators to imply fish smoking (Hall & Coles 1994, 136). The closeness of the site to the important medieval fisheries on Soham Mere, may imply a similar interpretation here.

The remainder of this assemblage implies medieval domestic activity from the 13th to 15th centuries, with perhaps a few later features. The pottery is unabraded and in large fragments suggesting excellent survival *in situ* in negative features.

Context	Description	Total Wt.	Sherd Nos.	Context Date Range
4	MEL and OSW wares	40g	2 x MEL 1 x OSW	1350-1500
24	MEL wares (inc. round based rims, warming plate & handle=lid)	447g	15	1200-1400
25	MEL (hard fired buff fabrics)	76g	6	1300-1500
27	MEL wares (hardfired buff fabric).	220g	9	1300-1500
29	MEL ware (inc. warming plate?)	150g	4	1200-1400
30	MEL wares (jug rims & cook pots), Mill Green finewares.	178g	4 x MEL 1 x Mill Green	1300-1400
51	MEL wares	3g	1	1200-1400
53	MEL wares (wavy line decorated) with angled bowl rims (flat topped)	259g	14	1200-1450
54	MEL wares	39g	3	1200-1400
56	MEL wares	121g	9	1200-1400
68	MEL ware (inc. large jar rim)	80g	1	1200-1400
74	Unknown wares (waster or burnt)	9g	1	?
76	MEL sherd and Late Med. Smooth Essex Redwares	18g	1 x MEL 4 x Redware	1400-1550
83	MEL wares (inc. bases and rounded bowl rims)	189g	8	1200-1450
85	Early Industrial Brick	130g	1	19th Century
87	Roman sandy wares	16g	2	c2nd-4th C AD
88	PMR wares	12g	1	1600-1800
89	PMR wares	160g	2	1600-1800
91	MEL wares (jug with external wavy line decoration)	91g	2	1200-1400
93	MEL wares (calcareous soft fabric)	27g	2	1150-1400 (earlier?)
u/s	Roman sandy ware	19g	1	c2nd-4th C AD

MEL = Medieval Ely Wares

PMR = Post Medieval Redwares

OSW = Orange Sandy Wares