

Grace Manor Nursing Home
Grange Road
Gillingham
Kent



Archaeological Evaluation Report



Oxford Archaeology

February 2005

Client: Grace Manor Care Ltd

Issue N^o: 1

OA Job N^o: 2574

Planning Ref N^o: 2003/2746

NGR: TQ 7930 6847

Grace Manor Nursing Home, Grange Road, Gillingham, Kent

ARCHAEOLOGICAL EVALUATION REPORT

CONTENTS

Summary	1
1 Introduction	1
1.1 Scope of work.....	1
1.2 Location, geology and topography.....	1
1.3 Archaeological and historical background	1
2 Evaluation Aims	2
3 Evaluation Methodology	2
3.1 Scope of fieldwork	2
3.2 Fieldwork methods and recording.....	2
3.3 Finds	3
3.4 Palaeo-environmental evidence.....	3
3.5 Presentation of results.....	3
4 Results: General.....	3
4.1 Soils and ground conditions	3
4.2 Distribution of archaeological deposits	3
5 Results: Descriptions	3
5.1 Description of deposits.....	3
5.2 Finds	6
6 Discussion and Interpretation	6
6.1 Reliability of field investigation.....	6
6.2 Overall interpretation.....	6
Appendix 1 Archaeological Context Inventory.....	8
Appendix 2 Bibliography and References.....	10
Appendix 3 Summary of Site Details.....	10

LIST OF FIGURES

Fig. 1 Site location
Fig. 2 Trench location plan showing special relationships of archaeological features
Fig. 3 Trench 1, plan and sections 100-101
Fig. 4 Trench 2, plan and sections 200-201
Fig. 5 Trench 3, plan and sections 300-302
Fig. 6 Trench 4, plan and sections 400-402
Fig. 7 Trench 5, section 500-501

SUMMARY

Between the 18th and 19th January Oxford Archaeology (OA) carried out a field evaluation at Grace Manor Nursing Home, Grange Road, Gillingham, Kent (NGR: TQ 7930 6847) on behalf of Grace Manor Care Ltd. The evaluation revealed an extension of walls from the earlier excavations in area A dating to the 15th and 16th centuries. Structural remains were however, limited to the south-eastern corner of the site. The remaining area revealed a medieval ditch and post-medieval pits.

1 INTRODUCTION

1.1 Scope of work

1.1.1 Between 18th and 19th January 2005 OA carried out a field evaluation at Grace Manor Nursing Home, Grace Road, Gillingham, Kent (NGR:TQ 7930 6847) on behalf of Grace Manor Care Ltd. This was in respect of planning application for a new extension to an existing building (Planning Application No. 2003/2746). A brief was produced by the Heritage Conservation Group of Kent County Council (KCC 2004) setting out the requirements of the archaeological condition, and a WSI was produced by OA (OA, 2004) in line with the brief which was approved by KCC.

1.2 Location, geology and topography

1.2.1 The site is located east of Gillingham, 280 m south-west of the A289 and Lower Rainham Road roundabout at NGR: TQ 7930 6847 (Fig. 1). The development area is presently a garden to the south-west of Grace Manor, bounded to the south and west by agricultural land, to the north by gardens and to the east by buildings. The site lies at approximately 22 m OD and measures roughly 750 m². The underlying geology is Thanet Beds and Bullhead Beds.

1.3 Archaeological and historical background

1.3.1 The archaeological background to the evaluation has been the subject of a separate study produced for the WSI, the results of which are reproduced below.

1.3.2 The site itself has produced significant archaeological evidence notably remains associated with the former medieval Grench Manor, which originally stood on the site. There are known locations with archaeological remains adjacent to the development site.

1.3.3 Grace Manor Nursing Home stands on the former site of the medieval Grench Manor, which dates back to the 13th century. A small Grade II Listed medieval chapel dating to the mid to late 14th century just north of the site and the Refectory to the north-east are the only upstanding remains associated with the former manor.

1.3.4 Excavation work carried out in the 1990's by Archaeology South East (ASE 1996) immediately south-east of the proposed development area revealed three phases of construction spanning the 13th to 16th centuries. The foundations of a 15th century building were recorded extending westward into the proposed new development area.

While the excavation areas were limited it is believed a much larger medieval complex survives within the bounds of the site.

- 1.3.5 Fragments of Roman tile and a sherd from a Samian dish (Dressel. 36) were retrieved during a rescue excavation undertaken by Kent Archaeological Rescue Unit in 1992 within the site (KARU 1992) suggesting a Roman presence within the area. This is supported by finds such as the 3rd-4th century Roman coin hoard found approximately 200 m to the north-east of the site.

2 EVALUATION AIMS

- 2.1.1 To establish the presence or absence, extent, condition, nature, character, quality and date of archaeological remains within the proposal area. In particular, to establish further evidence of the medieval complex known to be present in the site.
- 2.1.2 To establish the ecofactual and environmental potential of archaeological deposits and features.
- 2.1.3 To make available the results of the investigation.

3 EVALUATION METHODOLOGY

3.1 Scope of fieldwork

- 3.1.1 The evaluation consisted of five 10 m long by 1.5 m wide trenches, totalling 50 m in length and forming a 10% sample of the development area (Fig.2).
- 3.1.2 Trench 1 was located within the north-east corner of the proposed buildings footprint, Trench 2 was initially located within the south-east corner of the footprint, however, this was moved 1.5 m to the south-east to avoid a soakaway pit. Trench 3 was located within the north-west corner of the footprint, Trench 4 was located centrally and Trench 5 was located within the south-west corner. All the trenches were aligned south-west to north-east bar Trench 5, which was aligned south-east by north-west.

3.2 Fieldwork methods and recording

- 3.2.1 The trenches were excavated under close archaeological supervision by a mechanical excavator (JCB) fitted with a 1.5 m wide toothless grading bucket. Excavation proceeded to the top of the first significant archaeological horizon or to the top of the natural geology, whichever was encountered first.
- 3.2.2 The trenches were cleaned by hand and any revealed features were sampled to determine their extent and nature, and where possible to retrieve finds and environmental samples. All features and deposits were issued with unique context numbers. Where significant archaeological features were present the trenches were planned at a scale of 1:20, otherwise at 1:50. Sections of excavated features and sample sections were drawn at a scale of 1:20. All features, sections and trenches were photographed using colour slide and black and white print film. Recording followed procedures laid down in the *OA Field Manual* (OAU 1992).

3.3 Finds

3.3.1 Finds were recovered by hand during the course of the excavation and bagged by context. Finds of special interest were given a unique small find number.

3.4 Palaeo-environmental evidence

3.4.1 No deposits suitable for paleo-environmental sampling were encountered during the course of the evaluation.

3.5 Presentation of results

3.5.1 The results of the evaluation are presented below starting with individual descriptions of each trench followed by an overall discussion. An inventory of all deposits and features recorded can be found in Appendix 1.

4 RESULTS: GENERAL

4.1 Soils and ground conditions

4.1.1 All trenches came down onto natural drift geology represented by a silty clay alluvium. All the soil divisions were clearly defined with little or no mixing between the contexts. Groundwater was not encountered within any of the trenches.

4.2 Distribution of archaeological deposits

4.2.1 The only significant archaeological remains, in the form of medieval walls, were encountered within Trench 2. The remainder of the trenches revealed marginal soils of post-medieval date onwards, or no archaeological features of unknown date.

5 RESULTS: DESCRIPTIONS

5.1 Description of deposits

Trench 1 (Fig. 3)

5.1.1 A natural, yellow-brown silty clay alluvium (102) was reached at a depth of 0.5 m below ground level. At the northern end of the trench this was cut by a “V” profiled ditch terminus 0.8 m wide by 0.3 m deep (103), representing a probable boundary ditch. This was filled by a light grey-brown silt clay (104), which produced no dating evidence. At the southern extent of the trench the natural was cut by a large flat based feature 2 m long by 0.3 m deep (105) filled by a 0.1 m thick layer of grey brown clay silt (107) and a 0.2 m thick layer of dark grey-brown silt loam (106). This represents the truncated base of a possible garden feature dated to the 19th century by pottery retrieved from its fill.

5.1.2 These were overlaid by a 0.35 m thick layer of yellow-brown clay silt made ground (101), probably deposited during the construction of the last phase of building

(1990's). The 0.3 m deep modern landscaping deposit of grey-brown silt loam (100) seals this.

Trench 2 (Fig. 4)

- 5.1.3 The natural yellow-brown silty clay alluvium (205), was reached at 0.6 m below current ground level. At the southern end of the trench this could be seen to be overlaid by a 0.14 m thick layer of dark yellow-brown clay silt (204), a layer of possibly medieval ploughsoil. Cutting into this layer were two foundation trenches, (207) and (209) containing walls 206 and 208 respectively. Wall 206 measured 0.5 m wide by 0.25 m deep and formed an "L" shape in plan, running in from the eastern edge of the trench and turning northwards for approximately 1.4 m before being truncated. Wall 208 measured 0.45 m wide but its depth was not fully exposed. This ran in from the eastern edge of the trench before turning and running out of the southern edge of the trench.
- 5.1.4 Both walls were built using Kentish ragstone and occasional flints bonded with a lime mortar. These were of similar construction, representing a contemporary phase of construction.
- 5.1.5 Towards the northern end of the trench the truncated remains of a 0.6 m wide wall (214) was observed overlying layer 204. This was also constructed from Kentish ragstone, occasional flints and tile fragments bonded with a lime mortar. The western end of this feature had been robbed out, while the eastern end had been truncated by the insertion of a later phase wall of (213). This later wall measured 0.4 m wide by over 2.6 m in length, and ran in from the eastern edge of the trench before its truncation, possibly by the same event that effected the remains of wall 206.
- 5.1.6 At the northern end of the trench a north-west to south-east aligned wall (215) was also recorded overlying layer 204. This measured 0.3 m wide by 1.6 m long and was constructed of Kentish ragstone and occasional flints bonded within a lime mortar. This wall along with wall 213 was of similar construction and alignment as 206 and 208 and is therefore likely to be from the same phase of construction.
- 5.1.7 Overlying the eastern edge of wall 213 was a 0.25 m deep layer of pale grey sandy silt (212), containing a high percentage of mortar inclusions and many small ragstone fragments. This probably represents a demolition layer associated with the robbing out of this wall. This was overlaid by a 0.22 m thick layer of dark grey-brown clay silt (211), possibly representing redeposited soil within a robber trench. Overlying the southern edge of deposit 211 and running off towards the south, was a 0.4 m deep layer of yellow brown clay sand (210). This contained numerous small to medium sized fragments of ragstone and representing a demolition layer. Sealing this deposit and running over the top of the robbed out wall 206, 208 and 215 was a 0.15 m thick layer of olive-brown clay silt (203). This contained many ragstone and tile fragments together with a high proportion of mortar flecking representing either another demolition or a levelling layer.

- 5.1.8 Layer 203 was then overlain by a 0.15 m thick layer of grey-brown clay silt garden soil (202), of probable 19th century date, which continued throughout the trench and was in turn sealed by a 0.25 m thick layer of dark grey-brown clay loam, representing the present day garden soil.

Trench 3 (Fig. 5)

- 5.1.9 The natural alluvium (304) was reached at a depth of 0.8 m below current ground level. Cut into the top of this layer was a 0.7 m wide round bottomed gully (308), up to 0.15 m deep. This was filled by a pale grey-brown clay silt (307), which produced a fragment of bone and roofing tile. Sealing this ditch and running the length of the trench was a 0.2 m thick layer of dark yellow-brown clay silt (303) which contained chalk and charcoal flecking and fragments of abraded ceramic building material and may represent a former medieval ploughsoil.
- 5.1.10 Cutting into layer 303 was the terminus of ditch (310), a 0.8 m wide round bottomed 0.2 m deep feature. Filled with a pale grey-brown clay silt (309) containing a fragment of earthenware pottery, this was a probable post-medieval boundary ditch. Also cutting layer 303 was the edge of steep sided, flat bottomed pit (306). Measuring 1.1 m wide by 0.6 m deep, this was filled by a grey brown clay silt which produced fragments of post-medieval tile.
- 5.1.11 Both fills of these features 306 and 310 were sealed by a 0.12 m thick layer of grey-brown silt loam (302), the same as layers 101 and 202 in Trenches 1 and 2. This was then sealed below a 0.3 m deep layer of 301, which produced modern glass and plastics.

Trench 4 (Fig. 6)

- 5.1.12 The natural alluvium (404) was reached at a depth of 0.8 m below current ground level. This was sealed by a 0.2 m thick layer of dark yellow-brown clay silt (403) which contained chalk and charcoal flecking as well as abraded ceramic building material representing a medieval ploughsoil 303 seen in Trench 3.
- 5.1.13 A circular flat bottomed rubbish pit (406) measuring 1 m diameter by 0.45 m deep and filled with a grey-brown clay silt (405) containing fragments of cast iron guttering and 19th century glass bottles was seen to cut the ploughsoil 403. At the northern end of the trench 403 was also cut by a steep sided flat bottomed ditch (408) measuring 0.7 m wide by 0.5 m deep. This was filled by a grey-brown clay silt (407) which produced charcoal flecking and abraded ceramic building material representing a possible post-medieval boundary ditch.
- 5.1.14 Sealing both 406 and 408 across the length of the trench was a 0.2 m thick layer of grey-brown silt loam (402). As in Trench 3, this represents the former topsoil in this area. This was overlaid by a layer of dark grey-brown silt loam 0.25 m to 0.4 m in depth (401), a layer of modern made ground composed of redeposited topsoil similar to 301.

Trench 5 (Fig. 4, sections 500 and 501)

5.1.15 The natural alluvium (504) was reached at a depth of 0.8 m below the current ground level. This was overlaid by the former medieval ploughsoil (503) of between 0.15 m and 0.25 m in depth. This was subsequently sealed by a 0.2 m deep layer of the former topsoil (502), the same as 302 and 402. At the western end of the trench this was overlaid by a 0.3 m deep by 2.4 m wide layer of building rubble (505), which was subsequently sealed below a 0.4 m thick layer of topsoil (501).

5.2 Finds***Small Finds***

5.2.1 A small crucible containing possible brass smelting residue was recovered from layer 303, a possible medieval ploughsoil. At this time it has not been possible to accurately date this find.

Bulk finds

5.2.2 Numerous fragments of peg tile were retrieved from the demolition layers within Trench 2 together with 2 fragments of medieval sandy grey ware from demolition layer 203 and a fragment of 18th/19th century earthenware flower pot from redeposited soil (211) within a possible former robber trench. The four trenches produced numerous remains of 19th century rubbish, including transfer printed, cream and stoneware pottery and bottle glass.

6 DISCUSSION AND INTERPRETATION**6.1 Reliability of field investigation**

6.1.1 The conditions during the evaluation were dry and clear with little intrusion by modern features such as services and land drains.

6.1.2 The location of the trenches and the percentage sample (10%) of the development area is believed to have given a good reflection of the overall archaeological potential of the site.

6.2 Overall interpretation***Summary of results***

6.2.1 The evaluation appears to have determined the limits of the medieval Manor House to the north-west of the existing building complex. This is suggested by the absence of building features such as robbed out walls, foundation trenches or demolition spreads within Trenches 1, 3, 4 and 5, suggesting that those features within Trench 2 represent the westernmost extent of the medieval Manor walls.

6.2.2 By combining the findings from this evaluation with those from the Archaeology South East report (ASE, 1996) on the excavations undertaken at the Manor during the last phase of building (Fig. 2), we can see that Wall 206 is a likely continuation of

Wall 154 and that Wall 208 is equally likely to be a continuation of Wall 179, with a possible corridor existing between the two. The chronology previously interpreted for this site identified these walls as forming part of a phase of extensions dating to the 15th century, composed of timber framed structures resting on sill walls. The width of 206 (0.3 m) and 208 (0.4 m) also confirms that they are sill walls for timber framing rather than foundations for stone constructed walls, which should normally be in excess of 0.6 m wide. Wall 215 from this evaluation is of identical construction, alignment and width to 206 and 208 suggesting that it was part of the same phase of construction.

- 6.2.3 Wall 214 is of more substantial construction, although its width still suggests a sill wall. The alignment of this wall differs considerably with those walls known to have been part of the Manor and may represent a later structure built following the demolition of walls 213 and 215, possibly in the 16th century. All the structures exposed during the evaluation had been subject to extensive robbing probably in the 17th and 18th centuries and possible truncation during 19th century landscaping for the current Manor, as witnessed by feature 105 within Trench 1.
- 6.2.4 The features exposed within the other evaluation trenches are in line with agricultural or horticultural use of the area. The presence of an earlier, possibly medieval ploughsoil (303, 403 and 503) within the westernmost trenches suggest that cultivation took place up to the limits of the manor. Both ditches 103 and 308 appears to have predated the early ploughsoil, however, as possible field boundaries they are still likely to be associated with agricultural/horticultural activity within the manorial complex.
- 6.2.5 Post-medieval cultivation and 19th century landscaping are represented by layers 202, 302, 402 and 502 with ditches 310 and 408 and pit 306 probably associated with 19th century occupation. The presence of deep layers of redeposited topsoil 301, 401 and 501 together with the buried rubble 505 probably occurred during the last phase of 20th century building construction.

Impact of the development

- 6.2.6 The focus of the former medieval structural remains as shown in Fig. 2 are limited to the south-east corner of the proposed development site in Trench 2. The remaining negative features from Trenches 1, 3 and 4 predominantly date to after the demolition of the Manor house. Therefore the only area of significant threat to the survival of the former medieval manorial complex will be the medieval walls (22.55 m AOD) revealed in Trench 2, which appear at 0.4 m below the present ground surface (23 m AOD). However, any impacts to this archaeologically sensitive area could be avoided through appropriate design of foundation depths and their locations.

APPENDICES

APPENDIX 1 ARCHAEOLOGICAL CONTEXT INVENTORY

<i>Trench</i>	<i>Ctxt No</i>	<i>Type</i>	<i>Width (m)</i>	<i>Depth (m)</i>	<i>Comment</i>	<i>Finds</i>	<i>Date</i>
1							
	100	Layer	-	0.3 m	Modern topsoil	-	C20th
	101	Layer	-	0.3 m	Modern made ground	Plastic	C20th
	102	Layer	-	>0.1 m	Alluvium	-	-
	103	Cut	0.8 m	0.3m	Boundary ditch	-	-
	104	Fill	0.8 m	0.3 m	Silt fill of ditch 103	-	-
	105	Cut	2.5 m	0.2 m	Garden feature/flower bed	-	C19th
	106	Fill	2.5 m	0.2 m	Redeposited/disturbed topsoil	Pottery	C19th
	107	Fill	2.5 m	0.1 m	Primary fill of 105	Tile	C19th
2							
	201	Layer	-	0.2 m	Modern topsoil/ landscaping layer	Brick, wood	C20th
	202	Layer	-	0.15 m	Original topsoil	Brick	C19th
	203	Layer	-	0.15 m	Demolition layer	Tile, mortar	C16th/C 19th
	204	Layer	-	0.14 m	Medieval ploughsoil	-	C12th/C 13th
	205	Layer	-	>0.1 m	Alluvium	-	-
	206	Wall	0.3 m	0.3 m	Robbed out foundations of wall	-	C15th ?
	207	Cut	0.7 m	0.3 m	Foundation trench for 206	-	C15th ?
	208	Wall	0.4 m	>0.1 m	Robbed out foundations of wall	-	C15th ?
	209	Cut	0.5 m	>0.1 m	Foundation trench for 208	-	C15th ?
	210	Layer	2.4 m	0.4 m	Demolition layer	Mortar	C16th/C 19th
	211	Layer	2.0 m	0.22 m	Backfilling of robber trench ?	Mortar, pottery	C18th/C 19th
	212	Layer	1.2 m	>0.2 m	Demolition layer	Mortar	C16th/C 19th
	213	Wall	0.3 m	0.2 m	Robbed out base of later wall	Tile	C16th ?

<i>Trench</i>	<i>Ctxt No</i>	<i>Type</i>	<i>Width (m)</i>	<i>Depth (m)</i>	<i>Comment</i>	<i>Finds</i>	<i>Date</i>
2							
	214	Wall	0.6 m	0.25 m	Robbed out base of an earlier wall	-	C14th/C 15th ?
	215	Wall	0.3 m	>0.1 m	Robbed out base of a later wall	-	C16th ?
3							
	301	Layer	-	0.3 m	Modern made ground	Brick, glass,	C20th
	302	Layer	-	0.2 m	Original topsoil	Brick, pottery	C19th/C 20th
	303	Layer	-	0.2 m	Earlier ploughsoil	Brick	C13th/C 15th ?
	304	Layer	-	>0.6 m	Alluvium	-	-
	305	Fill	1.1 m	0.65 m	Fill of Pit 306	Tile	C19th
	306	Cut	1.1 m	0.65 m	Rubbish pit	-	C19th
	307	Fill	0.7 m	0.15 m	Fill of Ditch 308	Pottery, bone	C12th/C 13th ?
	308	Cut	0.7 m	0.15 m	Boundary ditch	-	-
	309	Fill	0.8 m	0.2 m	Fill of Ditch 310	Pottery	C19th ?
	310	Cut	0.8 m	0.2 m	Boundary/drainage ditch	-	C19th ?
4							
	401	Layer	-	0.45 m	Modern made ground	Brick, glass,	C20th
	402	Layer	-	0.2 m	Original topsoil	Brick, pottery	C19th/C 20th
	403	Layer	-	0.2 m	Earlier ploughsoil	Brick	C13th/C 17th ?
	404	Layer	-	>0.3 m	Alluvium	-	-
	405	Fill	1.0 m	0.45 m	Fill of rubbish pit 406	Pottery, glass, cast iron	C19th
	406	Cut	1.0 m	0.45 m	Rubbish pit	-	C19th
	407	Fill	0.7 m	0.5 m	Silting fill of Ditch 408	Brick	C18th/C 19th ?
	408	Cut	0.7 m	0.5 m	Boundary ditch	-	C18th/C 19th ?
5							
	501	Layer	-	0.45 m	Modern made ground	Pottery, brick, glass	C20th

	502	Layer	-	0.2 m	Original topsoil	Brick, glass	C19th/C 20th
--	-----	-------	---	-------	------------------	-----------------	-----------------

<i>Trench</i>	<i>Ctxt No</i>	<i>Type</i>	<i>Width (m)</i>	<i>Depth (m)</i>	<i>Comment</i>	<i>Finds</i>	<i>Date</i>
5							
	503	Layer	-	0.2 m	Medieval/ post-medieval ploughsoil	Shell	C14th/C 17th ?
	504	Layer	-	>0.1 m	Alluvium	-	-
	505	Lens	2.4 m	0.3 m	Dump of modern building rubble	Brick, asbestos sheet	C20th

APPENDIX 2 BIBLIOGRAPHY AND REFERENCES

ASE, 1996 *Excavation at Grench Manor, Gillingham, Kent*

IFA, 1999 *Standard and Guidance for archaeological evaluations*

KARU, 1992 *Grench Manor, Gillingham, Kent*

KCC, 2004 *Specification for an Archaeological Evaluation in Advance of the Proposed Development of an Extension at Grace Manor Nursing Home, Grange Road, Gillingham, Kent*. Heritage Conservation Group

OA, 2004 *Grace Manor Nursing Home, Grange Road, Gillingham, Kent: Written Scheme of Investigation*

OAU, 1992 *Field Manual* (ed. D Wilkinson)

APPENDIX 3 SUMMARY OF SITE DETAILS

Site name: Grace Manor Nursing Home, Grange Road, Gillingham Kent

Site code: GIGM 04

Grid reference: TQ 7930 6847

Type of evaluation: 5 machine dug trenches, 50 m total length

Date and duration of project: 18th and 19th January 2005, 2 days

Area of site: 750 m²

Summary of results: Western extent of a 15th/16th century Manor, several medieval and post-medieval ditches and pits, and evidence of modern demolition deposits.

Location of archive: The archive is currently held at OA, Janus House, Osney Mead, Oxford, OX2 0ES, and will be deposited with the appropriate museum service in due course.

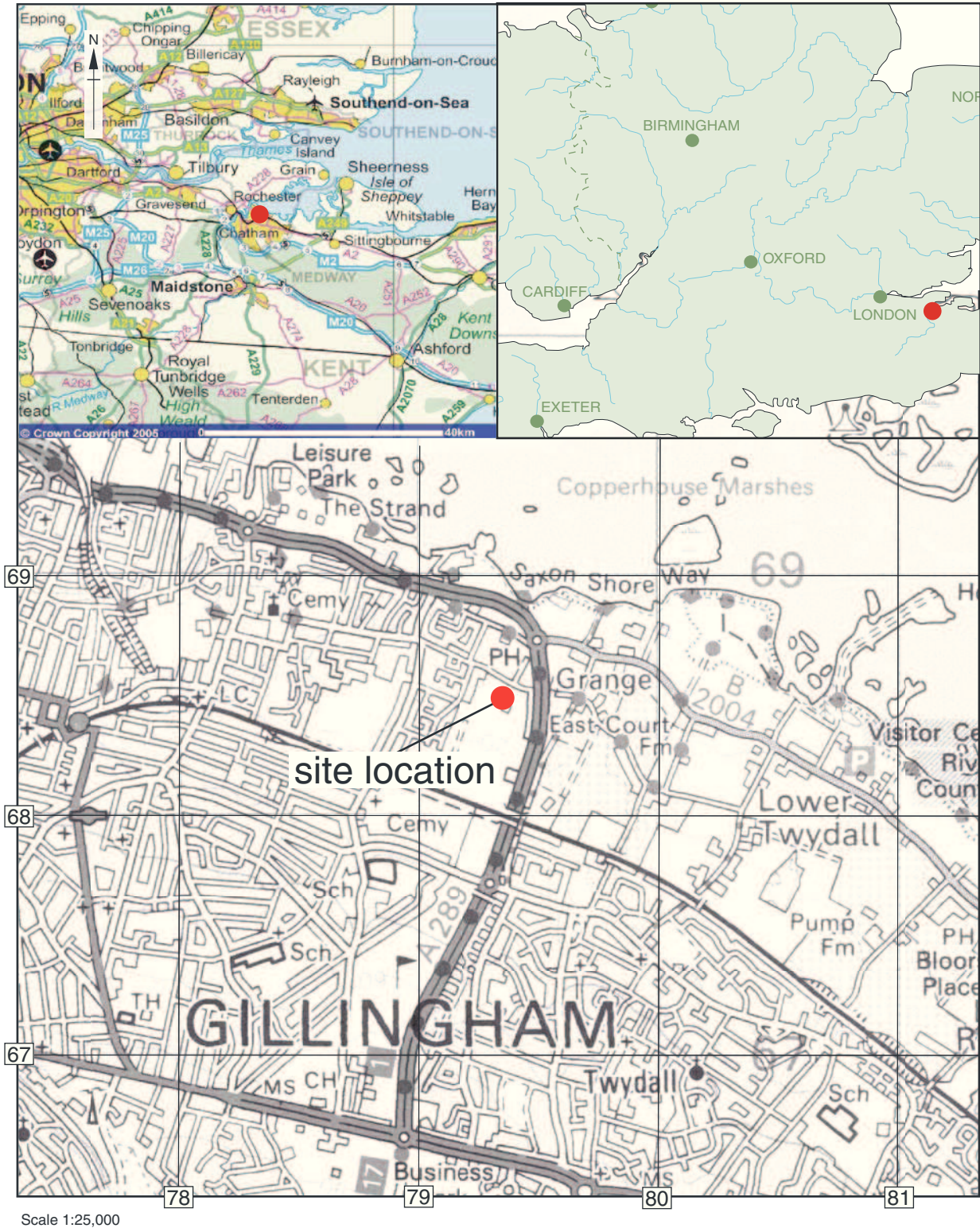

Scale 1:25,000

Reproduced from the Landranger 1:50,000 scale by permission of the Ordnance Survey on behalf of The Controller of Her Majesty's Stationery Office
© Crown Copyright 2001. All rights reserved. Licence No. AL 100005569

Figure 1: Site location

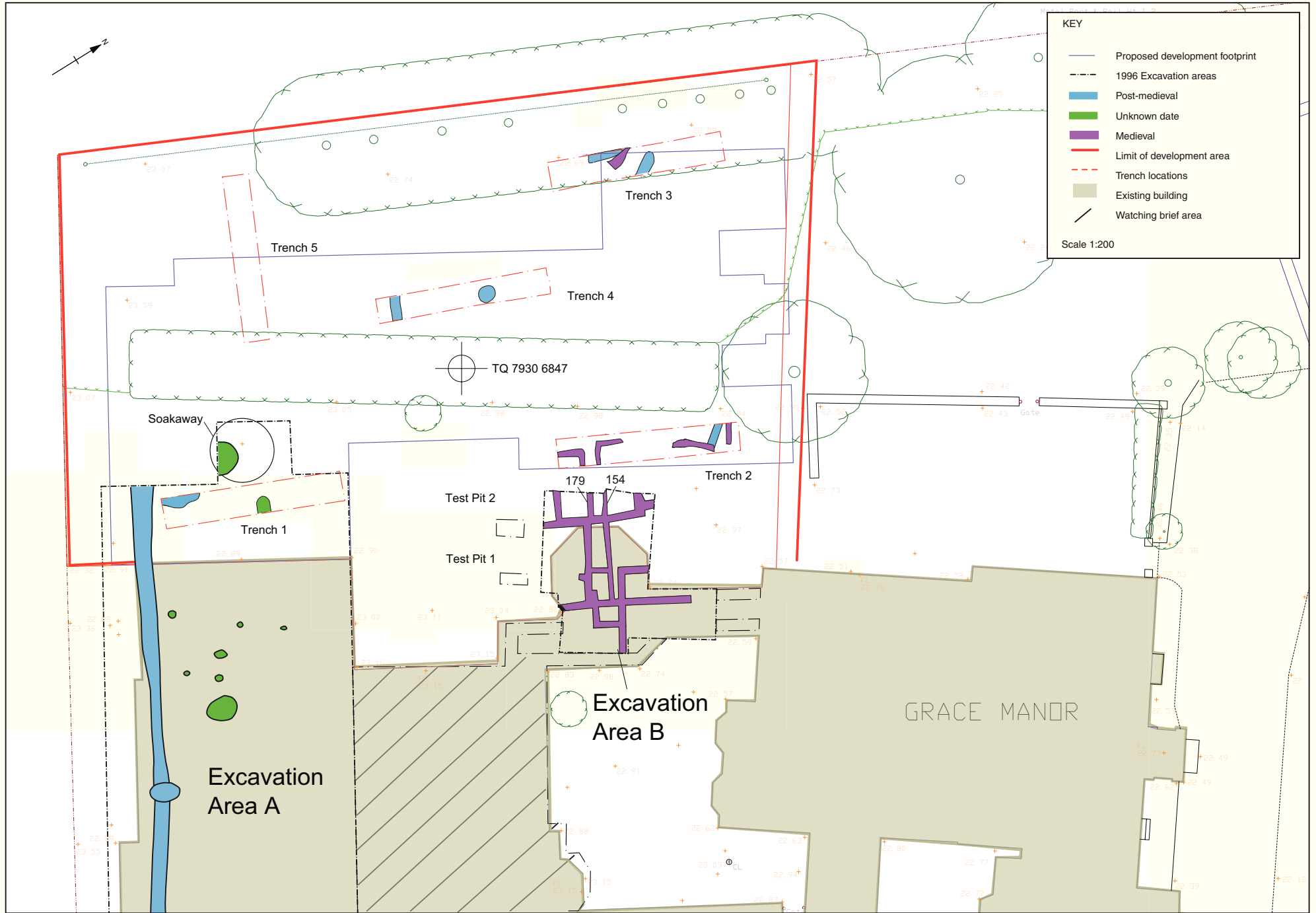

Figure 2: Trench location showing spatial relationships of archaeological features

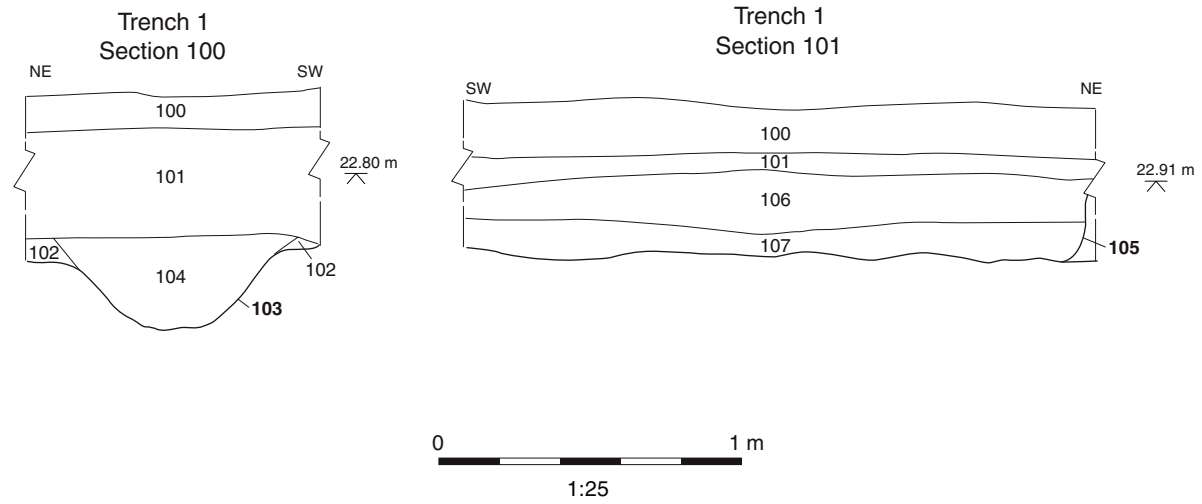
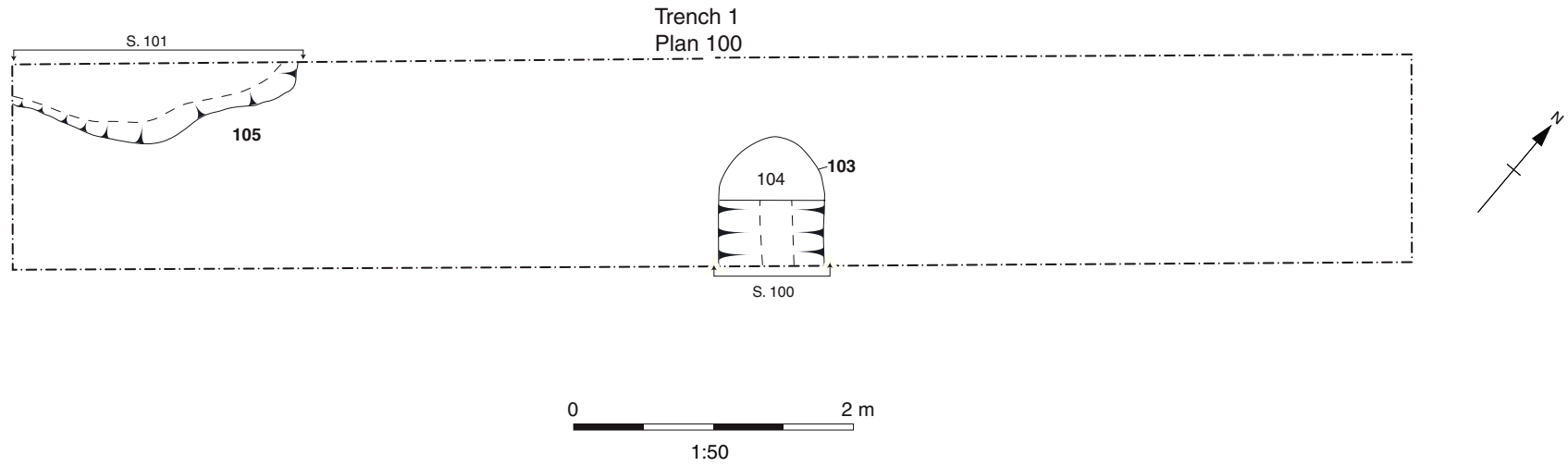

Figure 3: Trench 1, plan and sections 100-101

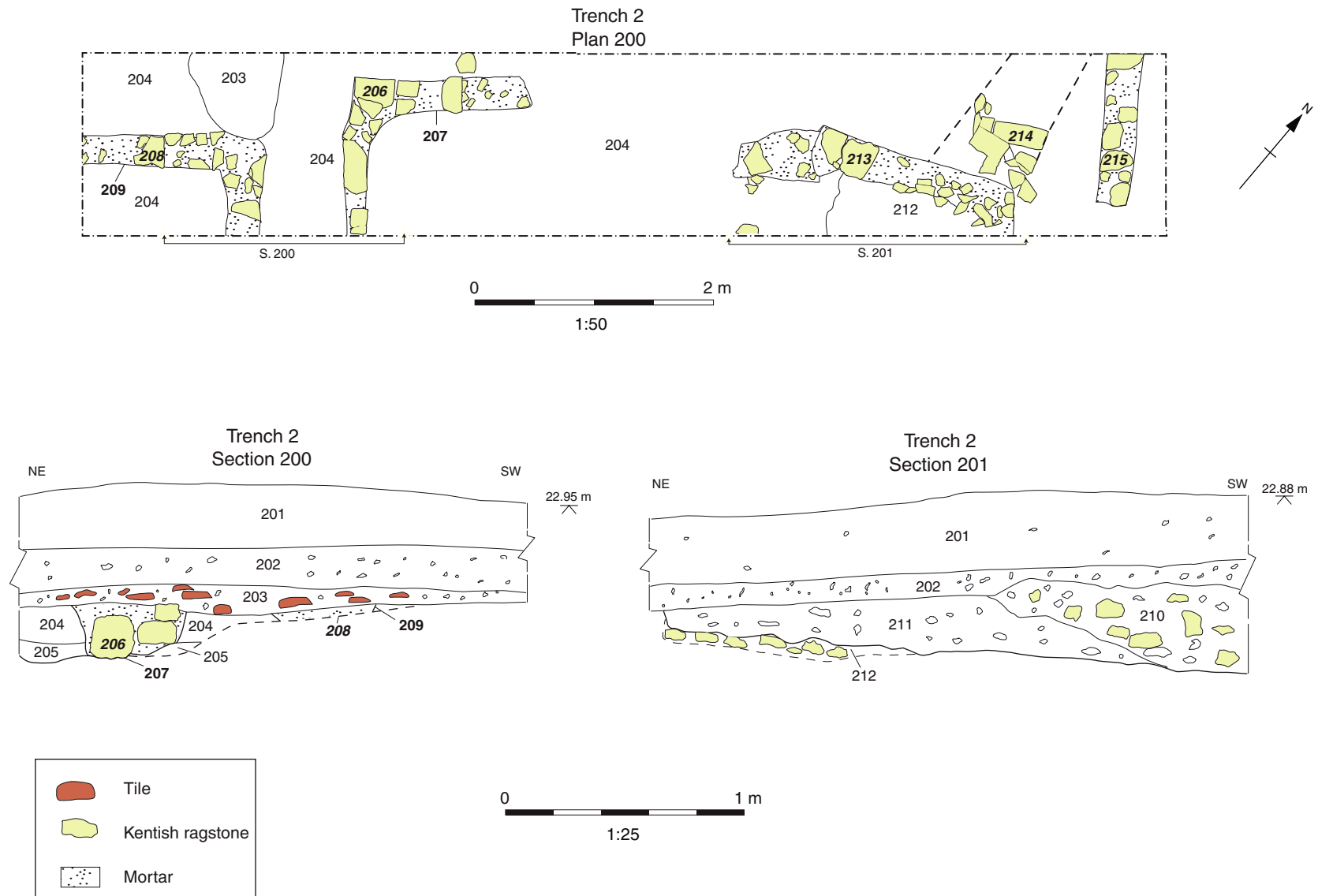

Figure 4: Trench 2, plan and sections 200-201

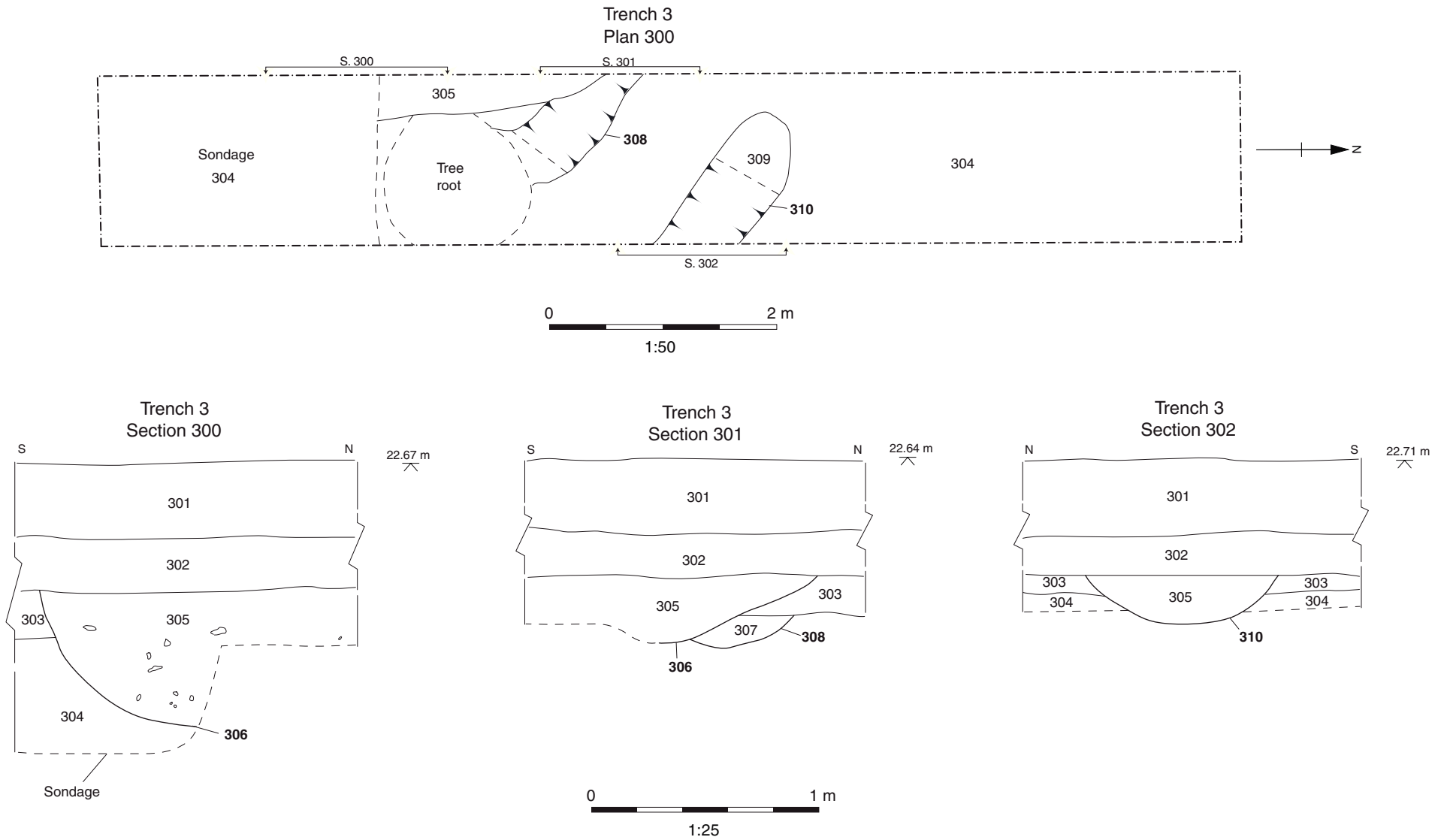
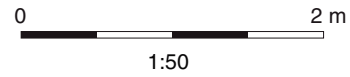
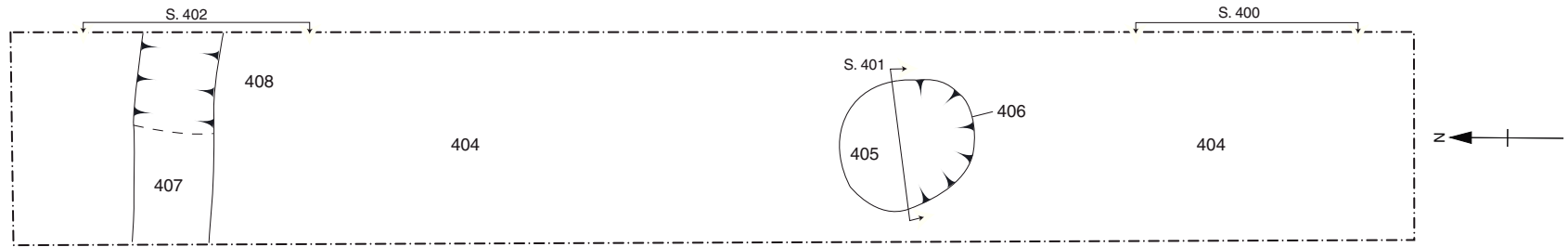
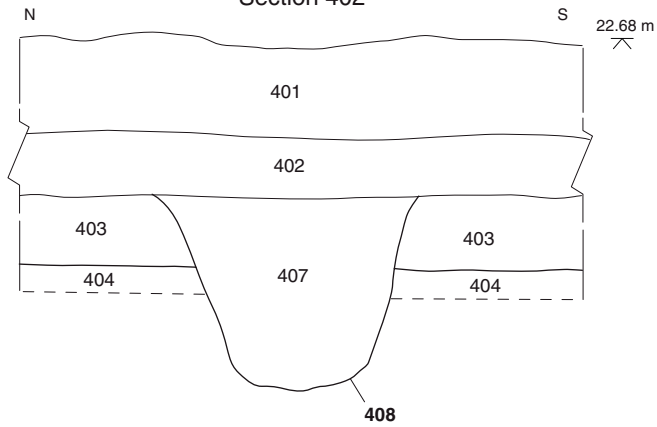

Figure 5: Trench 3, plan and sections 300-302

Trench 4 Plan 400



Trench 4 Section 402



Trench 4 Section 401

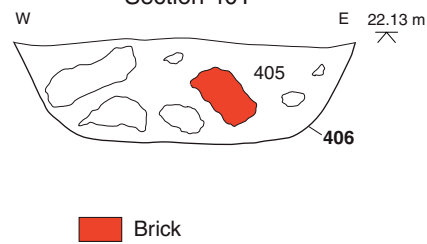

Trench 4 Section 400

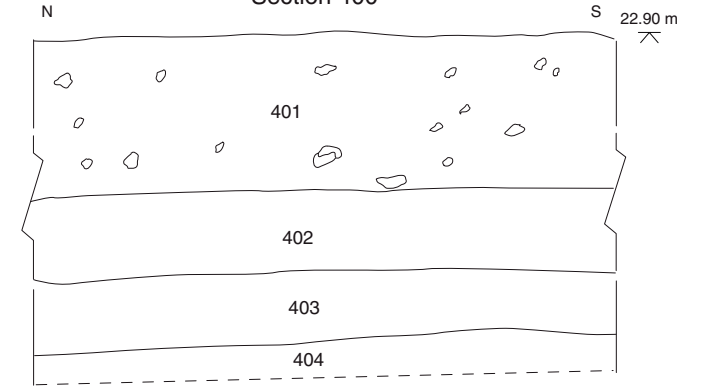

Figure 6: Trench 4, plan and sections 400-402

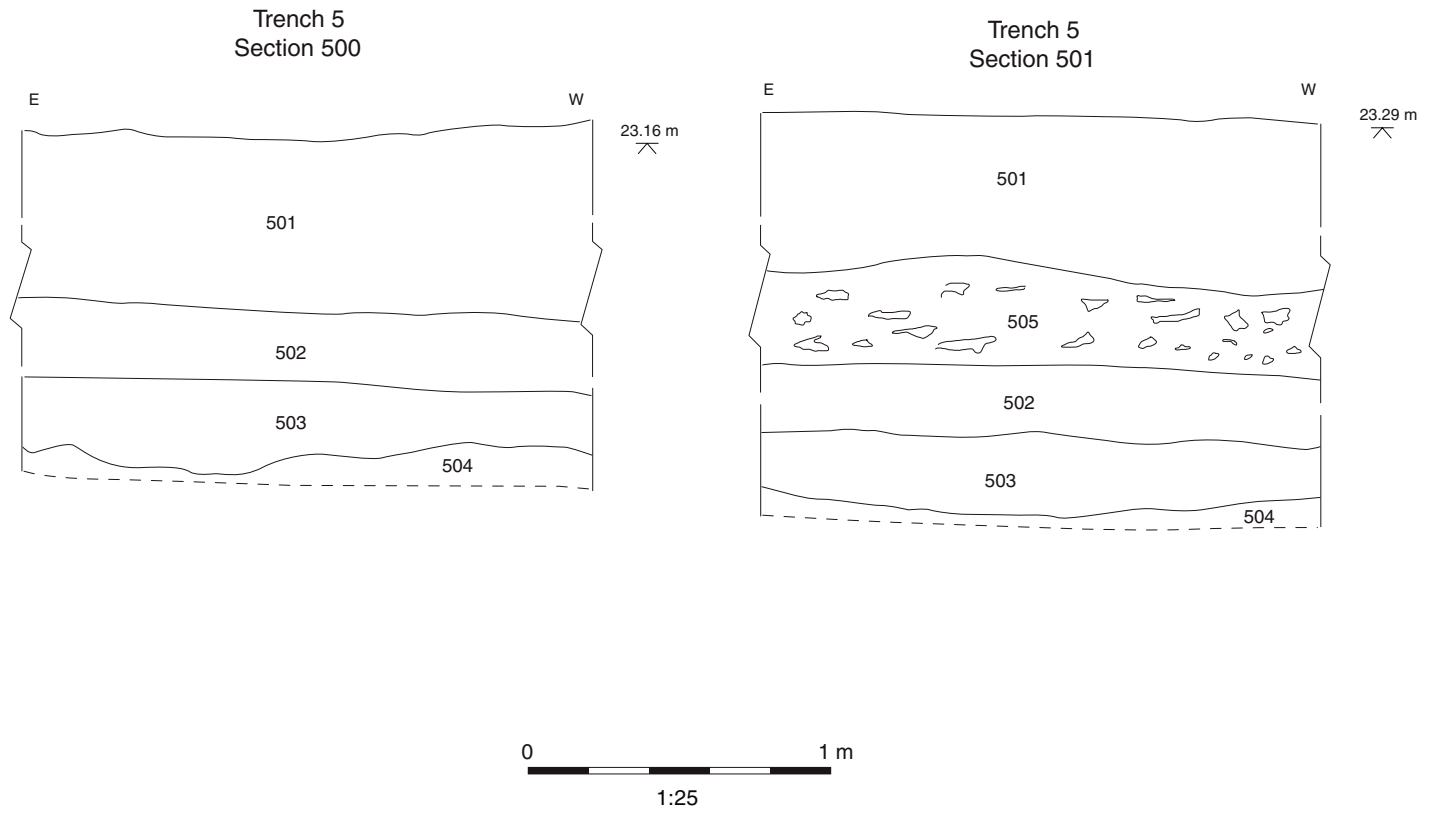

Figure 7: Trench 5, sections 500-501