

BUILD (OX)  
92105

CHAS  
522/93

The National Trust  
Thames and Chilterns Region

# CHASTLETON HOUSE STABLES

Archaeological Survey



Oxford Archaeological Unit  
June 1992

The National Trust  
Thames and Chilterns Region

# CHASTLETON HOUSE STABLES

Archaeological Survey



Oxford Archaeological Unit  
June 1992

# Chastleton House Stables: Archaeological Survey

**Summary:** *The stable block comprises a north wing with brewhouse and domestic offices, and a west wing with stables and hayloft. Although possibly built in two phases, the similarity of detailing in both parts suggests that they are nearly contemporary. The north elevation overlooking the garden and its gable end to the road were designed to have a domestic appearance, partly masking the internal dispositions. The cartshed may be the last remnant of the former barn.*

## 1. Introduction

This report has been compiled by OAU for the National Trust in advance of repairs to the Stable yard. It is the result of a non-intrusive visual inspection of the buildings, and seeks to determine the extent and details of the original building, and the sequence of alterations. Some parts of the building were obscured by ivy externally and modern decoration internally, and will require further investigation when cleared of these obstructions. Existing plans and drawings were used as the basis of the survey, though several details were recorded by measured drawings and record photographs, and the survey will include rectified photography as the next stage of work.

## 2. Documentary evidence

This study does not include any documentary research. The stables are likely to be contemporary with the main house, built for Walter Jones after 1605, for the building of which there is little direct evidence. The 1632 inventory refers to the *Wool howse, the Meale howse, the Brewhouse, the Milkhowse, the Stable and the Barne* (the latter containing beasts, hay and gear); the brewhouse was amongst buildings covered with Westmorland slate in 1803-4 (M. Dickens, *A History of Chastleton* (1938), 26 & 60).

## 3. Description

*[Stone is described as limestone if of cream colour and as ironstone if brown, though it is recognised that these are likely to represent more than two types of limestone. Numbers refer to openings shown on the plans (Figs. 1 & 2). Standard details are described separately at the end]*

### 3.1 EXTERNAL ELEVATIONS

The buildings are all of coursed squared rubble, with ashlar detailing to doors and windows; the roofs are of cotswold slate.

### 3.1.1 *South elevation of brewhouse range*

The north side of the stable yard is of irregular appearance, though this has largely been brought about through secondary alterations. The *north-west corner* is marked by both walls curving in towards the corner, to allow maximum space for the two openings in the wall of the brewhouse range [1, 2]. Neither of these need be original features. The upper window [1] has a four-centered head with hollow-chamfered jambs, like no other window in the building, and may be an import (see below). At ground floor the window [2] has a masonry break below suggesting that it was originally a door.

East of the drainpipe consistent masonry coursing appears to run continuously between the ground and first floor as far as the east end of the range. In the *first floor* were three openings [3, 5, 7] of which the last is a standard two-light window (Fig. 4a), and the other two were perhaps once similar judging from the blocked splayed reveals visible internally. On the outside the first of these [3] has a marked break where there was a dormer window occupying the top few courses in the wall. Below this is the possible outline of the eastern side of the former window, but the coursing runs westwards uninterruptedly as far as window [1], so blocking may have occurred when the latter was inserted. The second window [5] currently has a dormer at the top of the wall, while the outline of the blocked window may be faintly apparent below though it is well concealed.

On the *ground floor* there were three openings matching those above [4, 6, 8]. The first is a standard two-light window [4], though possibly secondary as below it there are breaks indicating a former door opening here. Next is a blocked window [6], whose jambs are clear externally. Then there is a door [8] of standard form (Fig. 3), with a re-used timber lintel inside and straight jambs. East of this is a small low opening [9] with a wooden frame, perhaps a hatch or an added light to the space under the stair; beyond this is a door [10] with straight jambs and a wooden doorframe, and an external wooden lintel. A masonry patch over the door suggests that the timber lintel may be a replacement for a stone one.

### 3.1.2 *East elevation of brewhouse range*

Currently much obscured by plants, this elevation has a blank ground floor, a four-light window on the first and a three-light window on the second floor. The masonry was treated with some regard to its appearance, having irregular courses of wider and narrow stones.

### 3.1.3 *North elevation of brewhouse range*

The north side overlooks the small garden between the 'service' side of the house and the road. The first floor has three standard three-light windows, roughly evenly spaced [16, 19, 21]. Consistent masonry coursing appears to

run continuously from end to end below the windows, and between openings on the ground floor, with one exception. The ground floor has two large and one small doorways of standard form [15, 18, 22] (except door 15 lacks chamfer stops). The opening at the east end has with a ?modern chamfered timber lintel [14], the masonry over it suggesting secondary insertion; the door has plain ashlar jambs and internal soffit beams, partially blocked with masonry and a window in recent times for the lavatories. The two ground floor windows [17, 20] are of irregular form, distinct in both having hollow-chamfered mullions, and one [20] being of four lights with a central king-mullion. Below this window is a hiatus in the masonry coursing, perhaps representing no more than a break in construction. The door at the west end [22] is smaller than the other two, and placed somewhat lower due to the falling ground level. There are fragmentary traces of whitewash on this wall, coincident with patches of lichen.

#### 3.1.4 *West elevation of brewhouse and stable*

The western end of the brewhouse wing makes some concessions to its being a prominent gabled end to the road, seen together with the western side of the main house. The masonry consists of alternate thick and thin courses of limestone and ironstone, though this feature is only present for the width of the gable, and is not continued into the wall of the stable. There are three standard windows of three lights in the gable wall [23, 24, 25], the lower one of slightly wider dimensions. As was not uncommon at the time, the upper window only lights the attic space, and was only included to make the elevation more imposing.

The junction with the stable range is partly covered with ivy, but is clear enough from the change in masonry type; it may not represent any long temporal break between the different parts of the building, but just a return to less distinctive masonry. The lower part of the stable wall contains more ironstone, but not in separate courses (this is more obvious since the lower part of the wall is cleaner, presumably washed by rainwater); the whole wall appears to be built as one up to the level of the window sills. There is one low opening [27], possibly a drain exit, and an inserted stable window [30] on the ground floor. Above, two windows [28, 31] are visible externally, of two and three lights respectively; there was certainly one more [26] at the north end, and possibly another [29] between the existing ones, but these have been blocked and are scarcely visible on the outside.

#### 3.1.6 *South elevation of stable*

This wall has no openings, but built against it is a small lean-to privy, with an adjacent area that may have been an ash-pit (there are traces of burning on the gable wall). The privy is not bonded into the stable wall, but is of built of similar stone; an area of disturbed stonework next it at the southeast corner is probably no more than a patched repair, perhaps



connected with the cracks visible in the east wall.

### 3.1.7 *East elevation of stable*

The ground floor has three four-light windows [33, 36, 38] of standard form, with two standard doors [34, 37] between them. The first floor has a small central door [35] to the hayloft, with a standard type of surround. On either side of the door there is consistent masonry coursing running the full length of the range, except at the south end where there is a blocked window [32] above the window below. There was no corresponding first-floor window at the north end.

## 3.2 INTERNAL FEATURES

### 3.2.1 *East end of brewhouse range*

At the *east end* there was a through passage against the stone wall of the present kitchen, with a plain door opening [10] at the south end and a rebated door [15] at the north end, each with double timber lintels internally (this is a standard feature). The original arrangements here are obscured by the modern insertion of lavatories, but it is likely that there was a partition here below the principal ceiling joist since there is another door [14] in the north-east corner, now opening into a store. There are three ceiling bays here, with fourteen common joists running between the principal joists and the stone partition wall. As with all original floors, the joists are chamfered, and have soffit tenons with diminished haunches (sloping back), or 'spurred tenons' (sloping forward) where the principal has a waney edge (Fig. 5). This unlit room at the end of the range may have been the 'meal house' of the 1632 inventory.

At the south end of the stone wall is a timber door frame supporting the string for the framing of the *stair*, now mostly removed, giving access to the first floor. This has a turned wooden post at the top (Fig. 8), evidently re-used, since it has a large chase mortice for a downward rail that is not used in its present position. It is framed to a handrail and sillbeam over the stairwell, resting on the floor joists and connected to the other corner post which is octagonal with a roughly turned head. The stairwell has caused the floor in the adjacent two bays to be framed differently, with common joists running north-south over the present kitchen.

The *first floor* at the east end was a large room, once plastered and lit with windows on the north and east, and with chamfered ceiling joists. There are candle burns on the corner post of the stairwell, and despite the lack of heating this may have been a servant's room, but it is not impossible that it was the 'wool house' of the 1632 inventory.

A door at the head of the stair leads up two steps to the room over the brewhouse, and it was probably from here that there was a stair to the *second floor*, since the tie beam above the partition wall has a central door sill and posts that may have been a door frame. There is no other evidence of any direct access from the eastern room below, already described. This upper floor was lit from the east end only, and had a boarded floor and plastered walls. Although unheated, it is more likely to have been servants' accommodation, being less easy of access for woolsacks.

The *roof* has trusses with similar spacing to the floor joists below, and has principal trusses with a tie beam and single collar, and two butt-purlins. The purlins are slotted onto free tenons that pass through a mortice in the principal rafter (Fig. 7), and have a tapered inner face allowing them to be closely fitted into the housing on the rafter. This is a not uncommon local post-medieval roof type, and is found elsewhere at Chastleton. The common rafters (many of which have been replaced) then rest on the outside of the purlins and the wall head.

### 3.2.2 *Brewhouse*

The brewhouse was reached from a door to the stable yard [8], opposite which was another door [18] leading towards the main house (and the door to the beer cellar). On account of the stair, it cannot have been reached from the east end of the range as it is now. At the *east end* is a stone wall reaching up to tie-beam level: part of the original build since it is bonded in to the side walls and is continuous with the door jambs at each side. At the south end is a door with a timber lintel and a chamfered door lintel with mortices for the door frame. This led to a passage under the stairs (lit by the small window [9]) and the present kitchen. This has one window, but modern fittings have obscured any original features. It is another candidate for the 'meal house' of the 1632 inventory.

The *ground floor* may have had partition by the cross passage, judging from the area of brick paving, but there is no evidence for this in the side walls. The room was lit by two windows [4, 6] to the stable yard (one of which has been blocked); these have stone segmental arches over them. The one large window [20] on the north side has a timber lintel (with mortices from a previous use), and is a non-standard window with hollow chamfers, and some possibly original iron fittings (Fig. 4b). The *west wall* is not bonded in to the side walls, and seems to be a later addition or replacement, being of consistent limestone build with marked putlog holes, of slightly different character from the side walls. There is a central fireplace, giving access to an internal oven on the north side, while on the flanking wall on the north there is some indication of a door to a second oven. The ?modern steps up on the south side of the fireplace lead to a recess with an arched stone head, probably for the brewing vat, which may have had a separate stoke hole. So it would appear that this was a bakery and brewery, as was not unusual.

The *first floor*, as already mentioned, was reached from the stair and door at the east end. Its floor has been removed, but there are two principal joists (resting on timber pads in the side walls), with mortices for fourteen joists (with diminished haunches). Internally it is clear that there were three standard windows on the south wall, though one [5] was partially blocked and turned into a dormer, and the other [3] similarly so but then completely blocked at a later stage; there is no evidence for the date of these alterations, but the dormer appears to be of no great age. There was one window [19] in the north wall. Although there must have been a stair leading up to the attic at the east end, there does not seem to have been a floored attic over the brewhouse, and it must have been open to the roof. As a well-lit room over a heated room, it is likely to have been used for servants' accommodation (if not a wool store). In the west wall above the 'brewing vat' is a blocked door (a timber lintel over an offset in the wall), and above it is a small window opening to the west end attic, with no obvious function except as access to the attic level there. The *roof* is of three bays, similar to that described above.

### 3.2.3 *West end of brewhouse range*

As described above, there may originally have been a direct access from the yard to the rooms at the west end of the range, though they are now reached from the stable. Similarly there was a door [22] on the north side, though this cannot now be seen from the inside. On the *ground floor* there are two rooms, separated by a thick partition wall (partly of brick), with two large principal ceiling joists running east-west (unlike those in the rest of the range); they are chamfered and probably original, though the common joists in the *west room* are of 19th-century date, like the tongue-and-groove panelling which covers the walls of what was presumably the tack room. The *eastern room* is mostly plastered, but the rubble east wall is partially visible (papered over whitewash) with a brick patch where there was a fireplace, replaced by a small modern enamelled range (Ideal Cookanheat No. 35). The door from the stable has an arched head, and the window reveals are skewed to fit round the door and the partition wall to the brewhouse. Investigation after fittings have been removed may reveal whether the former door was similarly constructed. There may also be some evidence to indicate whether this was the 'milk house' of the 1632 inventory, as would seem likely.

A modern stair in the north-west corner of the room lead up to the *first floor*, which is divided by a modern brick partition. In the east wall is a central arch of ashlar with a brick blocking, probably for a fireplace, and beside it to the south are ashlar quoins for the door into the first floor of the brewhouse, mentioned above. This may have been the only original access to the first floor, and the door through to the stable loft has brick jambs and is probably modern. There is a standard three-light window [21] in the north wall, but the window [1] in the south wall is of non-standard



form, hollow-chamfered and having a round head externally and blank spandrels internally; it appears to have been made for a normal window opening and has been inserted into the wall with its eastern jamb adjusted for the partition wall, which has been cut back to make space for it (though this may only have occurred when the partition was added or rebuilt).

The ceiling is all of light modern softwood, and there is no trace of an attic room here (it was not plastered), though there is a window [23] in the west gable which, as described above, was probably only built for appearances sake. The *roof* is the same as described before, with small common rafters (many of softwood), probably belonging to a 19th-century reslating with torching. The stable range ends with a stone gable, but purlins from its former roof come through to meet a valley rafter in the brewhouse range.

### 3.2.4 *Stable range*

The stable is unevenly divided into two parts, with a stair between them. At the *north end* are two stalls, of no great antiquity. The ceiling is original, with fourteen common joists on a large chamfered principal (Fig. 6a). As shown on the figure, the chamfer stop at the east end is nearer the wall than the one at the other end; this does not imply re-use, but was probably intentional to allow for a hay manger at the west side, so that hay could be let down directly from the hayloft into the stalls. Although the flooring of the attic has been renewed, there are some indications on the principal floor joists of former attachments for this.

The *stair* is built on a substantial stone ramp and is wooden, with stud partitions on each side, having lath and plaster faces towards the stables, and with rough plank rails internally, but no plastering. This is probably all of 18th or 19th-century date, and may be covering a plain stone stair. The door to the stair is a simple planked affair, but there is some re-used 18th-century panelling beside it. There is a door through to the next stable, but this now leads into a stall, and may be no older than the stair.

The *south stable* has five stalls, two windows to the yard and a small window to the road. The stalls, perhaps 19th century, have planked partitions and iron grills at the top; they were made all together and have paired doors that allow the stalls to be joined or separated. The paving of blue engineering brick is probably contemporary. The ceiling has been renewed (Fig. 6b) with a higher series of softwood joists and a plaster ceiling, but the principal joists are as described in the other stable. The window mullions have at one time been cut for horizontal bars, but now have vertical iron bars to which the glass is attached.

The *hayloft* must always have been just that, despite the windows on the road side, since there is no sign of domestic use, though the walls were plastered and whitewashed. The door to the yard was for lifting up the hay

(there is an iron wheel and chain for lifting the bales), and as suggested above, there may have been traps to let the hay down into the mangers in the stalls. The door to the north range is probably 19th century. The west wall windows were necessary to light the interior, but were also designed to present a symmetrical front to the road, though this has changed with numerous alterations. The northern one [26] has been partly and then entirely blocked, the southern one [31] has two of its three lights blocked. The central two-light window [28] is entire, but may have had a precursor [29] to its south, since there is a timber lintel and single jamb (about opposite the door), but this is most likely just a change of plan during building, and the lintel may have been a pad for a tie beam. As mentioned above, there is one blocked window at the south end of the east wall, but no evidence of a matching one at the north end. At the south end are timber binding beams across the corners, which are probably original. The north wall has a gable, as described above, but there are no obvious breaks in the masonry to suggest that this was added to an earlier wall; the north-west corner seems to be bonded in, and all the indications are that the two wings were contemporary.

The *roof* has mostly been replaced with four 18th/19th-century king-post trusses carrying two purlins, but towards the south end is a single ancient truss with a collar and two raking queen struts.

### 3.2.5 *East range of courtyard*

The cartshed/garage at the north end is of various periods. The south wall is of fine coursed limestone rubble with ashlar quoins and extending up the gable. The north wall is entirely of ironstone, with no quoins on its west corner, and only a single knee at the foot of the gable; the east wall is a mix of even courses of ironstone and limestone, and limestone quoins. Inside is a single truss similar to those in the other ranges, supported on an ashlar pier at the front. This was probably fitted out in the 19th century as a coachhouse, and later became a garage and still later a stable. It is likely that the unroofed walls continuing south of the building were once part of it, and that the present building is the converted end of a longer range. Since the 1632 inventory mentions a barn, that may have been here, if not in a separate farmyard. The garden wall is high and substantial enough to be the side of a barn, and there is an otherwise unexplained straight joint some five metres south of the cartshed, which may have been an entrance. The stone walled pens further south as far as the wall of the yard may also have been part of this building, but its existence could only be confirmed by excavation.

### 3.3 DESCRIPTION OF STANDARD DETAILS

*Doors:* (Fig. 3) Four-centered arch consisting of two or three large pieces of ashlar of irregular outline; jambs with plain chamfer, stopped at join with lowest stone, which has a plain triangular (?curved) stop; Internally, most have a rebate for the door, and two beams supporting the soffit of the opening (the door lintels are flat slabs on the face of the wall, and only the jambs below have a return into the reveal).

*Windows:* (Fig. 4a) Hood moulds over a separate lintel, with plain-chamfered mullions and a sloping sill. Between two and four lights (mostly three), with a variety of heights and widths; this, together with the poor fit of many mullions to the sills and lintels, may suggest that sills and lintels were made in pairs, and the other stones produced in non-standard lengths that were then cut to size. A few windows have hollow chamfers (Fig. 4b)

*Window fittings:* (Fig. 4b) Many window jambs and mullions are externally drilled as if for fitting bars or shutters. The variety of window leading suggests replacement at different times. Older windows are perhaps those with external iron bars to which the leaded lights are fitted with wire twists; the opening casements have iron frames and some of these have single or double catches to close the windows, and an attached handle at the bottom of the frame to open or shut the window; externally some of these have curved runners with sprung bands to support the open windows.

*Floor joists:* (Fig. 5) Most original floor joists are square or upright rectangular, and have soffit tenons with diminished haunches. These only operate when meeting a square arris on the principal joist (Fig. 5a), and where this is waney the shoulder may slope forward rather than back, forming a 'spurred' tenon (Fig. 5b).

*Purlin scarfs:* (Fig. 7) The principal rafter has a mortice containing a free tenon that protrudes on each side of the rafter. The purlins have tapered ends (only on the inner face) and a mortice on their soffits; they are slotted over the free tenons, introduced a short way into the mortice in the rafter, and double-pegged to the tenon. This is a not uncommon regional type of scarf.

*Rendering:* Traces of whitewash or thin render on the north elevation are marked by presence of grey lichen. Petrification of lichen with run-off from downwater was suspected, but rather the lichen may have helped the continuing adhesion of the coating, or been attracted by its chemical content. The western elevation has traces of render/whitewash at higher levels, but has been cleaned to the natural stone colour below; this is probably a result of water running off the roof.



#### 4. Summary

##### *North range*

Probably a three-part plan, with show front to north and west. East end with through passage, one room below and stairs leading to two large rooms above on first floor and attic, with plastered walls but no heating (also access to room over brewhouse). Possibly servants' accommodation, and woolstore. Altered by modern construction of lavatories on ground floor, creating small store space at east end.

Central part with through passage, two rooms at ground floor and large well-lit room over open to the roof. A brewhouse and bakery, possibly by conversion, since the dividing wall and chimney appear to be inserted. The stack comprises brewing copper, fireplace and oven. Altered by blocking of ground-floor window and conversion of two top windows to dormers in C18 or C19, and removal of first-floor common joists. The room above was probably servants' accommodation.

Western part with former access from yard and to the garden, was two rooms, possibly the 'milkhouse'. The first floor was reached from the brewhouse, until it was converted into self-contained accommodation.

##### *West range*

Perhaps slightly later than North Range, but of similar construction. Stable in two parts with central stair, hayloft over with door to yard and three windows to west, probably with traps on west side to let down hay into stalls. Altered by partial and complete blocking of windows in west wall, creation of new small window at ground floor, and C19 stable furnishings, including trap and hoisting wheel to move hay, and reflooring of southern stable.

##### *Other buildings*

The cartshed/garage is a complex building, probably made up from the remains of the barn which is mentioned in the 1632 inventory; the same may be true of the shed to its south.

#### 5. Further work

Re-examination of external walls after removal of ivy; investigation of interior of stable flat after removal of C20 fittings and wall coverings; possible excavatiuon for foundations of barn to find its extent.

Oxford Archaeological Unit  
June 1992



## List of figures

- 1 Ground plan showing location of features.
- 2 First-floor plan showing location of features.
- 3 Details of standard door.
- 4a Details of standard window (external).
- 4b Details of non-standard window 20 (internal, with fittings).
- 5a Floor joists, with diminished haunch joints.
- 5b Floor joists, with spurred tenons on waney edges.
- 6a Stable ceiling, north end, with long and short chamfer stops.
- 6b Stable ceiling, south end, with replaced joists.
- 7 Roof detail: purlin joints to principal rafter.
- 8 Brewhouse: detail of turned stair newel.

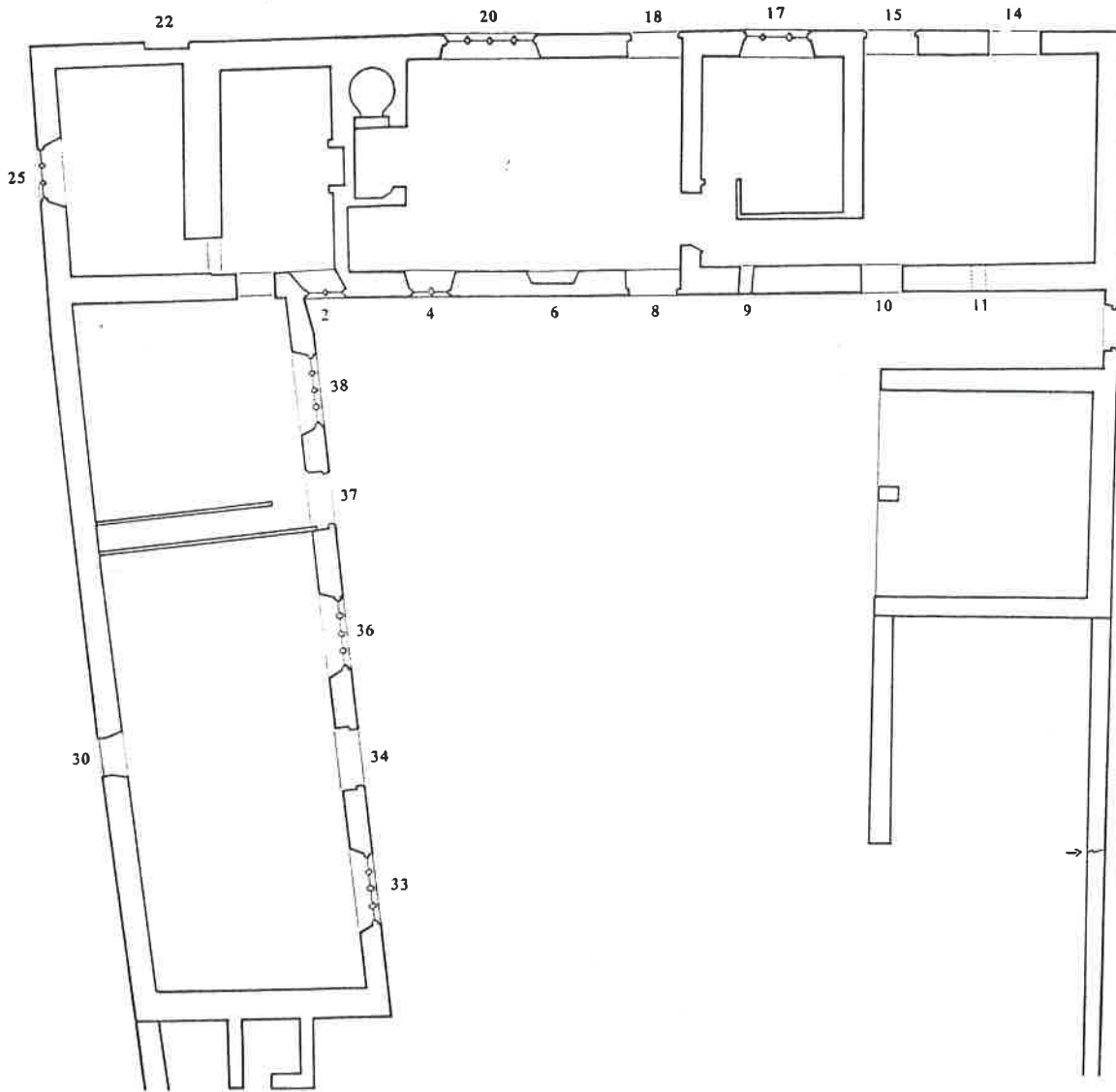

Fig. 1 Ground plan showing location of features.

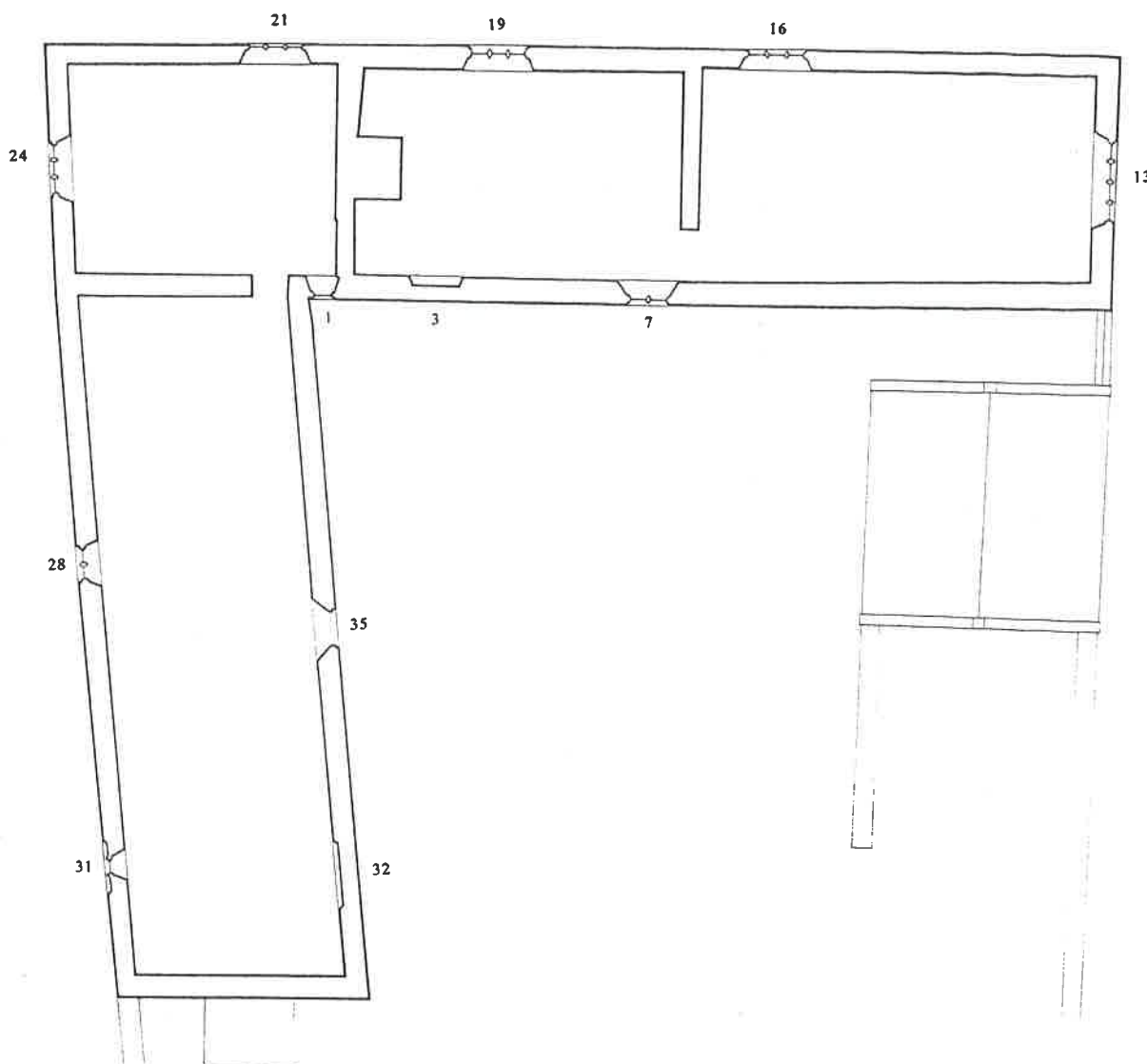
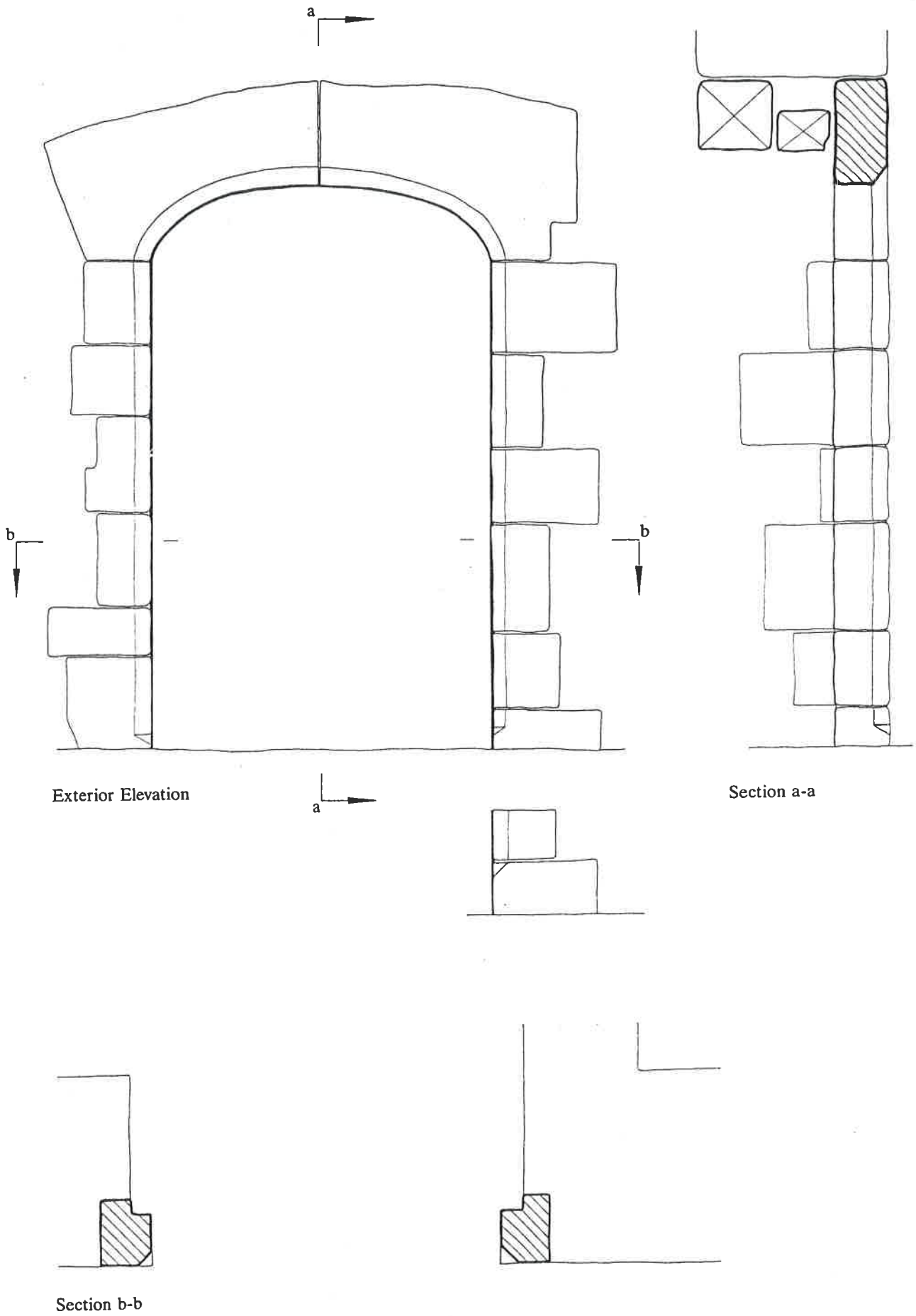

Fig. 2 First-floor plan showing location of features.



Exterior Elevation

Section a-a

Section b-b

Fig. 3 Details of standard door.



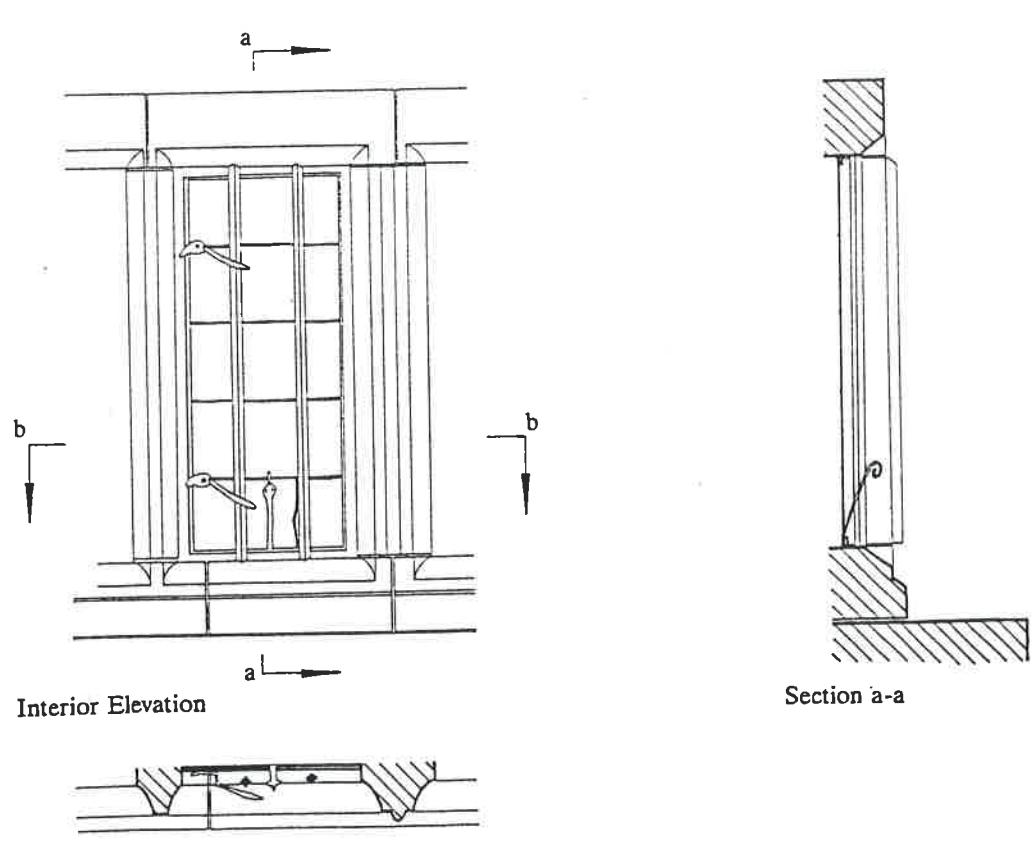
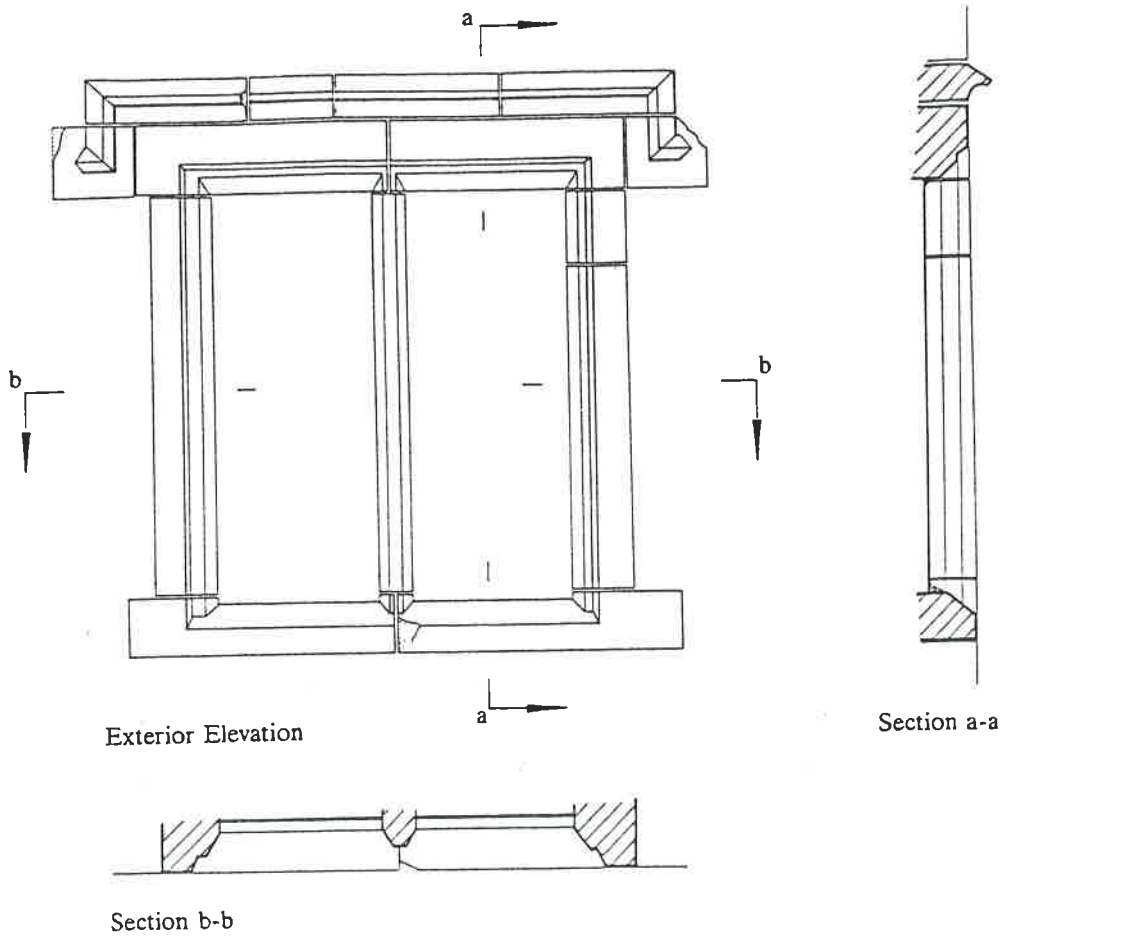

Fig. 4a  
Fig. 4b  
Section b-b

Details of standard window (external).  
Details of non-standard window 20 and fittings.

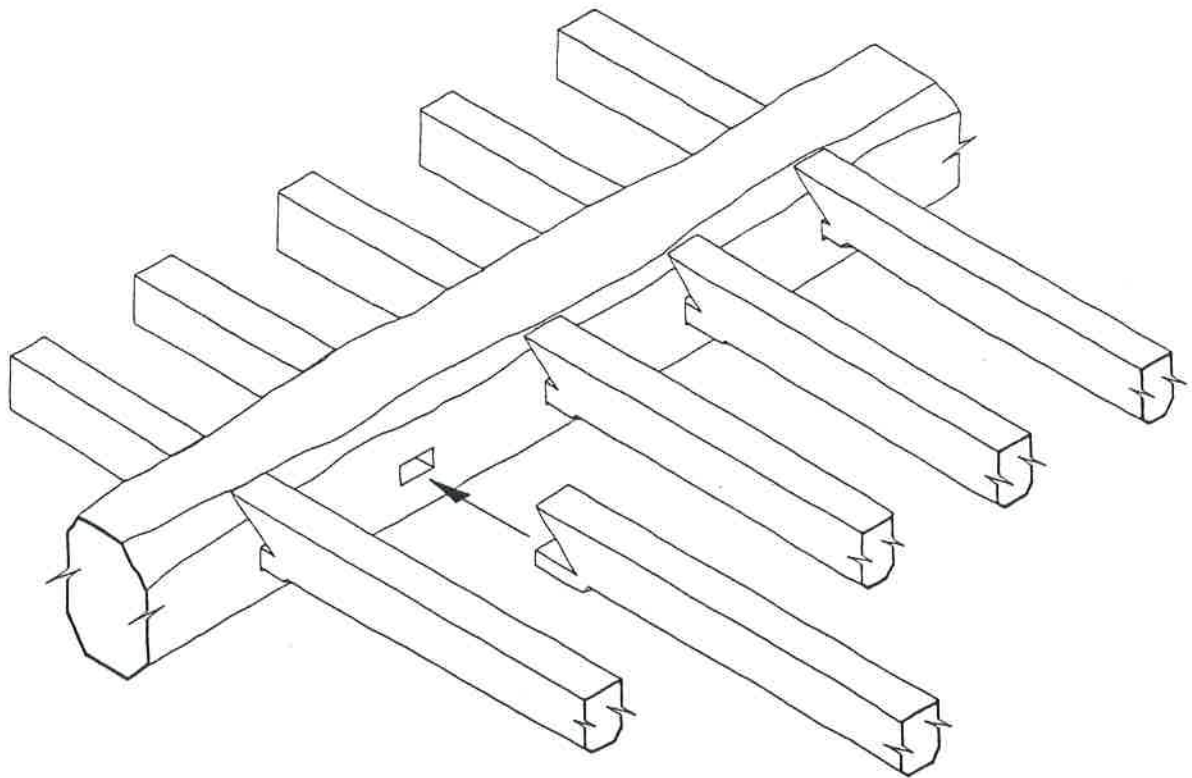
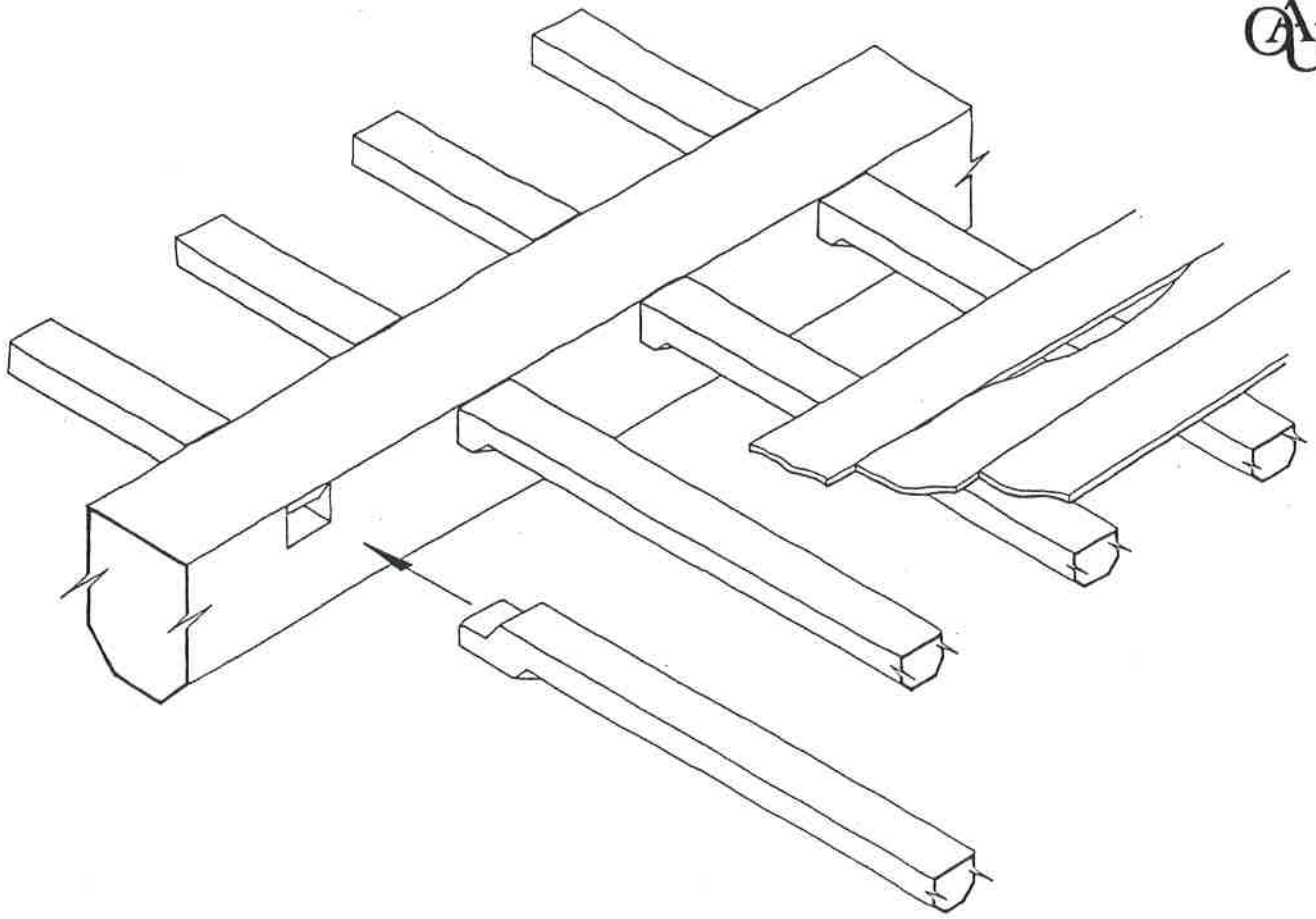

Fig.5a  
Fig.5b

Floor joists, with diminished haunch joints.  
Floor joists, with spurred tenons on waney edges.

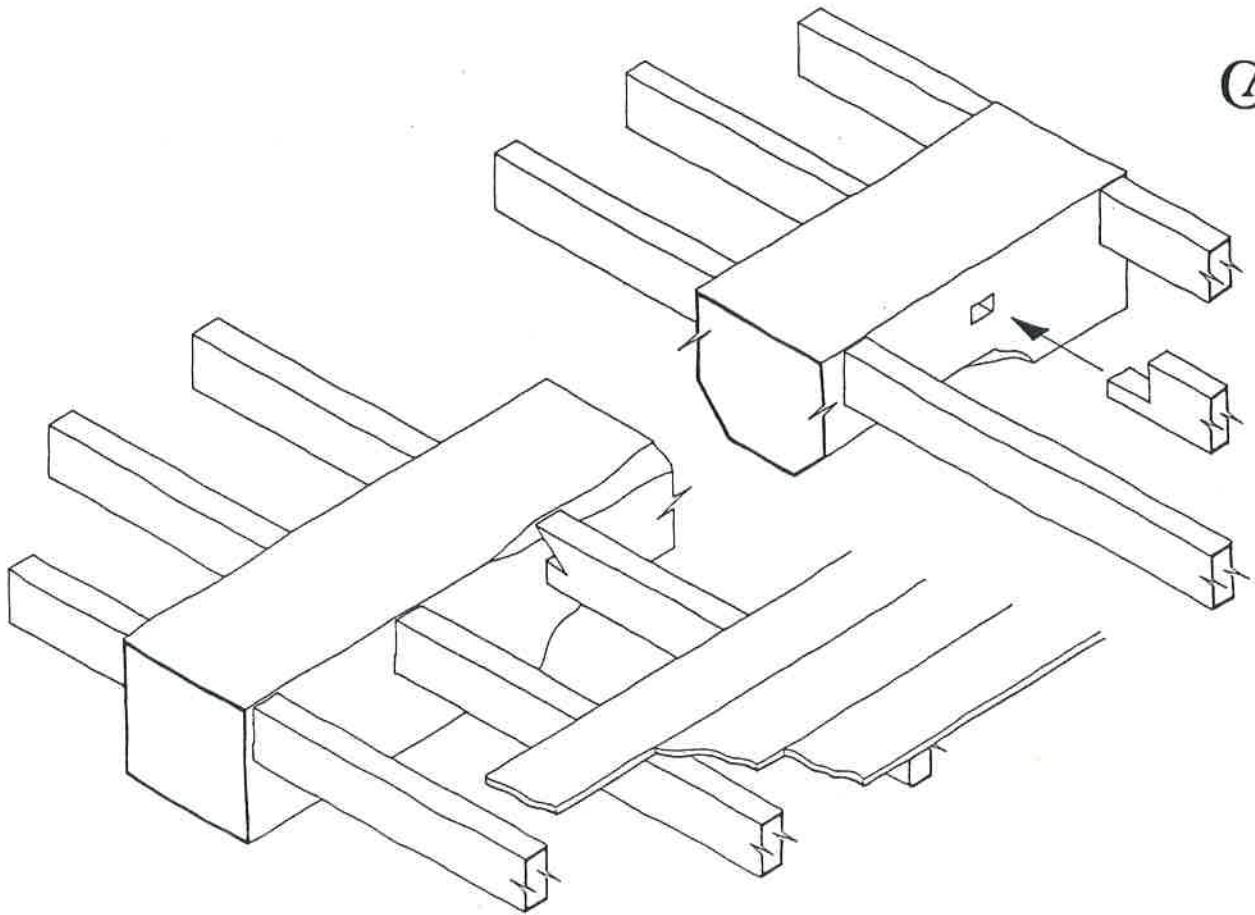
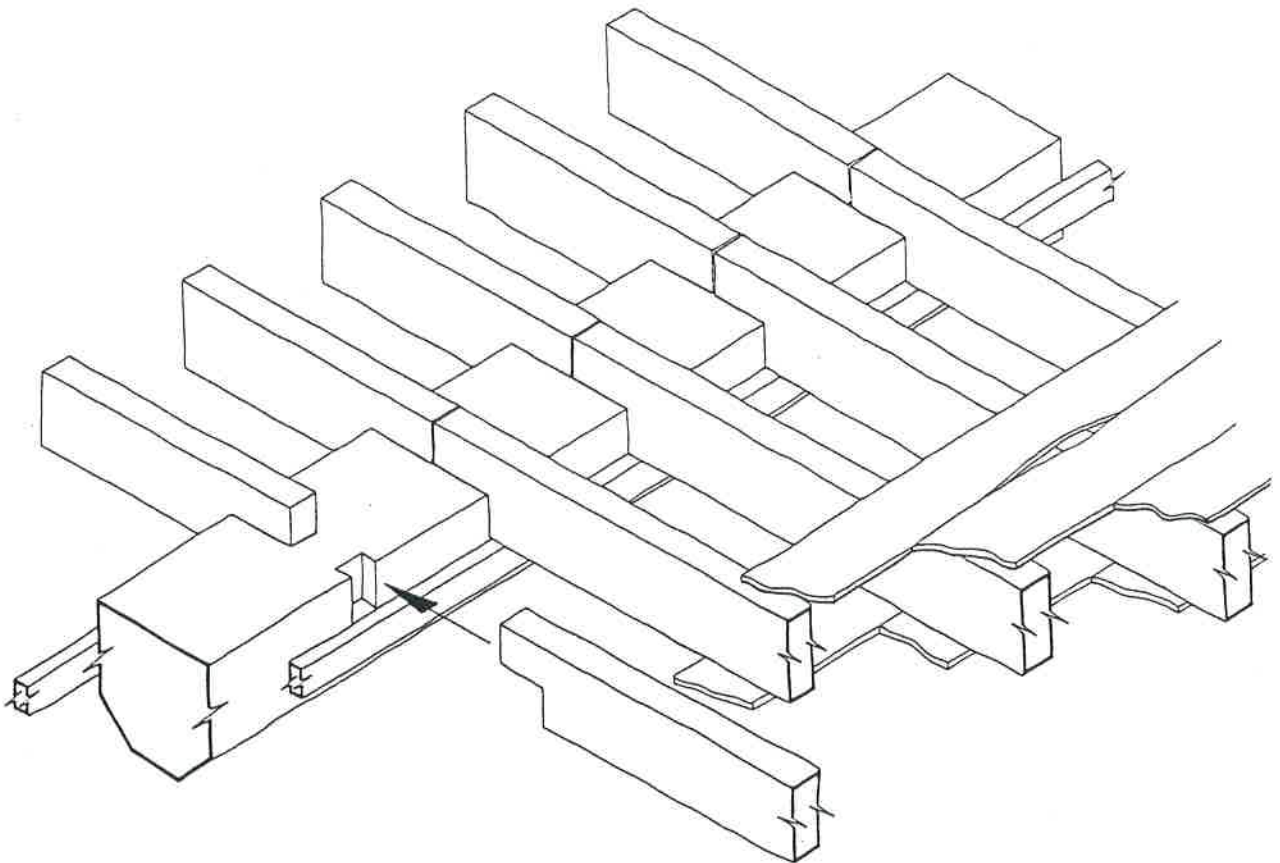
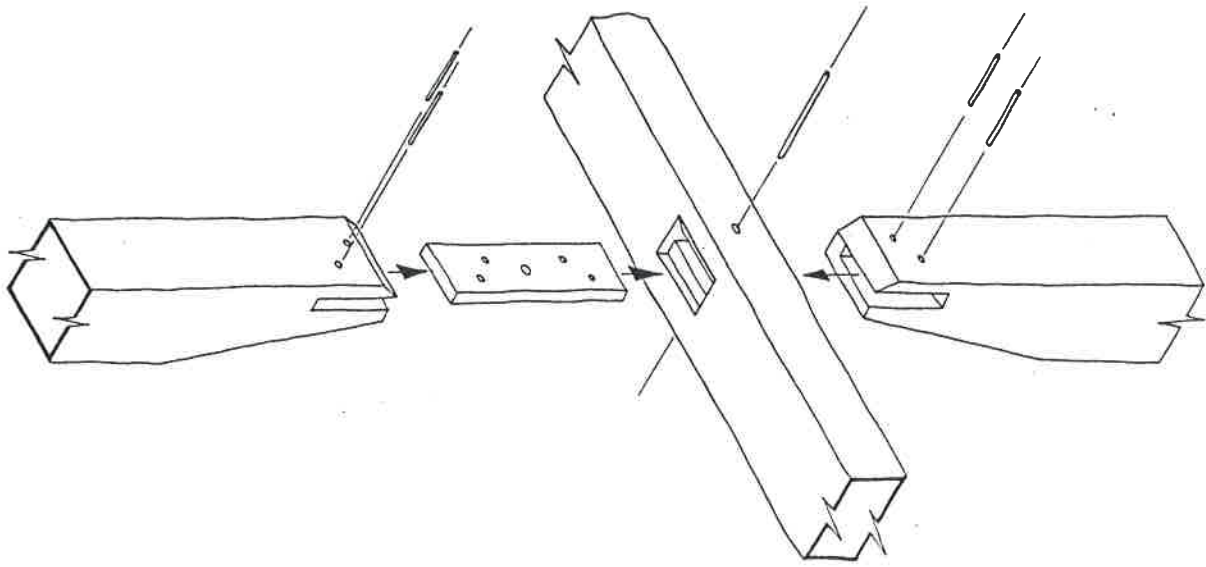
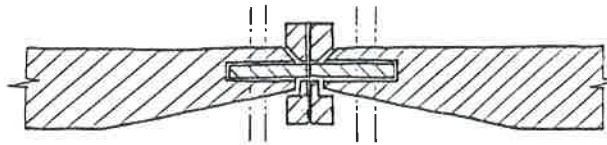
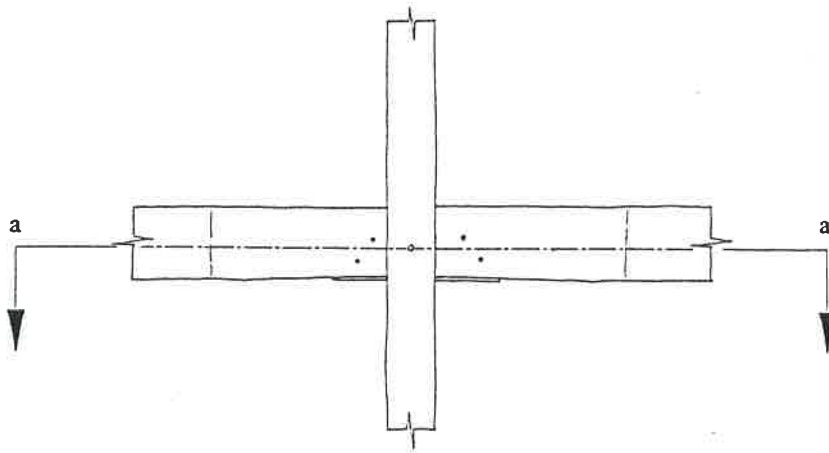

Fig.6a Stable ceiling, north end, with long and short chamfers.  
 Fig.6b Stable ceiling, south end, with replaced joists.





Isometric View



Section a-a

Fig.7 Roof detail: purlin joints to principal rafter.



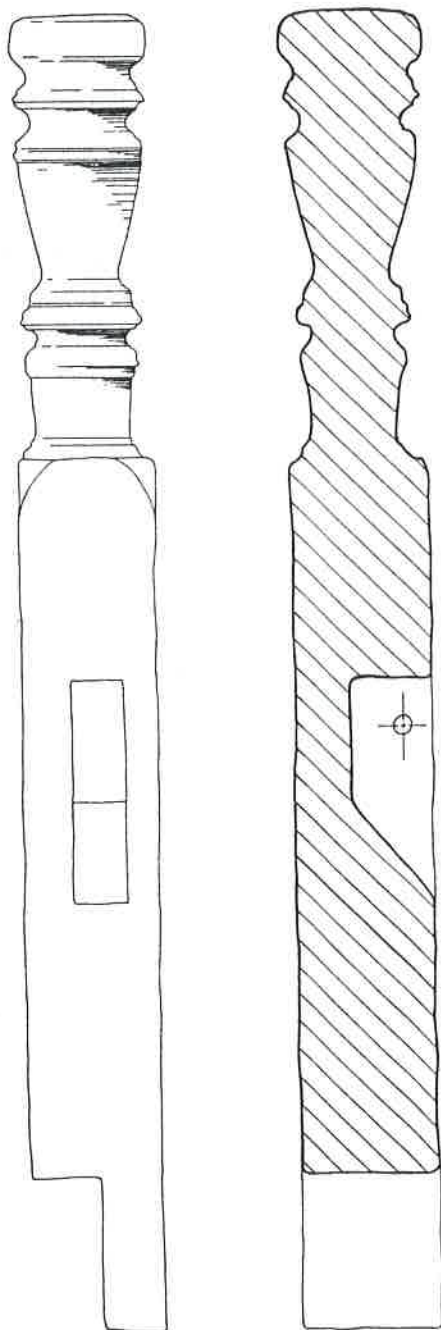

Fig.8

Brewhouse: detail of turned stair newel.



## OXFORD ARCHAEOLOGICAL UNIT

Janus House, Osney Mead, Oxford, OX2 0ES

Tel: 01865 263800 Fax: 01865 793496

email: [postmaster@oau-oxford.com](mailto:postmaster@oau-oxford.com) [www.oau-oxford.com](http://www.oau-oxford.com)



---

Director and Chief Executive: David Jennings B.A., M.I.F.A. Oxford Archaeological Unit Limited.  
Private Limited Company Number: 1618597 Registered Charity Number: 285627.  
Registered Office: Janus House, Osney Mead, Oxford OX2 0ES