

WALL

(ST)

WRYL
888/93

BIRMINGHAM NORTHERN RELIEF ROAD

CRANE BROOK, WALL
STAFFORDSHIRE

ARCHAEOLOGICAL EVALUATION

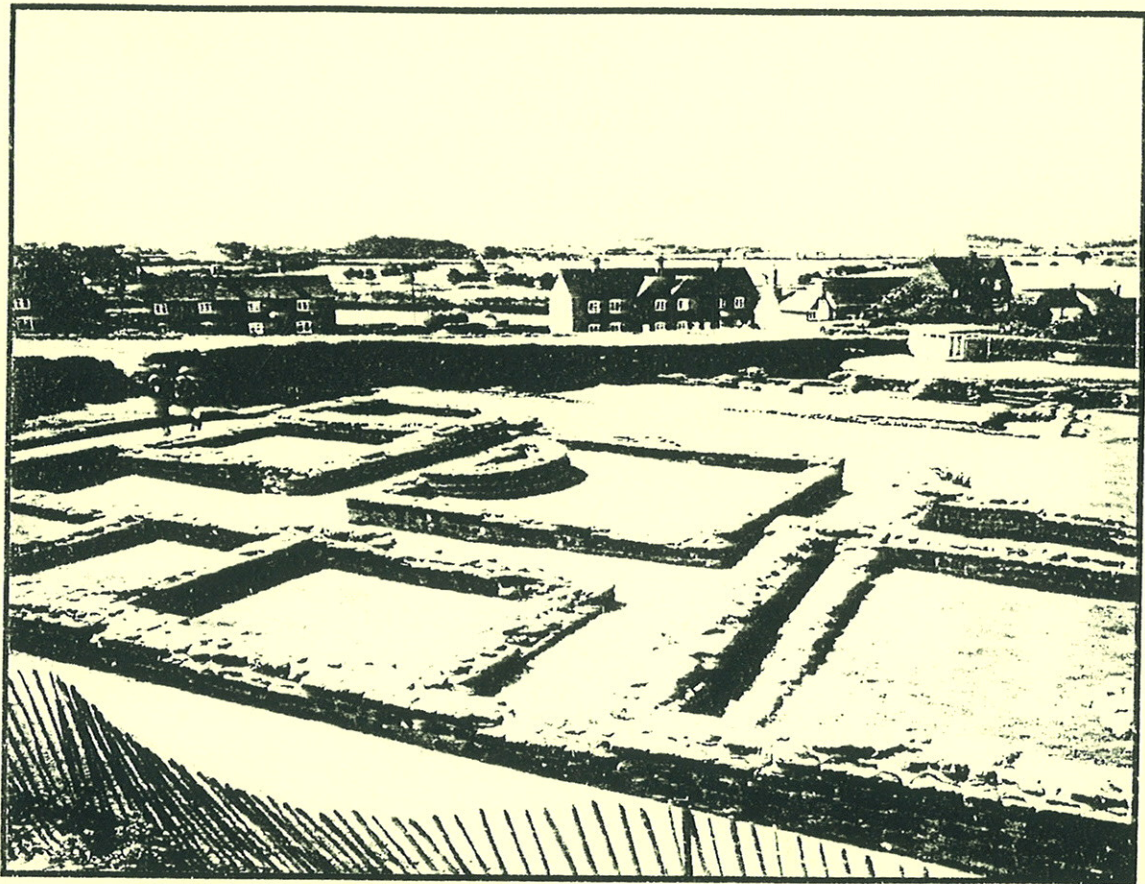

OXFORD ARCHAEOLOGICAL UNIT

March 1994

**BIRMINGHAM NORTHERN RELIEF ROAD
CRANE BROOK, WALL, STAFFORDSHIRE**

SITE CODE: WRYL93

NGR: SK094062

CONTENTS

1.	Summary	2
2.	Introduction	2
3.	Site Location and Topography	2
4.	Archaeological and Historical Background	2
5.	Objectives	4
6.	Strategy	4
7.	Summary of Results	4
8.	Trench Descriptions	5
9.	Interpretation and Discussion	8
10.	Summary and Concluding Remarks	9
Table 1:	Context Summary	10
Appendix 1:	Roman Pottery by Paul Booth	14
Appendix 2:	Environmental Evidence by Dr Mark Robinson	15
Figure 1:	Site Location; Trench Location; Cropmarks	
Figure 2:	Trench 1 plan and section	
Figure 3:	Trench 2 plan and sections	
Figure 4:	Trenches 3 and 4 plans and sections	
Figure 5:	Trenches 5, 6 and 7 plans and sections	

CM/OAU/MARCH 1994

BIRMINGHAM NORTHERN RELIEF ROAD

CRANE BROOK, WALL: ARCHAEOLOGICAL EVALUATION

1. Summary

- 1.1 The evaluation revealed a series of ditches interpreted as a hilltop enclosure which probably dates from the Late Iron Age/Early Roman period. Evidence was also recovered for what appears to be a pond or watercourse which was reclaimed during the late second/early third century AD. Other linear features have been interpreted as field boundaries and a trackway.

2. Introduction

- 2.1 An archaeological assessment was commissioned by Midland Expressway Ltd in advance of the construction of The Birmingham Northern Relief Road. The work was undertaken by the Oxford Archaeological Unit at the beginning of December 1993 in accordance with a strategy agreed with the Staffordshire County Archaeologist. The site code was WRYL93. A geophysical survey was carried out by Bartlett-Clark Consultancy in advance of trial trenching. Environmental samples were assessed by Dr Mark Robinson of Oxford University Museum.

3. Site Location and Topography (fig 1)

- 3.1 The site (centred at NGR SK094062) covered an area of c.13ha and was situated to the south of Wall which is 5 miles north of Sutton Coldfield. It consisted of two fields, separated by a small stream, and was directly across the A5 from Wall. Both fields had been chisel ploughed to a depth of up to two feet in places. The underlying geology consisted of loose white sand which overlay pink clay with gravel lenses.

4. Archaeological and Historical Background

- 4.1 The Roman town at Wall (*Letocetum*) is the most significant site of its period in Staffordshire, and includes one of only two English Heritage 'Properties in Care' in the county (the other being Croxden Abbey). This comprises the exposed walls of two Roman public buildings, the *Mansio* and Bath House, located just west of St John's Church. The complex is on the westward facing side of the low hill on which Wall stands, and has views to the west, in which the line of Roman Watling Street is marked by the now heavily trafficked A5(T) Watling Street.

- 4.2 Wall has had a very long history of antiquarian and archaeological investigations, summarised in an unpublished report by Staffordshire County Council, which was prepared in 1987 at the time of the Department of Transport's consideration of a scheme for the route. That report was the first time that the disparate existing evidence accumulated over the last 300 years had been summarised and re-appraised in any detail.
- 4.3 The core of the complex is an extensive Scheduled Ancient Monument (Staffordshire Monument No 15), of national importance, located within agricultural land around and within the village. This encompasses the remains of two known forts, the *Mansio* (official staging post and hostel) and Bath House, parts of Watling Street, the civilian settlement, various minor side roads, some paddocks and fields and possible peat deposits west of the village. Several other elements of interest outside the scheduled area can also be considered as being of national importance, for their contribution to the setting and archaeological context of the Scheduled Monument. This is particularly true of the cemeteries and main concentration of civilian settlement along Watling Street.
- 4.4 There has been a long history of archaeological investigations at Wall, mostly in the main core area of the settlement and the military forts. The southern margins of the complex south of the A5(T) Watling Street have not been very thoroughly surveyed in the past, the principal discoveries having arisen from Oswald's salvage excavations on the A5(T) (Oswald 1966-7), and some recent survey work by the South Staffordshire Archaeological Group.
- 4.5 Additional information from the South Staffordshire Archaeological Group and from examination of air photographs was accumulated for the Environmental Assessment. Six geotechnical trial pits, dug in the area between a location 500m to the west of the Crane Brook to 850m east of Ashcroft Lane, were observed and recorded archaeologically. It was not possible to carry out the surface collection survey in the area south of Wall because most of the land is under grass, and access was not granted to the one small area of arable land.
- 4.6 The main features identified in the desk top survey are as follows (fig 1):
1. A curving ditch forming part of a large oval enclosure (OAU 1052).
 2. Two widely spaced parallel ditches with a SSE-NNW alignment (part of OAU 1052 and 1158).
 3. A N-S curvilinear feature (OAU 1082).
 4. Roman occupation of the 2nd/3rd (OAU 1110) century was observed by Oswald (Oswald 1966-7) adjacent to a possible road.

4.7 Although geophysical prospecting in the area identified areas of magnetic disturbance, in general the site was not susceptible to this kind of survey.

5. Evaluation Objectives

5.1 The evaluation objectives were to examine the nature, depth, extent and quality of any archaeological deposits and to record such deposits to a high standard.

5.2 To determine the extent and nature of the cropmarks identified in the deskbased survey.

5.3 To establish the ecofactual/environmental potential of archaeological features.

6. Evaluation Strategy(fig 1)

6.1 Initially a series of 5 trenches were excavated down to the natural sand by a JCB 3CX excavator. The trenches were then cleaned by hand and investigated for archaeological activity. The position of the trenches was dictated by the location of known cropmarks and geophysical anomalies. Subsequently, a further 2 trenches were opened and investigated in order to clarify some of the archaeology identified in the initial trenching. The total sample measured 307 sq m which covered approximately 0.24% of the total area available.

7. Summary of Results

7.1 All 7 trenches contained archaeological features.

7.2 Early Roman/Native British Enclosure

7.2.1 A ditched enclosure was identified at the west end of the site. The enclosing ditch was identified in trenches 1, 3, and 7 and encircled the base of a small hillock at the extreme west of the evaluation area. One trench, Trench 2, was excavated within the confines of the ditch.

The ditch measured, at maximum, 0.80m deep by 5m wide and was filled by a complex series of overlapping deposits. Some of these deposits consisted of peat and showed evidence of a recut probably in the later 2nd Century AD according to pottery evidence. The ditch was badly truncated towards the north where it only survived to a depth of 0.20m.

The internal trench identified three badly truncated post-holes and one linear feature which contained a fragment of Roman tile. However, these features did not appear to be related.

7.3 Late 2nd/Early 3rd Century Activity

- 7.3.1 One trench, Trench 5, was opened in the field on the east bank of the Crane Brook in an area identified by Oswald in 1966 as containing 2nd Century occupation. The deposits within this trench consisted of interleaving lenses of peat and sand which contained a high concentration of Late 2nd/Early 3rd Century pottery. The deposits were contained within a shallow linear depression which was parallel to the brook. Environmental research has revealed that the deposits were not waterlain. This would appear to indicate that the material was deliberately dumped. The deposits may represent a deliberate attempt to divert the Crane Brook.

7.4 Post-Medieval Trackway

- 7.4.1 A large possible trackway was identified in trenches 1 and 6 running from north to south at the western end of the evaluation area. This was identified in the desk top evaluation as cropmark 1158. Although the upper fill of the feature contained 19th and 20th century pottery, this is likely to represent modern levelling in the field. No artefactual evidence was recovered from the primary fill. The feature measured 5m in width by at least 0.70m in depth (not fully excavated).

7.5 Field Boundaries

- 7.5.1 A north-south curvilinear field boundary was identified in trenches 2 and 6. The desk top assessment identified this feature as cropmark 1082. Datable artefacts were restricted to one fragment of Roman tile although the boundary was still in use in living memory. The feature was 1.40m wide and 0.80m deep.
- 7.5.2 A second possible boundary was identified in Trench 4. This was a very regular feature which measured 1.2m in width by 0.80m in depth. No artefactual evidence was recovered from the fill and therefore the feature cannot be dated. However the feature is very similar in nature and dimensions to the boundary described in 7.5.1 and may be part of the same field system.

8. Trench Descriptions

- 8.1.1 **Trench 1** (fig 2) measured 30m x 1.6m and had an east-west orientation. The ploughsoil, consisting of greyish brown sandy loam, measured 0.40m in depth and overlay a large curvi-linear ditch which ran along in line with the trench. The cut [008] measured 0.80m deep by 5m wide and was filled by a complex series of overlapping deposits. The primary fill [007] consisted of a thin layer of blue grey clay which formed an impermeable barrier at the base of the feature causing a 0.12m thick deposit of waterlain peat [006] to build up in the bottom of the ditch. This consisted of structured peat, c. 1% of which consisted of wood some of which was

carbonized. This material contained one sherd of Roman pottery. An 0.18m thick layer of dark grey sand [005] overlay the peat and contained 4 sherds of Roman pottery dating from the second half of the 2nd century. Subsequently the ditch was recut [015] and a second layer of peat [004] accumulated within it. This secondary waterlogging which was 0.20m thick, indicates that the ditch was in use for a substantial period of time. The ditch eventually began to silt up with 0.20m of mid grey silty sand [003] above which was 0.40m of mid-brown colluvial silt [002]. In profile the cut sloped gently but dropped vertically near the base which was slightly concave and regular.

The ditch curved around to follow the contour of the base of the hill and was also identified in trenches 3 and 7.

8.1.1 A second ditch truncated feature [008]. This consisted of a large linear cut [016] which crossed the trench obliquely from east to west and was filled with a deposit of mid brown silty sand [017]. The feature measured 5m in width and was also identified in trench 6 where it was sectioned. This feature may be the remains of a trackway which was levelled in relatively modern times.

8.2 Trench 2 (fig 3) measured 30m x 1.6m and was orientated N to S. Four features were identified beneath the topsoil in this trench.

8.2.1 Context [004]: A small circular cut in plan measuring 0.25m in diameter and 0.07m in depth. The sides were slightly concave and sloped gently to meet a regular concave base. The cut was filled with clean dark brown sand [003].

8.2.2 Context [007]: A sub-circular cut in plan measuring 0.62m in diameter and 0.15m in depth. The sides sloped gently from the surface, were slightly concave and tapered to form a U shaped base. The fill consisted of dark brown sand [006] which was overlaid by [005] grey sand.

8.2.3 Context [009]: A circular cut in plan which measured 0.20m in diameter and 0.10m in depth. In profile the sides broke sharply from the surface, were near vertical and met a flat base with a sharp break of slope. The fill consisted of clean grey sand [008].

8.2.4 Context [011]: A linear feature which crossed the southern end of the trench obliquely with a north-east to south-west orientation. Although the feature extended 3m into the trench only the north-west side was within the trench. The feature was 0.80m deep and filled with loose light brown sand [010] containing one fragment of Roman tile. This feature followed the same line as the cropmark identified as 1082.

8.2.5 All of these features were within the confines of the ditch identified in trenches 1, 3 and 7.

- 8.3 Trench 3** (fig 4) measured 30m x 1.6m and had an east to west orientation. Two features were identified beneath 0.40m of grey sandy loam topsoil.
- 8.3.1 At the west end of the trench a linear feature [003] crossed the trench from north-west to south-east. The feature was 3m wide but only had a depth of 0.10m although this area of the field had been ploughed to a depth of 2 feet and any archaeology present is likely to have been badly truncated. The fill of the feature consisted of black structured peat [002] which was identical to the primary fill of the ditch identified in trench 1.
- 8.3.2 A second linear feature [005] crossed the trench at its centre again with an north-west to south-east orientation. This feature was interpreted as a modern ploughmark.
- 8.4 Trench 4** (fig 4) measured 28m x 1.6m and had an north to south orientation. The topsoil consisted of 0.40m of loose grey sandy loam. The southern end of the trench was badly disturbed by tree holes.
- 8.4.1 Towards the northern end a linear feature crossed the trench from south-west to north-east. The cut [003] measured 1.4m in width by 0.80m in depth. In profile the cut was regular with a sharp break of slope from surface, vertical sides and a flat level base. The fill [002] consisted of moderately compact lenses of red, white and brown sand. No finds were recovered.
- 8.5 Trench 5** (fig 5) measured 17.5m by 1.6m east to west with a 7m extension taken from it at a right angle to the north. Beneath 0.30m of sandy loam topsoil was a large deposit of interleaving lenses of black amorphous peat and white sand [003]. The deposit was excavated to a depth of 0.80m in a hand dug sondage from which a total of 74 sherds of late second/early third century pottery were recovered. The feature would appear to be a backfilled pond or watercourse, or an attempt to canalise or divert the brook which is located to the south west of the trench. Environmental analysis has shown that the peat was not deposited as the result of flooding or water action but was deliberately dumped.
- 8.6 Trench 6** (fig 5) measured 12m in length by 1.6m in depth and was orientated east to west. Two linear features were identified beneath 0.30m of topsoil.
- 8.6.1 Context [004] a large linear feature measuring 5m in width by at least 0.70m in depth (not fully excavated). The fill consisted of mid brown silty sand [005] which contained 1 sherd of 19th/20th century pottery, building material and slag. This represents cropmark 1158.
- 8.6.2 Beneath [004] and heavily truncated by it was a second linear feature [002]. This consisted of a linear cut with an south-west to north-east alignment. It measured 1.4m

wide and was excavated to a depth of 0.30m (not fully excavated due to H&S restrictions). This feature probably represents cropmark 1082.

- 8.7 **Trench 7** (fig 5) measured 24m in length by 1.6m in width and had an north-west to south-east orientation. Only one feature was identified beneath the 0.40m of sandy loam topsoil. This consisted of a linear cut which ran from south-west to north-east. The feature was badly truncated by chisel ploughing which was a minimum of 2 feet deep in this area. The dimensions of the cut [003] were 2.2m in width by 0.30m in depth. The fill [002] consisted of black structured peat. This ditch was very similar in nature to, and is aligned with, the ditches identified in trenches 1 and 3 and as a single ditch would appear to have enclosed the higher ground in the field.

9. Interpretation and Discussion

- 9.1 The cropmarks identified in this area during the desktop survey were also identified during the evaluation. The cropmark identified as 1082 in the desktop survey would appear to be the linear feature identified in trenches 6 and 2. This is almost certainly a field boundary and was still in use up to around 50 years ago according to the land owners father. However, it is likely that the field division in question is a remnant of a much older feature. The only finds evidence recovered from the fill of the feature was a fragment of Roman tile, although this may be residual.
- 9.2 Cropmark 1158 was also identified. This was sample excavated in trenches 1 and 6. Finds from this feature indicate a date in the 19th or 20th century for its final levelling; no finds were retrieved from its primary fill. The feature is excessively large for a field boundary but may have been a trackway which was levelled in the early 20th century.
- 9.3 The ditch identified in trenches 1, 3 and 7 almost certainly encloses the hill. The nature of this enclosure is unknown. No evidence was recovered for internal occupation or activity other than isolated and badly truncated stakeholes. However, only one trench (Trench 2) was within the confines of the ditch. It is unlikely, therefore, that anything other than deep negative features will be preserved on the hill as this has been heavily eroded by the plough.
- 9.4 The deposits identified in trench 5 are part of an expansive process which can only be understood by more extensive trenching. It would appear, however, that the brook was modified by the inhabitants of late 2nd century Letocetum possibly to reclaim land.

10. Summary and Concluding Remarks

- 10.1 In general, therefore, although areas of the site appear to contain substantial archaeological deposits, the potential of this archaeology is minimised by the effects of erosion, mainly due to intensive ploughing and colluviation. Any internal features to the ditch would appear to have been almost completely destroyed and the ditch itself only survives to any depth at the southern extreme of the site. The field to the east side of the Crane Brook is not fully understood and requires further investigation.

Colm Moloney
Oxford Archaeological Unit
March 1994

Table 1: Context Summary

Trench 1

cxt	type	width	depth	finds	comments
1	Layer	-	0.40m	-	Topsoil
2	Layer	-	0.40m	-	Fill of 8
3	Fill	-	0.21m	-	Fill of 8
4	Fill	-	0.20m	-	Fill of 8
5	Fill	-	0.18m	-	Fill of 8
6	Fill	-	0.12m	-	Fill of 8
7	Fill	-	0.02m	-	Fill of 8
8	Cut	5m	0.80m	-	Ditch
9	Layer	-	-	-	Natural sand
10	Fill	-	0.10m	-	Fill of 8
11	Fill	-	0.20m	4 sherds of 2nd century AD Roman pottery	Same deposit as 5
12	Fill	-	0.10m	1 sherd of 2nd century AD Roman pottery	Same deposit as 6
13	Fill	-	0.02m	-	Same deposit as 7
14	Cut	-	-	-	Same cut as 8
15	Re-cut	4.50m	0.70m	-	Recut of ditch 8
16	Cut	5m	-	-	modern feature
17	Fill	5m	-	1 fragment of coal	fill of 16

Trench 2

ext	type	width	depth	finds	comments
1	Topsoil	-	-	-	-
2	layer	-	0.50m	-	ploughsoil
3	fill	0.25m	0.07m	-	fill of 4
4	cut	0.25m	0.07m	-	truncated stake hole
5	fill	0.48m	0.09m	-	fill of 7
6	fill	0.45m	0.02m	-	fill of 7
7	cut	0.62m	0.15m	-	truncated post hole
8	fill	0.17m	0.10m	-	fill of 9
9	cut	0.17m	0.10m	-	truncated post hole
10	fill	3m	0.40m	1 fragment of Roman tile	fill of 11
11	cut	3m	0.80m	-	ditch
12	fill	0.20m	0.10m	-	fill of 13
13	cut	0.20m	0.10m	-	plough mark/shallow gully

Trench 3

ext	type	width	depth	finds	comments
1	topsoil	-	-	-	-
2	fill	3m	0.10m	-	fill of 3
3	cut	3m	0.10m	-	ditch
4	fill	0.50m	-	-	fill of 5
5	cut	0.50m	-	-	gully
6	natural	-	-	-	-

CM/OAU/MARCH 1994

Trench 4

cxt	type	width	depth	finds	comments
1	ploughsoil	-	0.40m	-	-
2	fill	-	0.80m	-	fill of 3
3	cut	1.6m	0.80m	-	ditch
4	natural	-	-	-	-

Trench 5

cxt	type	width	depth	finds	comments
1	Topsoil	-	0.30m	-	-
2	cut	>4m	0.80m	-	backfilled river channel
3	fill	-	0.80m	74 sherds of assorted late 2nd century Roman pottery; 2 fragments of coal; 1 burnt quartzite fragment.	fill of 2

Trench 6

cxt	type	width	depth	finds	comments
1	Topsoil	-	0.40m	-	-
2	cut	1.30m	-	-	boundary ditch
3	fill	1.30m	-	-	fill of 2
4	cut	5m	> 1.40m	-	possible backfilled trackway
5	fill	5m	> 1.40m	1 pottery sherd-19th or 20th century. 3 frags of post-medieval tile. 2 lumps of slag. 3 frags of stone building material.	fill of 4
6	natural	-	-	-	-
7	fill	-	0.60m	-	fill of 4

Trench 7

cxt	type	width	depth	finds	comments
1	topsoil	-	0.40m	-	-
2	fill	-	0.15m	-	fill of 3
3	cut	2m	0.15m	-	ditch
4	natural	-	-	-	-

Appendix 1: Roman Pottery *by Paul Booth*

Some 79 Roman sherds were recovered from evaluation trenches on this site, 5 from trench 1 and the remainder from a single context [003] in trench 5. Most if not all the material was probably of 2nd century date.

Trench 1: A single coarse grey ware rim came from context [012], and four sherds were recovered from context [011]. These were in a soft, imperfectly reduced fabric reminiscent of that produced in a kiln excavated at Sutton Coldfield in 1986 (unpublished). If correctly identified this material is likely to date to the 2nd half of the 2nd century AD.

Trench 5: The assemblage from context [003] was quite varied. It included samian ware (4 small sherds), a colour-coated rough cast beaker, possibly from Colchester, and 5 sherds of black-burnished ware (from a single cooking pot) as well as more locally produced fabrics. Small quantities of oxidised and reduced coarse ware sherds probably came from the Mancetter-Hartshill industry, and a single white ware sherd was certainly from that source. The Sutton Coldfield kiln was possibly again represented in this group. The majority (43) of the sherds, however, were of Derbyshire ware, apparently from a single jar of typical form with a lid-seated rim.

The date of the group is suggested by the colour coated beaker fragment and by the black-burnished ware, the rim form and lattice decoration of which are unlikely to date significantly before the end of the 2nd century AD. Most of the other material in the group would be consistent with a late 2nd/early 3rd century date and there is nothing that need be earlier.

Appendix 2: Environmental Evidence *by Dr Mark Robinson*

Three potentially waterlogged samples from Roman deposits at Rymans Land, within the area of the small Roman town of Wall, were assessed for macroscopic biological remains.

The Samples

Sample 1, Trench1\cxt 6.	Black very humified peat with a little sand. Primary fill of 2nd century ditch.
Sample 4, Trench1\cxt 12.	Dark grey / black very humic sandy silt. Fill of the same Roman ditch sectioned elsewhere along its length.
Sample 2, Trench5\cxt 3.	Lenses of pinkish grey sand and dark brown humified sandy peat. Much root penetration. Regarded as late 2nd century possible fill of a river channel.

All three samples were of deposits which appeared to have experienced a severe episode of desiccation. The preservation of organic remains is very poor.

250g of each sample was broken up and soaked in water. The sample was washed over onto a 0.2mm mesh and the heavy fraction was then sieved over a 0.5mm mesh. The flots and residues were scanned under a binocular microscope.

Results

Although preservation was poor, Sample 1 was found to contain much laminated leaf cuticle and epidermal tissue. Considerable effort was made to identify this material as it was thought possible that it was waste from an industrial process of some sort. Eventually, on the basis of their margins, the leaves were tracked down as being *Ilex aquifolium*, holly. The other items identified from this sample were single specimens of the beetles *Pterostichus* sp., *Meloe* sp. and *Phyllopertha horticola*.

Sample 4 did not contain any leaf cuticle. All that could be identified were single specimens of the beetles *Agrypnus murinus* and *Aphodius* sp.

Sample 2 contained single seeds of *Sambucus nigra* (elder), *Rumex* sp. (dock) and Primulaceae indet., and two examples of the beetle *Phyllopertha horticola*.

Discussion

The ditch from which Sample 1 was taken clearly contained large quantities of holly leaves. Whether these were from the only leaves in the ditch or whether leaves from other trees or shrubs had decayed away is uncertain. Although the deposit is unusual, it need have resulted

from no more than a holly bush growing next to the ditch. The few beetles from Samples 1 and 4 suggest grassland conditions.

The deposit of Sample 2 does not appear to have been water lain. The few seeds and insects are all of terrestrial species. It has more the appearance of mixed subsoil and turf backfill, although it could have been dumped in a former channel.

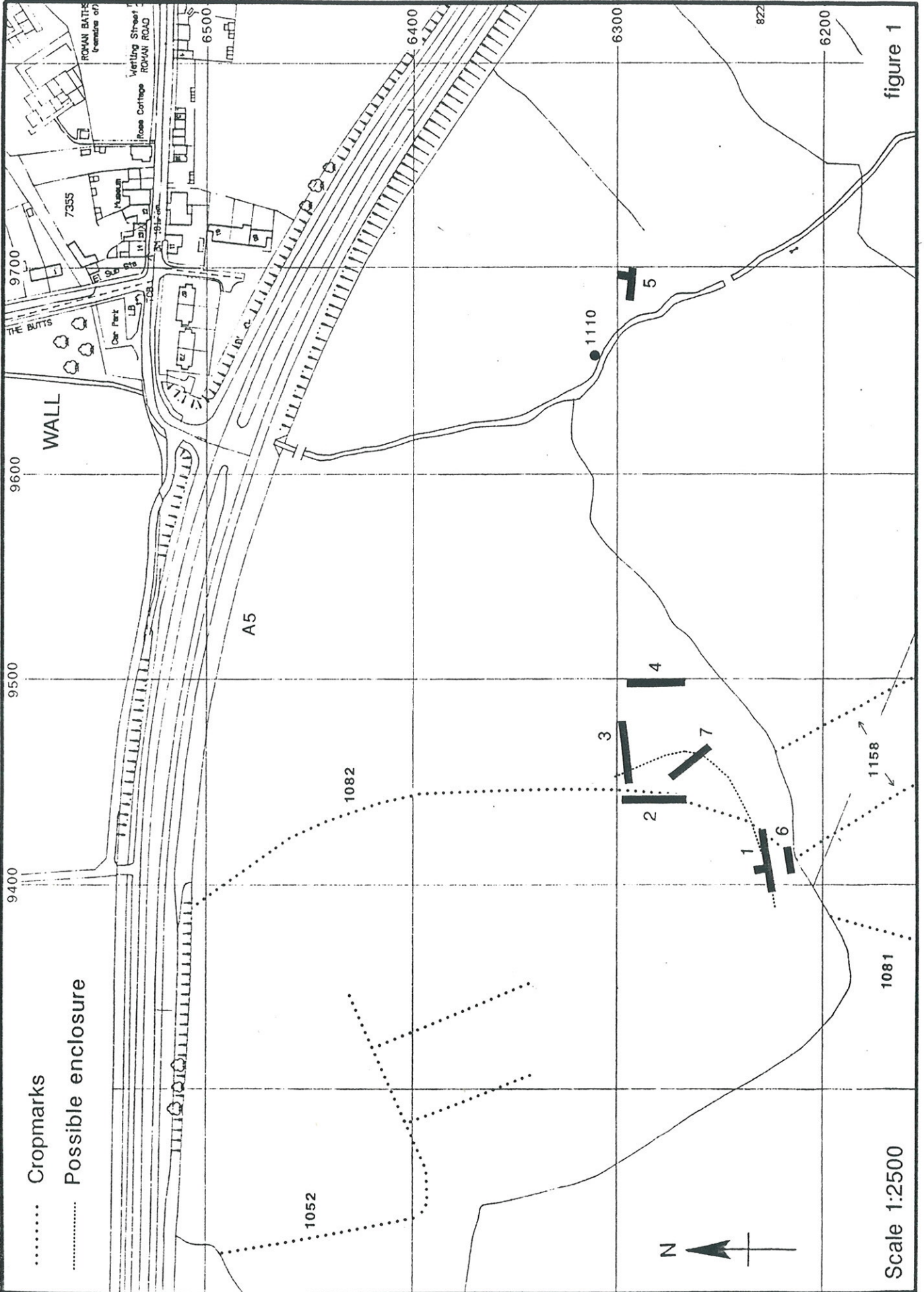
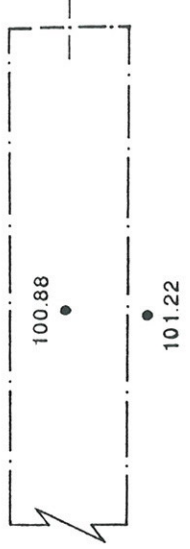
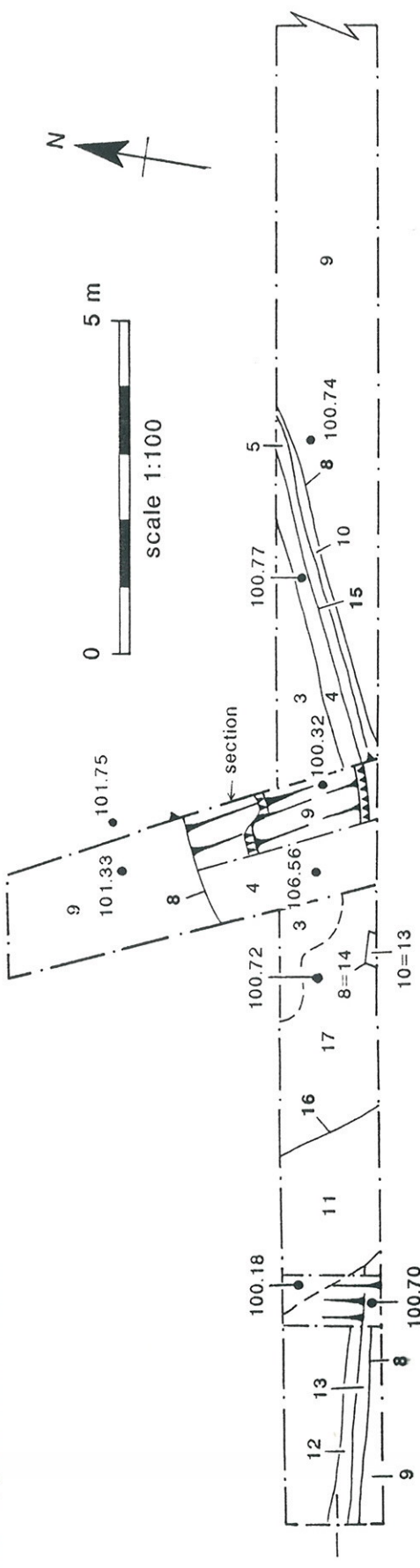

figure 1

Trench 1, plan and section



• Levels in m O.D.

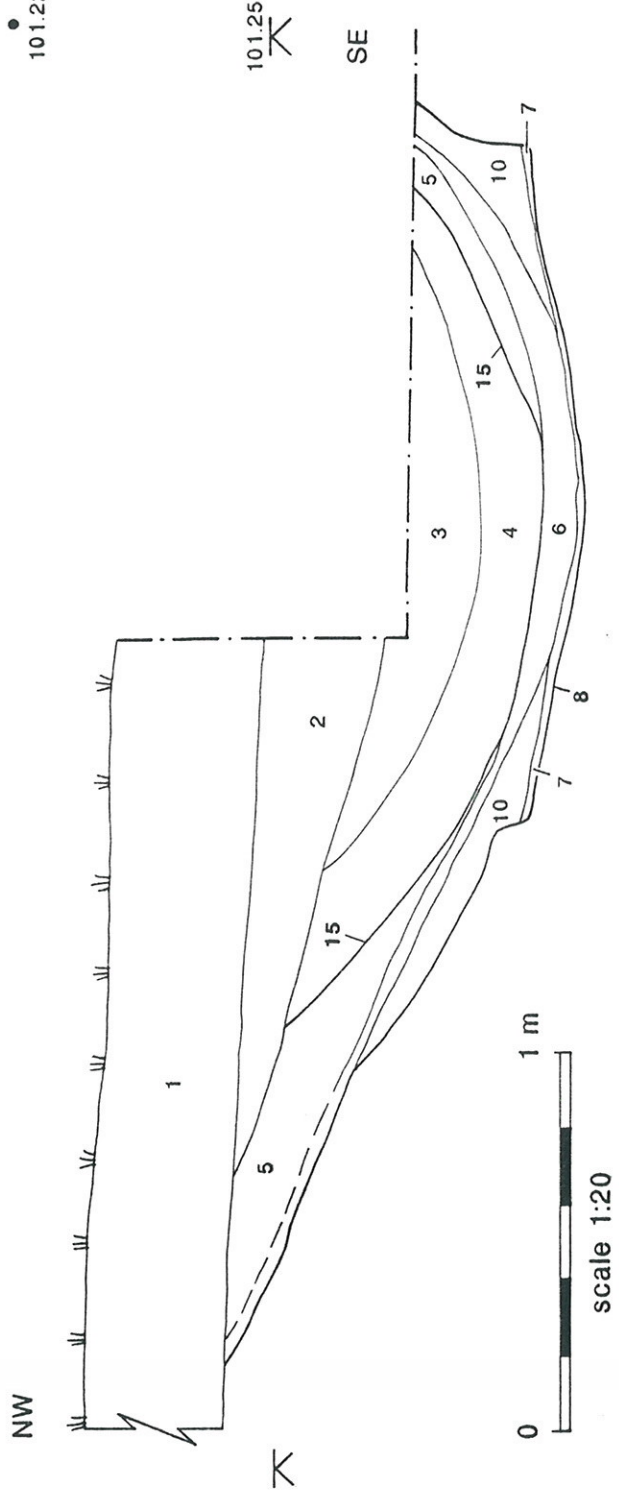
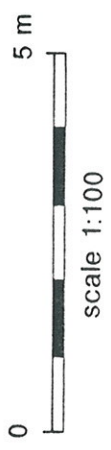
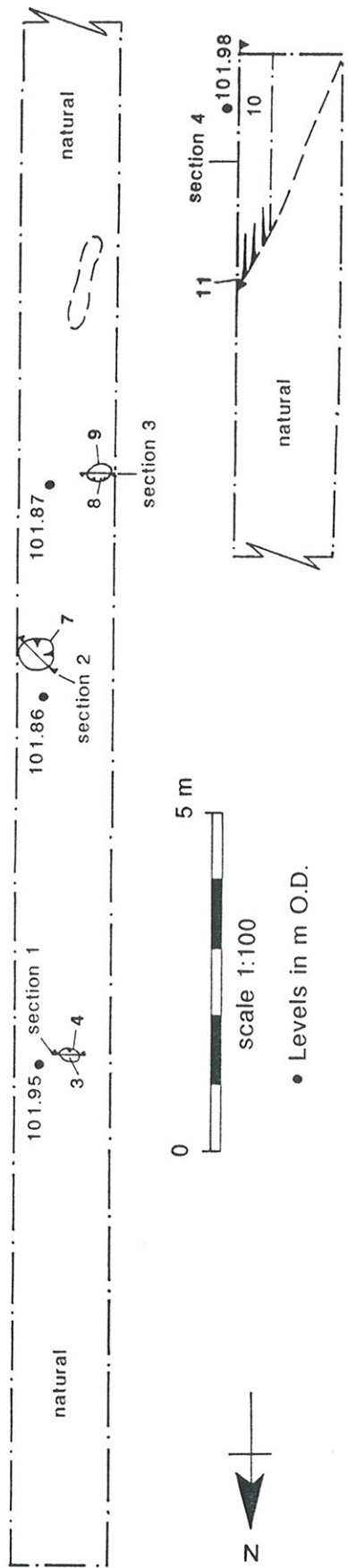

figure 2



• Levels in m O.D.

Section 1



Section 2

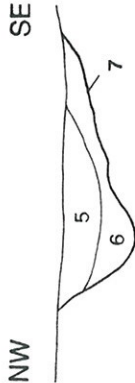

Section 3



Section 4

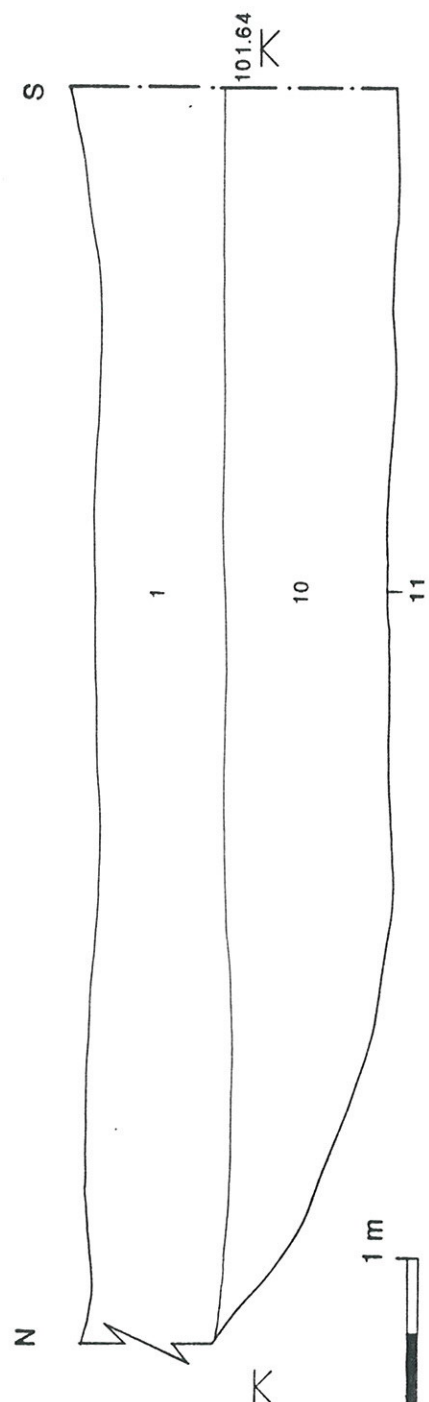
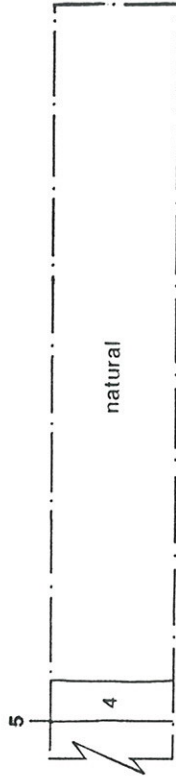
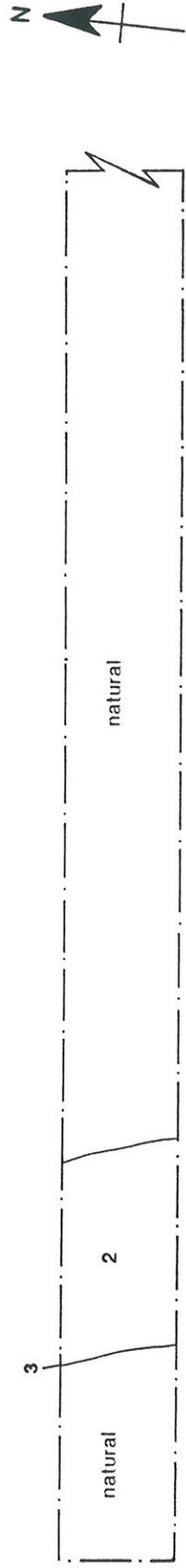

figure 3

Trench 3, plan



0 5 m
scale for plans 1:100

Trench 4, plan and section

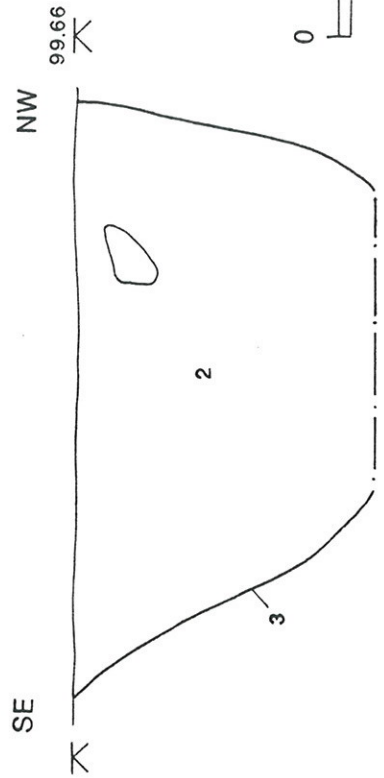
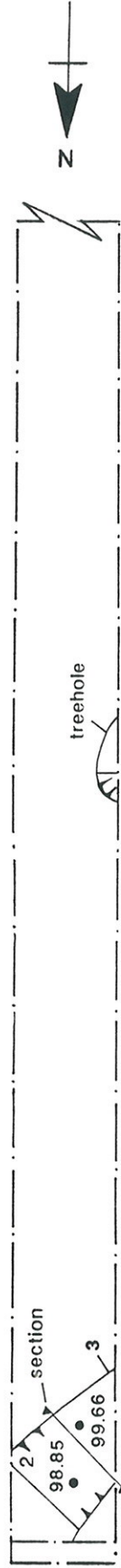

• Levels in m O.D.

0 1 m
scale 1:20

figure 4

Trench 5, plan

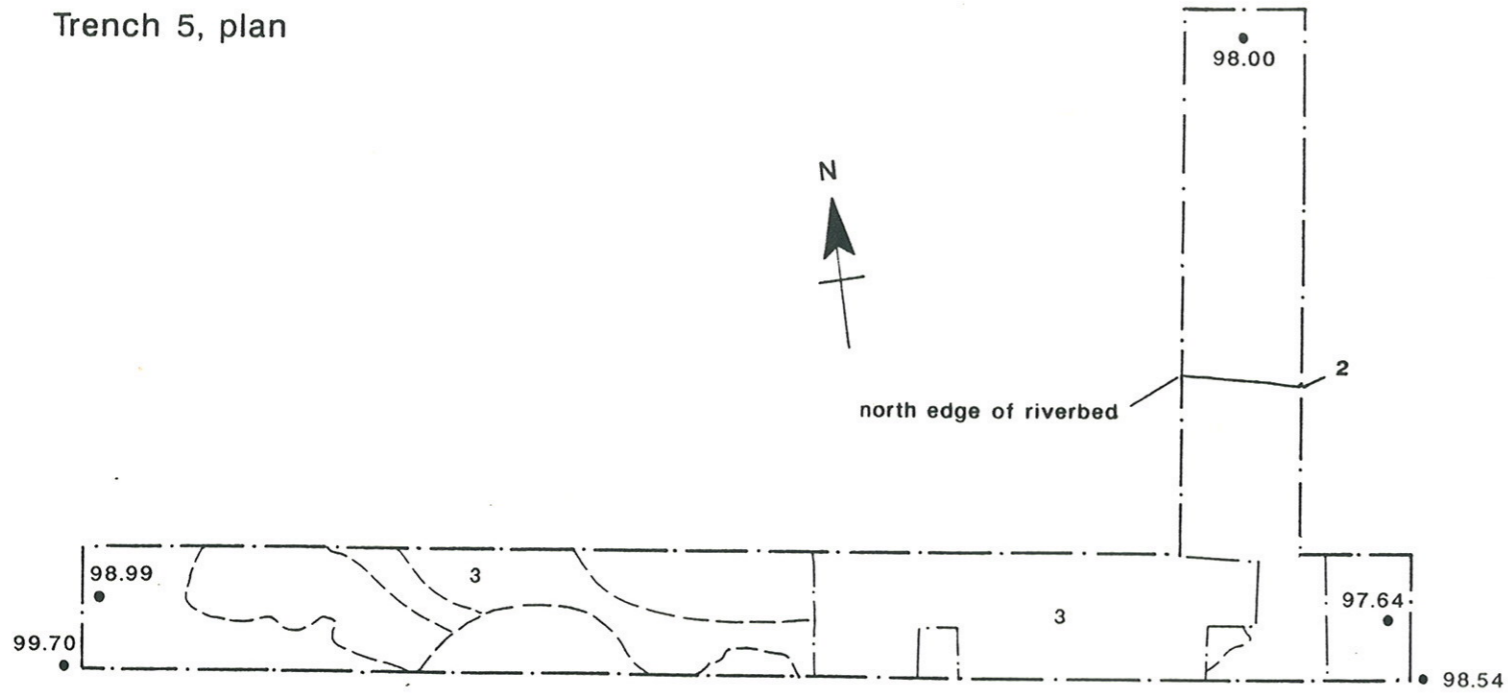

Trench 6, plan and section

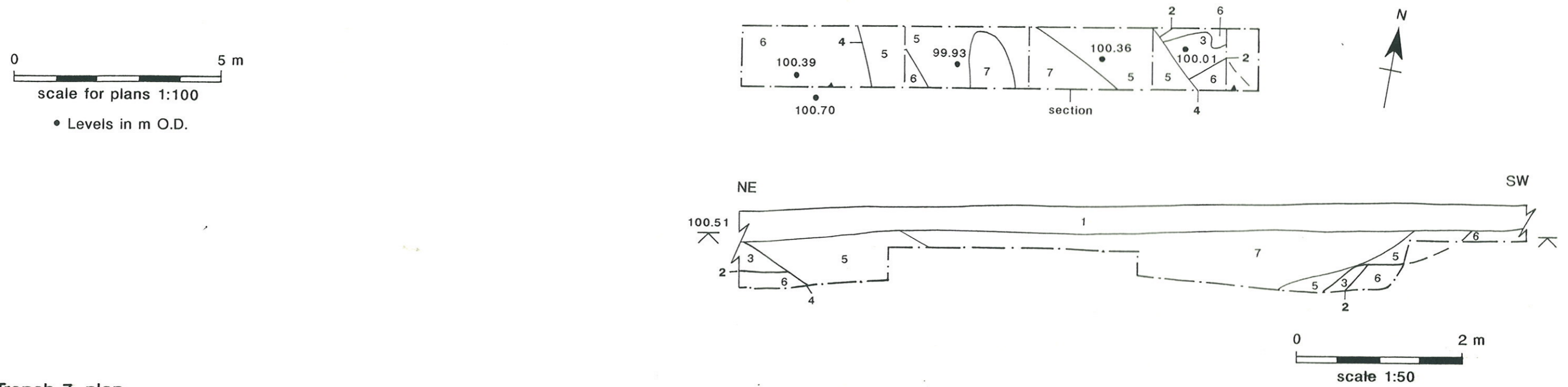

Trench 7, plan

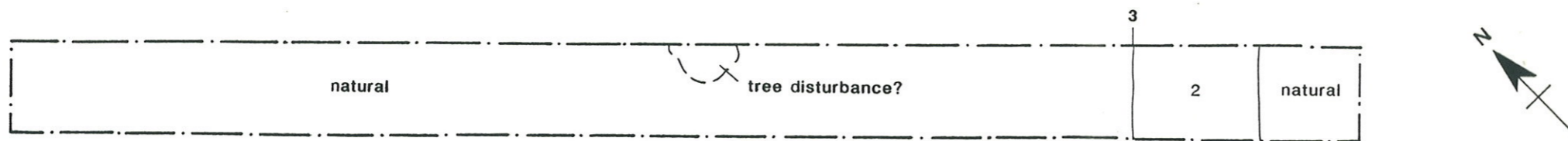

figure 5

Oxford Archaeological Unit
46 Hythe Bridge Street
Oxford OX1 2EP



Tel: 0865 243888 Fax: 0865 793496

Registered Charity No. 285627
Private Limited Company No. 1618597