

OFFICE COPY.

LIBRARY COPY

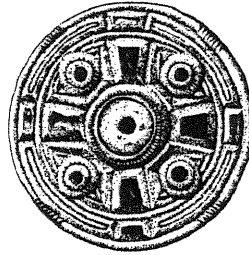

Archaeological Field Unit

British Sugar Factory, Oundle Road, Peterborough:
An Archaeological Evaluation

Scott Kenny

1998

Cambridgeshire County Council

Report No. A137

Commissioned By Stirling Maynard and Partners on behalf of British Sugar Plc

**British Sugar Factory, Oundle Road, Peterborough:
An Archaeological Evaluation**

Scott Kenny

1998

Editor: Tim Malim BA
Illustrator: Jon Cane BA

Report No A137

©Archaeological Field Unit
Cambridgeshire County Council
Fulbourn Community Centre
Haggis Gap, Fulbourn
Cambridgeshire CB1 5HD
Tel (01223) 881614
Fax (01223) 880946

SUMMARY

Between 8th and 19th June 1998, the Archaeological Field Unit of Cambridgeshire County Council (AFU) carried out an archaeological evaluation on land at the British Sugar factory, Oundle Road, Peterborough (TL180/977). The work was commissioned by Stirling Maynard and Partners Ltd, on behalf of British Sugar Plc and in advance of proposed residential development.

Despite the wealth of SMR references in the surrounding area and on the site itself, archaeology was found in only two of the trenches and test pits excavated. All of the features excavated produced little in the way of finds, the only datable piece being a single sherd of medieval pottery from Trench 12. The lack of finds overall suggests that this might be intrusive. The features found in this evaluation are not typical of a particular period, and at the present time they cannot be securely dated.

The evaluation has indicated that few archaeological remains survive in the areas that have been extensively developed over the last sixty years, however there is the potential for greater survival beneath the roads on the site. These may not have been moved, and thus would protect any archaeology sealed beneath.

TABLE OF CONTENTS

1. INTRODUCTION	1
2. GEOLOGY AND TOPOGRAPHY	3
3. ARCHAEOLOGICAL AND HISTORICAL BACKGROUND	3
3.1 General Archaeological Background	3
3.2 Archaeology and History of the Development Site	6
4. METHODOLOGY	8
5. RESULTS	10
6. DISCUSSION	14
7. RECOMMENDATIONS	14
ACKNOWLEDGEMENTS	15
BIBLIOGRAPHY	15

LIST OF FIGURES

Figure 1 Site Location Map	1
Figure 2 Archaeological Background	2
Figure 3 Trench Location Plan	9
Figure 4 Plan of Trenches containing archaeological features with accompanying sections	12

British Sugar Factory, Oundle Road, Peterborough: An Archaeological Evaluation

1 INTRODUCTION

Between 8th and 19th June 1998, the Archaeological Field Unit of Cambridgeshire County Council (AFU) carried out an archaeological evaluation on land at the British Sugar factory, Oundle Road, Peterborough (TL180/977). The work was commissioned by Stirling Maynard and Partners Ltd, on behalf of British Sugar Plc, and in advance of proposed residential development. The commission was in response to a brief set by the Peterborough City Council Archaeological Service (PCCAS).

Before the field evaluation phase, a desktop study was carried out as part of an Environmental Assessment prepared in advance of development. The study assessed the archaeological potential of the site, situated on the southern bank of the River Nene on the south-western edge of the city of Peterborough.

The study area is approximately 53 hectares centred on grid reference TL180/977, is currently occupied by British Sugar Plc and has been since construction of factory buildings in the 1920s (Figure 1).

Archaeological remains have been recovered from the site, the most notable being a possible Bronze Age cremation, Iron Age settlement evidence, Roman pottery and coins, and an Anglo-Saxon burial ground. It was considered likely by the PCCA that archaeological remains might still survive on the site and the evaluation was intended to test this hypothesis.

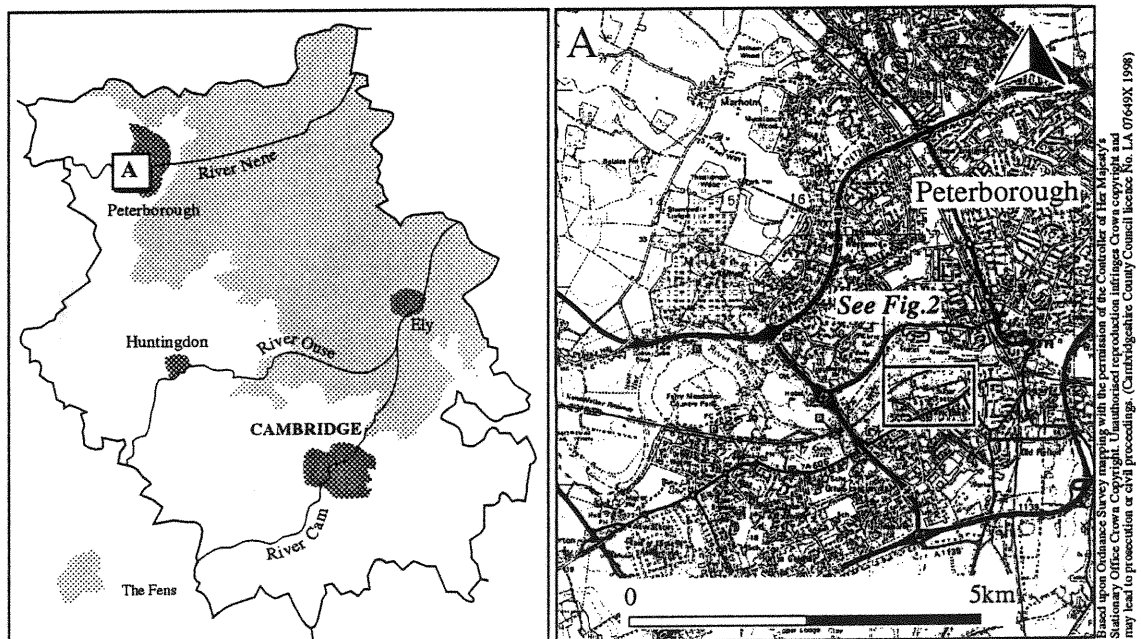

Figure 1 Location Map

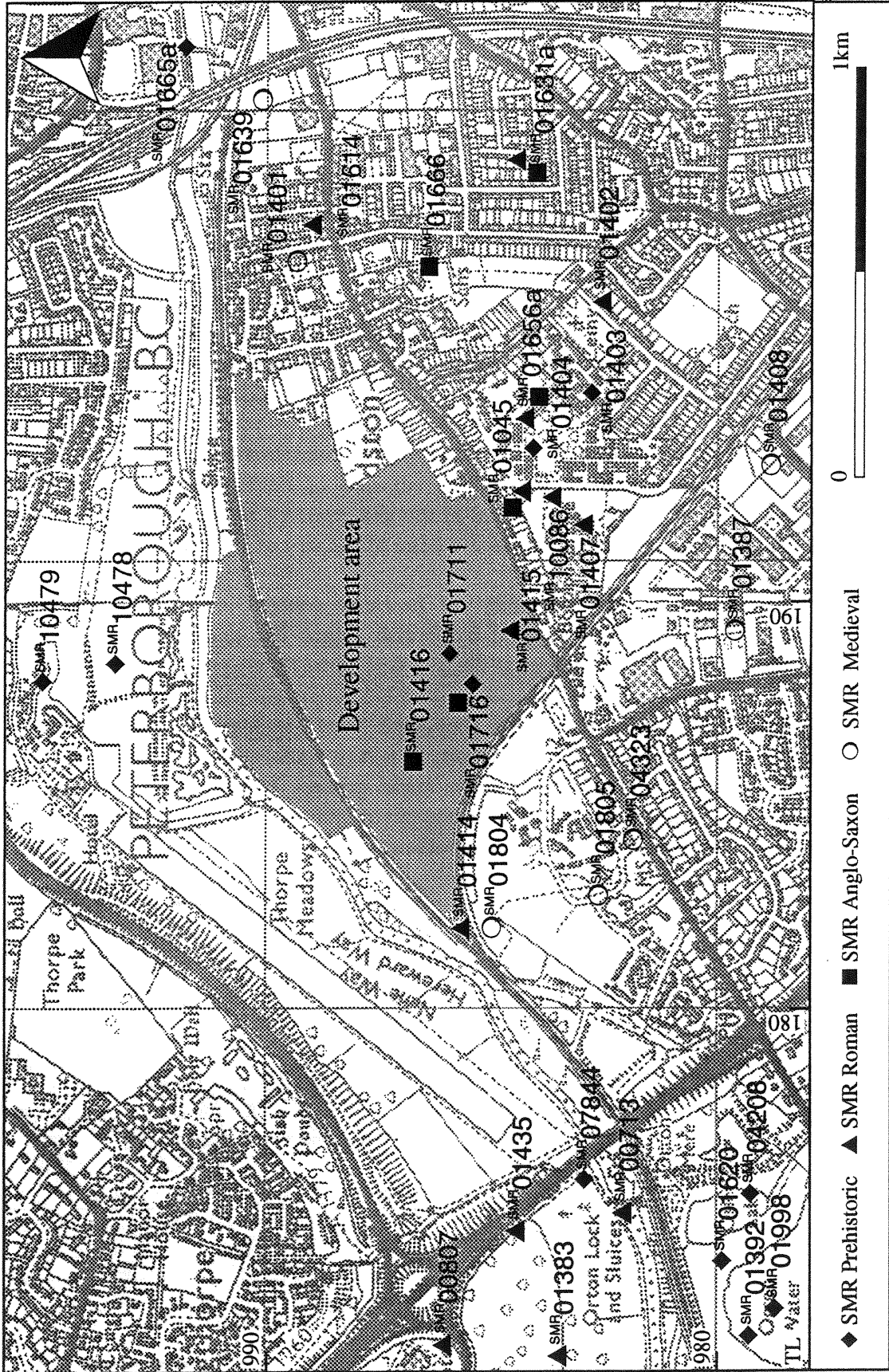

Figure 2 Archaeological background: Cambridgeshire Sites and Monuments Record

2 GEOLOGY AND TOPOGRAPHY

The site is generally low-lying, and adjacent to the river is at less than 5m, rising gently to the south east with a height of 11m to 13m on Oundle Road. The site has been considerably altered by construction of lime pits and settling tanks, and levelling associated with the construction of the factory from 1925 onwards. The low-lying land in the north and north-east of the site has been subject to flooding in the recent past.

The underlying geology of the site comprises river alluvium, from the Nene, overlying Lower Lincolnshire Limestone with a 'seam' of Cornbrash running parallel to the river in the northern part of the site, with overlying Kellaway Clays and Second River Terrace deposits in the south-eastern part of the site

3 ARCHAEOLOGICAL AND HISTORICAL BACKGROUND

3.1 General Archaeological Background (Figure 2)

Early prehistoric

It would appear from recorded finds that the Nene valley around Woodston was occupied during the Palaeolithic period. The bulk of remains are concentrated on the higher 2nd terrace gravels to the south of the river Nene.

Palaeolithic axes and a Palaeolithic occupation floor (Cambridgeshire Sites and Monuments Record no. 1656a) were reportedly found in 1910 approximately 300m to the south east on the terrace gravels, at a height over approximately 12m OD. Other Palaeolithic tools are recorded (SMR nos. 1356, 1645) in the vicinity, again on the higher land, but not close to the site.

Neolithic remains are more widespread than earlier prehistoric evidence, having been found on both sides of the River Nene. These occur mainly as isolated finds of flint tools (arrowheads). More substantial remains, in the form of burial mounds, have also been noted in the vicinity. No settlement evidence is recorded in the area around Woodston.

Neolithic huts and settlement remains (SMR no. 1656) together with prehistoric flint tools (SMR no. 1403) were found during the early part of the 20th century on the gravels to the south but no closer to the site than 300m. Flints, probably Neolithic (SMR no. 1412), are also recorded on the gravels to the south. Other prehistoric stone tools are recorded to the north of the river. These are reportedly Neolithic, mainly arrowheads, perhaps lost whilst hunting birds and animals close to the river. Burial mounds of possible Neolithic date (SMR nos. 1620, 1392) are recorded to the south-west of the site.

Bronze Age

It has been suggested by Fox (1923) that there was widespread occupation of the Nene valley during the Bronze Age (2nd millennium BC). Bronze Age urns with overhanging rims have been discovered at Fletton, to the east of the site (collection in the Peterborough Museum). Remains from this period have also been found on the proposed development site (see below).

Bronze Age remains have been noted to the west of the site, on the southern bank of the River Nene. Barrows or burial mounds (dated to the Neolithic/Bronze Age period) (SMR nos. 1392 and 1620) have been located on low-lying land to the north of Orton Longueville and a Bronze Age axe (SMR no. 1998) was found in the same area. Nearer to the site, but on the northern bank of the river a Middle Bronze Age palstave is recorded (SMR no. 7844)

It would thus appear that Bronze Age occupation in this area was concentrated close to the river in spite of the land being relatively low-lying.

Iron Age

Iron Age use of rivers from the Wash to the Fen are well attested and associated with continental Iron Age influence (Fox, 1923). Early Iron Age pottery ('Late Hallstatt' type according to Fox) has been found in abundance near Peterborough.

Other than the Iron Age settlement excavated on the development site (see below) there appear to be few Iron Age remains reported in the immediate vicinity. An Iron Age farm has been recorded close to the Roman fort at Longthorpe and Iron Age coins have been found on the northern bank of the River Nene, opposite the site (SMR nos. 10479 and 10478). An Iron Age boat is recorded to the east, adjacent to the present crossing place of the Nene (SMR 1665). Iron Age remains (SMR no. 4208) have been excavated on the south bank of the Nene, to the west of the site, in association with the earlier burial mounds mentioned above.

Roman

Extensive Roman remains have been found in the Nene Valley and in the area surrounding the development site at Woodston. The well documented fort of Longthorpe (Scheduled Ancient Monument 135) with an associated Iron Age farm lies less than 1km to the west of the site, on the north bank of the Nene. Roman occupation remains have also been found just south of the river. A fording place (SMR no. 4321) is known adjacent to the fort.

Roman remains (mainly burials, coins and rubbish pits) have been found to the south of the site, particularly on the 2nd terrace gravels south of Oundle Road.

Anglo-Saxon

Saxon occupation of the area around Woodston is well documented. There were settlements (SMR nos. 1631, 1656) on the 2nd terrace gravels to the south of the site and Anglo-Saxon buildings (SMR no. 1806) were excavated 1km to the south-west at Orton Longueville. Anglo-Saxon cemeteries have

also been found in the vicinity (SMR nos. 1382 (in Longthorpe fort), 1045 and 1666). Far fewer Anglo-Saxon remains have been located to the north of the river Nene. An Anglo-Saxon monastery is recorded to the east of the site (SMR no. 1518), also on the south bank of the river. Anglo-Saxon burials from the site are discussed below.

Medieval

Medieval development of Woodston was linked to trade and transport, together with an agricultural base. The village was able to benefit from a position close to the river and on a major east-west route, just south of the medieval town of Peterborough. The manor of Woodston was given by King Edgar (959-975) to Bishop Ethelwold of Winchester who then gave it to the Abbey of Thorney which held it until the Dissolution of the Monasteries (Victoria County History 1974). Remains of the pre-Conquest church of St. Augustine (mentioned in the Domesday survey) have been incorporated into the present church at Woodston. The Domesday Survey in 1068 refers to the fact that Thorney Abbey held five hides (a measurement of agricultural land) at Woodston whilst the King held a further five hides at Bottolbridge (Hart 1968) to the south-west.

The Deserted Medieval Village of Botolph Bridge (also known as Bottlebridge or Botuleuesbrige) has been located immediately to the south-west (SMR no. 1805). Botolph Bridge formed a separate parish, with its parish church of St. Mary Botolphbridge (SMR no. 1804) to the west of the development site. A bridge spanned the river between Woodston and Orton Longueville (Hart 1966, 108), at Botolph Bridge and it is known that Botolph Bridge was an embargement point on the Nene for the transport of stone from quarries beyond Alwalton along the fen waterways to towns such as Cambridge. There is a record for the slating of Corpus Christi College Cambridge (during the 14th century) which mentions tollage at Bottlebridge (Butler, 1957, 89-100). The toll house, now demolished (SMR no 4323), was on Oundle Road to the west of the site.

Woodston was used as a landing place for goods coming by river from the west to Yaxley, thus avoiding tolls at Peterborough. In 1268 the Abbot of Thorney was granted a weekly market, on a Wednesday, and he obtained at much the same time the right to hold a fair. A windmill is mentioned in records of 1279 (VCH 1974) and a fishery was appurtenant to the manor of Woodston during the reign of Edward I.

The documentary evidence points to a considerable settlement which appears to have been concentrated along Oundle Road and northwards along the street (Wharf Road) towards the river, to the east of the site. Further settlement was centred at Botolph Bridge, to the west of the site. The presence of ridge and furrow agriculture is evident in the form of earthworks and cropmarks in the vicinity.

During the medieval period nearby Peterborough was a major town with dense medieval occupation to the north of the river. Activity was initially centred

around the monastic settlement and market but grew considerably during the medieval period.

Post-medieval

Eayre and Jeffrey's map of Northamptonshire in 1779 shows the small rural settlement of Woodstone strung along the Oundle Road towards Overton Longville (now Orton Longueville) and continuing eastwards and northwards along a road leading to the river, to the east of the present site. The parish was inclosed under a local Act of Parliament in 1809 and the Inclosure map of 1811 shows the village concentrated along Wharf Road and its junction with Turnpike Road (Oundle Road). The road appears at this time to have followed a slightly different route just beyond the south-western corner of the development site.

The 1885/7 Ordnance Survey Map shows a similar settlement pattern with the bulk of the village lining Wharf Road, with allotments behind the houses to the east of the site, but with several houses and the Cross Keys public house along Oundle Road near Woodston Hill. The railway is also in place by this time. The number of properties along the road increases slowly, as can be seen on the Ordnance Survey maps of 1900, 1901, 1924 and 1926. This latter map shows the initial construction of the sugar factory, see below.

Modern land use in the area includes housing with their associated gardens and allotments along the major routes. By the late 19th/early 20th century the Nene Valley railway ran east-west, roughly parallel to the river, with a junction to the north of the DMV of Botolph Bridge and with a further line running along the western part of the site. Lime kilns and mineral extraction have also been widespread in the area and occurred on the subject site. The mid-20th century saw an expansion in industry and housing development to the south of the river and the former parish of Woodston has now been incorporated into the city of Peterborough.

3.2 Archaeology and History of the Development Site (Figure 2)

Known Archaeological Remains

During the early part of this century a shallow pit containing burnt human bone and ashes together with five unburnt beads of Kimmeridge shale and an inverted Bronze Age collard urn (SMR no. 1716a) were found within the later Anglo-Saxon cemetery on the western part of the site immediately north of Woodston Hill.

An Iron Age settlement (SMR no. 1711) was found during gravel extraction on the site during the early part of the 20th century (the extent of the gravel quarries can be seen on the 1900 and 1926 Ordnance Survey maps). The remains consisted of a quantity of pottery together with burnt flint and animal bones found in a series of pits. The pits were grouped: 1m - 2m in diameter and 2m - 3m in diameter and were described as 'huts' but were more probably

storage pits. Such settlement sites are known to extend over several acres. Three or four extended inhumations were found nearby.

Pottery (SMR no. 1414) in the north-western part of the site was found before 1934 following dredging of the River Nene and included Roman types, including Nene Valley wares and Samian, and human and animal bone. A Roman building was excavated, in the late 1980s, in the vicinity of Botolph Bridge DMV church, and it is possible that Roman settlement in this area could extend eastwards onto the site. Roman coins (SMR no. 1415) have been recovered from the southern part of the site.

Excavations have been carried out on the site from the early 19th century onwards. Pagan Anglo-Saxon burials were discovered in 1828 during gravel digging but most of the finds from the Anglo-Saxon period were made after 1886. Controlled excavation took place in the south-western part of the site (SMR no. 1416 and 1716) in the 1920s by G. Wyman Abbot. These find spots, in former quarries, may represent a cemetery which extended for at least 200m. A further find of Anglo-Saxon skeletons to the south of the site (SMR no. 1045) might also be part of the same cemetery suggesting that burials may occur over an area of some 500m, perhaps a cemetery with a series of different foci. This scenario would be very similar to known examples at Lakenheath and Eriswell in Suffolk. A further cemetery is reported from Fletton and it is possible this could have extended onto the east of the development site, in the area of the present allotment gardens

No finds have been reported from disturbance connected with construction work associated with the British Sugar factory site during the second part of the 20th century. Monitoring of the site was carried out by Peterborough Museum staff and members of the Nene Valley Research Committee.

Medieval and post-medieval land use

Medieval and post-medieval land use maps show an area of open land and allotments on the site. To the south-west of the site the area is occupied by the DMV (Botolph Bridge) between Woodston and Orton Longueville, close to the river, with a route running to a possible crossing place. It is possible that the medieval village extended onto the south-western part of the British Sugar site itself. Most of the area on the northern part of the site is low-lying, and liable to flooding. This area was divided into small fields at the time of inclosure in 1809. Settlement developed on the higher ground to the south, along Oundle Road, during the 19th and early 20th century.

The Ordnance Survey Map of 1885/1887 shows the position of quarries and a lime kiln in the north-western part of the site. Deposits of 2nd Terrace gravel were extensively exploited in Woodston and are known to have been extracted from the site from the early part of the 19th century.

Twentieth century land use

In the early part of the 20th century the western part of the site appears to have been in the hands of two owners, Mr G Martin and Alderman Hunting, and was

parcelled into several fields to the rear of the houses along Oundle Road. It would appear that most of this land was used for agriculture. Considerable excavation for foundations, lime and settling pits has been carried out since the first factory was built on the site in 1925/6. The factory continued to expand with further groundworks in the early 1950s, 1970s and 1980s. The railway line with the Longueville junction was in place at this time and continued in use throughout the period when the British Sugar factory was in use. Sidings crossed the site to various factory buildings.

The 1900 Ordnance Survey map shows sand and gravel pits on the site of the present sports field. The 1925/26 Ordnance Survey map shows a quarry to the north of Woodston Hill (the discovery site of Anglo-Saxon burials and other finds) which is now beneath part of the factory.

4 **METHODOLOGY**

Before the commencement of work on site, the desktop study previously mentioned was undertaken to ascertain the full extent of known archaeological data for the site. A geophysical survey, as outlined in the brief, was considered unlikely to be effective, due to the local geology and likely extensive disturbance (Noel, pers. comm.). An aerial photographic survey and replotting was considered unlikely to yield results additional to those revealed previously (Palmer, pers. comm.). The desktop study revealed extensive information about the historical and archaeological background of the site, the results of which are largely detailed above.

Areas of the site were targeted for intrusive evaluation according to both archaeological potential and accessibility; the latter being a consideration due to the continued use of the site by British Sugar and others. Certain areas could not be investigated at this time, but might be available for observation during construction.

Eighteen trenches and test pits were opened using a mechanical excavator with a 1.8m toothless ditching bucket, under the supervision of an archaeologist (see Fig.3). All of the test pits had been intended to be excavated as linear trenches, but were aborted for reasons detailed below.

The trenches were cleaned by hand where appropriate, photographed, and base planned using a Zeiss RecElta 15 Total Station Theodolite with an internal data logger. The survey data was downloaded to, and manipulated in AiC's ProSurveyor v3.35, and the resulting drawings plotted.

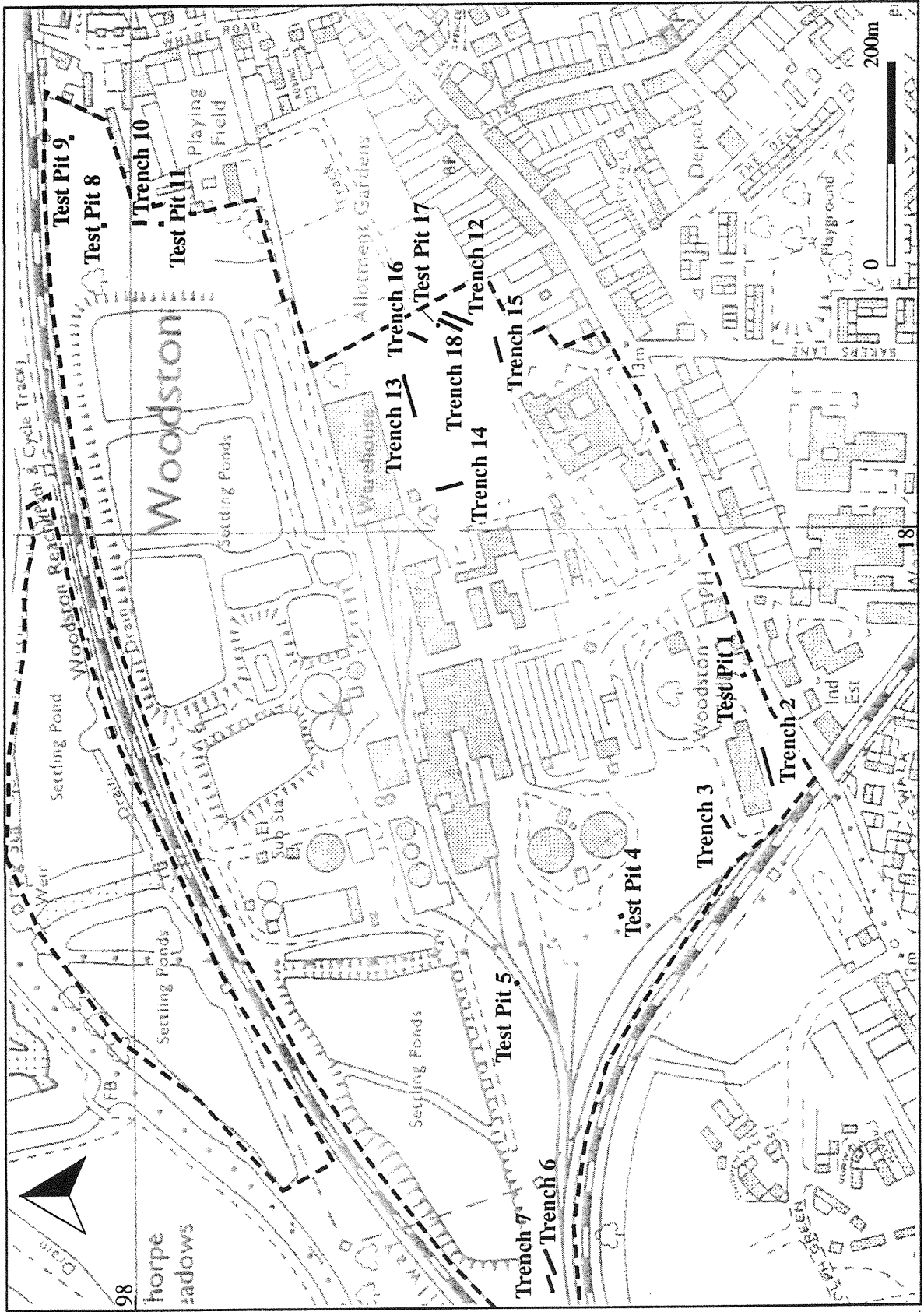

Figure 2 Trench location plan showing extent of development area (dashed line)

5 RESULTS (See Fig 3 for trench locations)

Test Pit 1, Trench 2 and Trench 3 were located to test the area around Woodston Hill, site of several SMR entries.

5.1 Test Pit 1

Test Pit 1 was 2m long and contained no archaeology. 0.25m of turf and topsoil overlay at least 0.95m of makeup. The trench was aborted at this length and depth due to encountering a service trench.

5.2 Trench 2

Trench 2 was 39m long and contained no archaeology. 0.25m of turf and topsoil overlay a maximum of 0.8m of makeup; below this was natural silty clay.

5.3 Trench 3

Trench 3 was 13.5m long and contained no archaeology. 0.15m of topsoil overlay 2.0m of lime and rubble; below this was natural silty clay. The trench was aborted at this length and depth due to safety restrictions.

Test Pit 4 was located to test an apparently undisturbed area northeast of Botolph Bridge.

5.4 Test Pit 4

Test Pit 4 was 3m long and contained no archaeology. 0.15m of topsoil overlay 1.7m of lime and rubble; below this was natural silty clay. The trench was aborted at this length and depth due to safety restrictions.

Test Pit 5 was located to test the area just south of one of the Anglo-Saxon cemeteries.

5.5 Test Pit 5

Test Pit 5 was 3m long and contained no archaeology. 0.15m of topsoil overlay 2.2m of lime and rubble; below this was natural silty clay. The trench was aborted at this length and depth due to safety restrictions.

Trenches 6 and 7 were located to test the area north of Botolph Bridge and the Roman settlement.

5.6 Trench 6

Trench 6 was 24m long and contained no archaeology. 0.10m of topsoil overlay natural gravel.

5.7 Trench 7

Trench 7 was 16m long and contained no archaeology. 0.15m of topsoil overlay at least 1.0m of debris and soil, including railway sleepers and sections of brick wall. It was abandoned due to possible contamination, and partially backfilled.

Test Pit 8, Trench 10 and Trench 11 were located in an apparently undisturbed area to the west of Medieval Woodston. Test Pit 9 was intended to test the area close to Wharf Road.

5.8 Test Pit 8

Test Pit 8 was 3.5m long and contained no archaeology. 0.25m of silty topsoil overlay 0.9m of makeup; below this level were silty clay deposits containing the remains of reed beds. The trench was aborted at this length and depth due to safety restrictions.

5.9 Test Pit 9

Test Pit was 2.5m long and contained no archaeology. 0.25m of topsoil overlay at least 1.7m of very modern makeup, at the base of which was found a "Crunchie" wrapper of a type not seen before 1990. The trench was aborted at this length and depth due to safety restrictions.

5.10 Trench 10

Trench 10 was 12.5m long and contained no archaeology. 0.25m of turf and topsoil overlay at least 2.0m of makeup. The trench was aborted at this length and depth due to safety restrictions.

5.11 Test Pit 11

Test Pit 11 was 3m long and contained no archaeology. 0.25m of turf and topsoil overlay at least 2.4m of makeup. The trench was aborted at this length and depth due to safety restrictions.

Trenches 12, 13, 14, 15, 16, 18 and Test Pit 17 were all located in a fairly blank patch, devoid of SMR entries, ranged around the known gravel extraction pit in the centre of the sports field.

5.12 Trench 12 (See Fig.4)

Trench 12 was 29m long and contained five linear archaeological features. 0.25m of turf and topsoil overlay a maximum of 0.5m of subsoil/makeup.

From south to north, the features were:

Cut 5 was a straight linear feature running approximately east-west, butt-ending within the trench. It contained two fills, 3 and 4. The upper fill, 3 was a very dark grey sandy clay silt, and the lower fill, 4, was a dark brown clay sandy silt. No finds were recovered from either fill.

Cut 7 was a straight linear feature running approximately east-west. It contained a single fill, 6, a dark yellowish brown sandy silty clay, from which a single sherd of probable medieval shelly ware, and animal bone was recovered. The latter included the only major find on the

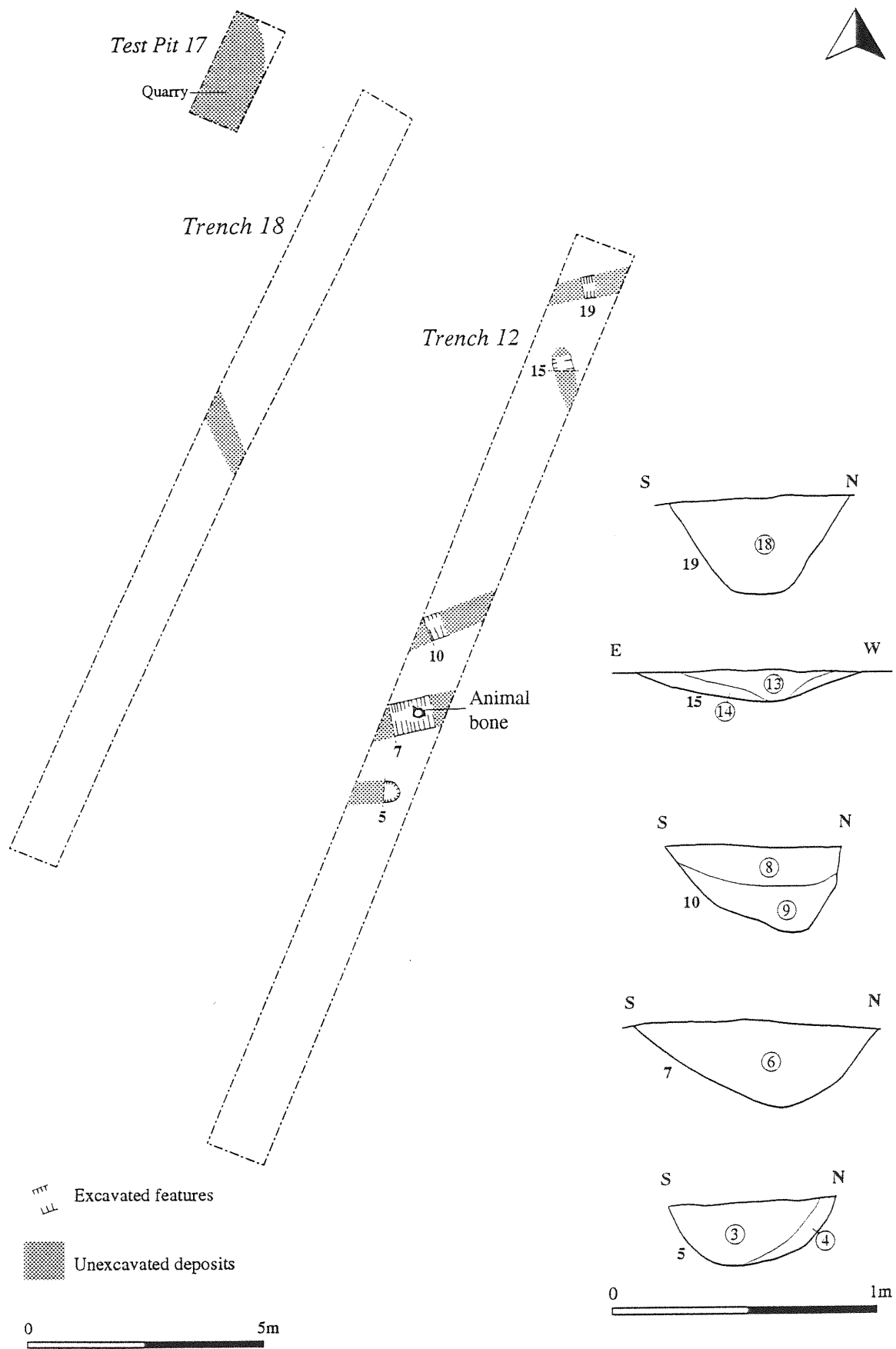

Figure 4 Plan of Trenches containing archaeological features with accompanying sections

site, an intact pelvis of a young adult horse. It was discovered on the base of the cut, seemingly placed there with some care. Two waste flakes of worked flint and a single piece of burnt flint were also recovered from the fill.

Cut 10 was a straight linear feature running approximately east-west. It contained two fills, 8 and 9. The upper fill, 8 was a very dark grey sandy silty clay, and the lower fill, 9, was a dark yellowish brown clayey sand and gravel. No finds were recovered from either fill.

Cut 15 was a straight linear feature running approximately north-south, butt-ending within the trench. It contained two fills, 13 and 14. The upper fill, 13 was a very dark grey clay sandy silt, and the lower fill, 14, was a dark yellowish brown clay sandy silt. No finds were recovered from either fill.

Cut 19 was a straight linear feature running approximately east-west. It contained a single observed fill, 20, a dark brown sandy clay silt, from which no finds were recovered.

Below all these features was natural silty clay and sandy gravels.

5.13 Trench 13

Trench 13 was 41m long and contained no archaeology. 0.20m of turf and topsoil overlay a maximum of 0.3m of subsoil/makeup; below this was natural silty clays and sandy gravels.

5.14 Trench 14

Trench 14 was 25m long and contained no archaeology. 0.15m of turf and topsoil overlay natural sand and gravel.

5.15 Trench 15

Trench 15 was 23m long and contained no archaeology. 0.20m of turf and topsoil overlay a maximum of 0.4m of subsoil/makeup; below this was natural silty clay and sandy gravels.

5.16 Trench 16

Trench 16 was 19m long and contained no archaeology. 0.20m of turf and topsoil overlay a maximum of 0.35m of subsoil/makeup; below this was natural silty clay.

5.16 Test Pit 17 (See Fig.4)

Test Pit 17 was 3m long and contained no archaeology. 0.25m of turf and topsoil overlay 0.4m of makeup. The trench was aborted at this length and depth due to encountering the edge of quarrying.

5.16 Trench 18 (See Fig.4)

Trench 18 was 25m long and contained a single archaeological feature. 0.25m of turf and topsoil overlay a maximum of 0.5m of makeup.

Cut 21 was a straight linear feature running approximately north-south. It contained a single observed fill, 20, a dark yellowish brown sandy silty clay, which was not excavated. Below this was natural silty clay.

6 DISCUSSION

Despite the density of SMR entries indicating artefacts of various periods found in the surrounding area, the evaluation revealed archaeology in only two of the eighteen trenches and test pits. Artefacts of various dates were recovered from the subsoil in a further trench. All of these trenches with archaeological remains were in the Sports Field. The features excavated were all relatively narrow linears of a similar depth (Fig.4), with the exception of 15, which was very shallow, but had similar fills to another feature in the same trench. These features might represent small enclosures, but without a single physical or stratigraphic relationship between them, it is difficult to infer dimensions or arrangement. The single datable sherd from fill 6 could be intrusive and cannot in itself be said to date the feature.

In other areas of the site, near to Botolph Bridge (Fig.2), earthmoving to build the banks of settling tanks has removed topsoil and subsoil, and possibly some natural, obliterating any features that might have existed there. Closer to the factory, the process of dumping lime and rubble, presumably into disused settling tanks, has also removed any trace of archaeology. In the northeastern part of the site, modern dumping, compounding the practice of dumping beetwash, has built the ground up considerably since the 1920's. Before this date, evidently it was subject to periodic flooding, and must have at one time been marsh, in order for the reedbed to have formed. On the southern side of the site, no evidence could be found relating to the Anglo-Saxon cemeteries previously excavated there (Fig.2), but this may still be preserved under the roadways which cannot yet be removed due to the site's continued use.

If the roadways and areas of hard standing/car parks have remained in largely the same places during the lifetime of the site, then these are the areas which will probably have the least intrusive effect upon any underlying archaeology which survives. This would then make them a priority for further observation during development, in particular the area around Woodston Hill, which is at present largely concreted over.

7 RECOMMENDATIONS

It is potentially possible, despite the largely negative results of the evaluation, that isolated pockets of archaeology survive within the development area. These would only be revealed during demolition and/or construction, and thus a scheme of monitoring and observation of these works would help to record any further discoveries in this archaeologically sensitive area. In those areas where it has been demonstrated that large scale earthmoving and infill has taken place in the recent past, it is unlikely that remains will be found. Any monitoring will have to prioritise areas which stand a chance of archaeological remains surviving, such as those mentioned in the previous section.

ACKNOWLEDGEMENTS

The author wishes to thank British Sugar for funding the project, and Stirling Maynard and Partners for commissioning it, particularly David Hall, the Project Manager; Tim Malim, the Project Manager for the Archaeological Field Unit; the site staff- Carole Fletcher. Thanks are also due at both the SMR and at the County Records Office. Dr Mark Noel provided advice on the potential success of geophysical survey; Rog Palmer provided advice on aerial photographic replotting. This project was carried out in response to a brief drawn up by the Peterborough Archaeology Officer, Ben Robinson.

BIBLIOGRAPHY

Cambridgeshire and Peterborough Sites and Monuments Record (SMR)

- Fox, C , 1923 *The Archaeology of the Cambridgeshire Region*,
Cambridge University Press
- Butler, L A S, 1957 *Medieval Gravestones of Cambridgeshire,*
Huntingdonshire and the Soke of Peterborough,
Proceedings of the Cambridgeshire Antiquarian
Society, Vol L, 89-100
- Hart, C, 1966 *The Church of St. Mary Huntingdon*, Proceedings of
the Cambridgeshire Antiquarian Society, Vol LIX,
108
- Hart, C, 1968 *The Hidation of Huntingdonshire*, Proceedings of
the Cambridgeshire Antiquarian Society, Vol LXI,
55-66
- Page, W, Proby, G
& Inskip Ladds, S
(eds.) 1974 *A History of the County of Huntingdon*, Vol III, The
University of London Institute for Historical
Research



Cambridgeshire
County Council

Archaeology

The Archaeological Field Unit
Fulbourn Community Centre
Haggis Gap
Fulbourn
Cambridge CB1 5HD
Tel (01223) 881614
Fax (01223) 880946