

# LAKESIDE, SCUNTHORPE, NORTH LINCOLNSHIRE



## Archaeological Evaluation and Palaeoenvironmental Assessment



**Oxford Archaeology North**

February 2006

**John Samuels Archaeological  
Consultants**

Issue No: 2005-6/480  
OA North Job No: L9580  
NGR: SE 9165 0826  
Planning Reference: 2202/1407

**Document Title:** LAKESIDE, SCUNTHORPE, NORTH LINCOLNSHIRE

**Document Type:** Archaeological Evaluation and Palaeoenvironmental Assessment

**Client Name:** John Samuels Archaeological Consultants

**Issue Number:** 2005-6/480  
**OA North Job Number:** L9580  
**Site Code:** LSS05  
**National Grid Reference:** SE 9165 0826

Prepared by: Jeremy Bradley Elizabeth Huckerby  
Position: Project Officer Environmental Manager  
Date: November 2005 January 2006

Checked by: Stephen Rowland Signed.....  
Position: Project Manager  
Date: January 2006

Approved by: Alan Lupton Signed.....  
Position: Operations Manager  
Date: February 2006

**Oxford Archaeology North**

Storey Institute  
Meeting House Lane  
Lancaster  
LA1 1TF  
t: (0044) 01524 848666  
f: (0044) 01524 848606

w: [www.oxfordarch.co.uk](http://www.oxfordarch.co.uk)  
e: [info@oxfordarch.co.uk](mailto:info@oxfordarch.co.uk)

**© Oxford Archaeological Unit Ltd (2006)**

Janus House  
Osney Mead  
Oxford  
OX2 0EA  
t: (0044) 01865 263800  
f: (0044) 01865 793496

Oxford Archaeological Unit Limited is a Registered Charity No: 285627

**Disclaimer:**

*This document has been prepared for the titled project or named part thereof and should not be relied upon or used for any other project without an independent check being carried out as to its suitability and prior written authority of Oxford Archaeology being obtained. Oxford Archaeology accepts no responsibility or liability for the consequences of this document being used for a purpose other than the purposes for which it was commissioned. Any person/party using or relying on the document for such other purposes agrees, and will by such use or reliance be taken to confirm their agreement to indemnify Oxford Archaeology for all loss or damage resulting therefrom. Oxford Archaeology accepts no responsibility or liability for this document to any party other than the person/party by whom it was commissioned.*

## CONTENTS

---

<b>SUMMARY .....</b>	<b>3</b>
<b>ACKNOWLEDGEMENTS.....</b>	<b>4</b>
<b>1. INTRODUCTION.....</b>	<b>5</b>
1.1 Circumstances of the Project .....	5
<b>2. BACKGROUND.....</b>	<b>6</b>
2.1 Site Location, Topography and Geology .....	6
2.2 Archaeological and Historical Background.....	6
2.3 Previous Archaeological Work.....	8
<b>3. METHODOLOGY.....</b>	<b>9</b>
3.1 Written Specification .....	9
3.2 Evaluation Trenching.....	9
3.3 Palaeoenvironmental Assessment.....	10
3.4 Archive.....	11
<b>4. RESULTS.....</b>	<b>12</b>
4.1 Trench 1 .....	12
4.2 Trench 2 .....	12
4.3 Trench 3 .....	13
4.4 Trench 4 .....	13
4.5 Trench 5 .....	14
4.6 Trench 6 .....	14
4.7 Trench 7 .....	15
4.8 Trench 8 .....	15
4.9 Trench 9 .....	16
4.10 Trench 10 .....	16
4.11 Finds.....	16
<b>5. PALAEOENVIRONMENTAL ASSESSMENT.....</b>	<b>17</b>
5.1 Introduction.....	17

5.2	Results.....	17
<b>6.</b>	<b>DISCUSSION .....</b>	<b>20</b>
6.1	Evaluation Trenches.....	20
6.2	Palaeoenvironmental Assessment.....	21
6.3	Potential .....	21
<b>7.</b>	<b>BIBLIOGRAPHY .....</b>	<b>23</b>
7.1	Cartographic Sources .....	23
7.2	Secondary Sources .....	23
<b>8.</b>	<b>ILLUSTRATIONS .....</b>	<b>25</b>
8.1	List of Figures .....	25
8.2	List of Plates .....	25
<b>APPENDIX 1: SPECIFICATION.....</b>		<b>26</b>
<b>APPENDIX 2: FINDS SUMMARY .....</b>		<b>27</b>
<b>APPENDIX 3: SUMMARY CONTEXT LIST.....</b>		<b>28</b>

## SUMMARY

---

Lakeside Partnership Ltd propose to undertake part of a residential development (Planning Reference 2202/1407) in the form of a spine road, associated roundabout and drainage, totalling 3.6ha within a 40ha site, at Brat Hill, between the A18 and the Bottesford Beck on the south-east side of Scunthorpe, North Lincolnshire (NGR SE 9165 0826). A desk-based assessment undertaken by John Samuels Archaeological Consultants (JSAC 2002) identified that the development site lies within an area of archaeological potential: many prehistoric stone tools have been recovered from the sandy warrens around Scunthorpe; and a series of late Iron-Age and Romano-British enclosures have recently been identified to the west of Lakeside (*ibid*). Accordingly, Oxford Archaeology North (OA North) were commissioned by JSAC, on behalf of Lakeside Partnership Ltd, to undertake a programme of archaeological evaluation within the 3.6ha development site.

The evaluation was undertaken in October 2005 and comprised the excavation of ten trial trenches to a maximum depth of 3.2m. Four of the trenches (Trenches 2-5), all located on the west side of the site, were positioned to examine the corridor of the proposed spine road drain, while Trench 1 was located adjacent to an existing balancing pond in order to investigate the proposed extension of this facility. A further five trenches (Trenches 6-10) were located in the area of the flood plain along the northern side of Bottesford Beck.

Trenches 7 and 8 were found to contain ditches likely to be of quite recent origin - one example in Trench 7 contained late nineteenth or twentieth century pottery. Each of the trenches revealed evidence of the blown sands that previous geotechnical studies had demonstrated covering much, if not all, of the site. Trenches 1 and 4 both revealed peat deposits sealed below this sand. The peat in Trench 1 (Layer **106**), along with the layers above and below it, were subjected to environmental sampling through the removal of a monolith core, whilst a bulk sample was also taken from the peat itself.

Subsamples of the monolith core from Trench 1 were assessed for the analytical potential of any preserved plant macrofossils, pollen and diatoms, while two samples, one from each of the top and the base of the peat sequence, were absolutely dated by radiocarbon assay. This indicated that the peat had been deposited in the Devensian II (Allerød Interstadial), between about 12,500 and 14,000 years ago. The palaeoenvironmental assessment suggested that the peat deposit was likely to have formed within a natural depression and, that fluctuations in conditions, potentially relating to the rapid climatic variation typical of the period, could be detected. Examples of archaeological and palaeoenvironmental material from this late glacial period, both nationally and regionally, are limited in number, and the site at Lakeside represents a rare opportunity to examine closely dated assemblages.

## ACKNOWLEDGEMENTS

---

Oxford Archaeology North would like to thank Karen Francis of John Samuels Archaeological Consultants (JSAC) for commissioning OA North to undertake the project and for her support. OA North would also like to thank Alison Williams of North Lincolnshire Archaeology Service for her advice and assistance during the fieldwork.

The evaluation was undertaken by Jeremy Bradley, Christina Clarke, Caroline Raynor, Alistair Vannan and Pascal Eloy. The report was written by Jeremy Bradley, with the drawings created by Marie Rowland and Mark Tidmarsh. The environmental samples were processed by Sandra Bonsall, while Elizabeth Huckerby assessed the plant remains. Diatoms were assessed by Dr Philip Barker and Dr Lydia King of the Department of Geography, Lancaster University. The finds were examined by Jo Dawson of Greenlane Archaeology Ltd. The project was managed by Stephen Rowland, who edited the report, together with Alan Lupton.

## 1. INTRODUCTION

---

### 1.1 CIRCUMSTANCES OF THE PROJECT

- 1.1.1 Lakeside Partnership Ltd proposes to undertake part of a residential development on land at Lakeside, Scunthorpe, North Lincolnshire (NGR SE 9165 0826; Planning Application No.2002/1407). The present development, covering 0.36ha, is situated within a wider 40ha site at Brat Hill (the majority of which has been heavily affected by mining - *Section 2.2.5*), between the A18 and the Bottesford Beck on the south-east side of Scunthorpe (Figs 1 & 2). The proposed development is to comprise a 420m long spine road with an associated roundabout and drainage services dug to depths of between 3m and 5m. A floodplain area, excavated to a depth of 0.85m and bounded by embankments, will be constructed between the A18 road and the Bottesford Beck within the eastern half of the development site. The existing circular balancing pond, towards the centre of the development site, will be greatly expanded westwards by *c* 127m and to a depth of *c* 4m, covering an area of 5200m<sup>2</sup>. North Lincolnshire Council granted full planning permission for the development, subject to the condition that a programme of archaeological field investigation be undertaken at the site.
- 1.1.2 Following completion of a desk-based assessment (JSAC 2002), John Samuels Archaeological Consultants submitted a specification for an archaeological evaluation of the western half of the spine road (*Appendix 1*), as this area was believed to have the best potential for preserved archaeological remains. The specification was approved by North Lincolnshire Archaeology Service and, JSAC, on behalf of the Lakeside Partnership Ltd, commissioned Oxford Archaeology North (OA North) to undertake the evaluation. The fieldwork, conducted between 3rd and 14th October 2005, comprised the excavation of ten trenches positioned to investigate areas of potential archaeological remains lying within the impact zone of the proposed development (Fig 3). Trench 1 was placed close to the current balancing pond towards the centre of the site, and was intended to investigate an area, to a maximum depth of 4m, that would be affected by the expansion of this feature. Trenches 2-5 were located within the western part of the site and were positioned to investigate the route of the proposed spine road and its associated services to a depth of 2m. Trenches 6-10, up to 1.2m deep, were placed within the eastern part of the site on the proposed floodplain area along the northern bank of the Bottesford Beck.
- 1.1.3 Following completion of the fieldwork, OA North were commissioned by JSAC to conduct a programme of radiocarbon dating and palaeoenvironmental assessment on a monolith sample taken during the evaluation. This work was carried out in December 2005 and January 2006 and involved the submission of two samples for absolute dating and the assessment of pollen, plant macrofossils and diatoms within subsamples from the monolith.

---

## 2. BACKGROUND

---

### 2.1 SITE LOCATION, TOPOGRAPHY AND GEOLOGY

- 2.1.1 The present development site, centred on NGR SE 9165 0826, is located at Brat Hill, between the A18 road and the Bottesford Beck on the south-eastern side of Scunthorpe, North Lincolnshire (Figs 1&2). The area of the proposed spine road lies at an average height of approximately 15m AOD and slopes down towards Bottesford Beck, which forms the southern boundary of the site. The western site boundary is formed by the existing residential development of Wisteria Way and by Brat Hill Farm caravan site. The Lakeside Retail Park and the edge of a large balancing pond define the eastern boundary. The A18 main road forms the northern boundary of the site.
- 2.1.2 The soils on the site are classed as ‘unsurveyed: urban and industrial areas’ (SSEW 1983). A ground investigation, comprising eight cable-percussion boreholes and 56 mechanically-excavated trial pits, was undertaken across the whole 40ha Lakeside development site by WSP Environmental Ltd in 2002 (WSP Environmental 2002) while a survey in 2003 focused on the proposed spine road area (WSP Environmental 2003). These investigations identified that, beneath c 0.2m of topsoil, up to 1.8m of made ground was present within the present development area. On occasion, areas of relict topsoil survived beneath the made ground, but more frequently this overlay extensive deposits of recent Blown Sand, locally with layers of soft peaty clays, itself overlying the Frodingham Ironstone of the Lower Lias of Jurassic Age at a depth of c 3.4m. The vegetation of the site is scrub, typical of derelict land, although exposed areas of sand are visible, as are the remnants of previous use, including areas of tarmac, re-worked sand, substantial drains and rubble (JSAC 2002). In addition, a concrete-lined pond is located in the south-west corner of the site.

### 2.2 ARCHAEOLOGICAL AND HISTORICAL BACKGROUND

- 2.2.1 *Prehistoric* the majority of prehistoric sites in the region of Scunthorpe comprise flint scatters. Those dating to the Mesolithic period are particularly common, especially around Risby and Crosby Warrens, to the north-east of the development site (Visitoruk.com 2005). Such finds of stone tools have almost exclusively been made within the wind-blown sand deposits around the town and which are likely to be the same as those identified on the development site by the geotechnical survey. Two prehistoric sites were identified by the JSAC (2002) desk-based assessment as lying within the development area: LS1960, a find-spot of Mesolithic and later flints (including scalene triangles, shouldered points and conical cores) at South Grange Farm (NGR SE 9126 0792); and LS4645, a find-spot of unspecified flints (NGR SE 913 078). Both were found in the 1930s during the construction of the sewerage plant at the western end of the current development area. Beaker period finds have been made at Ashby, where a beaker was recovered from a possible round barrow. Bronze Age finds are not represented within the current development area, but examples from



Scunthorpe's suburbs include food vessels from Crosby, bucket urns from the Beauchamp Mine, Brumby, a bronze hoard from Bagmoor and sheet bronze shields from nearby Brumby and Burringham (Visitoruk.com 2005). Several Late Iron Age and Romano-British enclosures have recently been identified to the west of Lakeside (JSAC 2002), while the Iron Age and Romano-British settlement at Dragonby lies about 7km to the north-east of the development site (Visitoruk.com 2005).

- 2.2.2 **Roman:** Romano-British sites are particularly prolific on the limestone edge to the west of Scunthorpe (North Lincolnshire Council 2003, 14.4). Again, the JSAC desk-based assessment identified several find-spots of Roman date located within the present development area during construction of the sewerage plant, including LS1866 and LS1897 comprising find-spots of Romano-British pottery at NGR SE 9153 0795 and SE 9142 0804 respectively. Bottesford, 2km to the west of the development area now a suburb of Scunthorpe, may have had its origins as a Romano-British village along the route of Ermine Street (North Lincolnshire Council 2005).
- 2.2.3 **Early Medieval:** although there is no contemporary evidence from the development site itself, Anglo-Saxon finds have been made in the surrounding areas, including a spear head and loom weight from Scunthorpe and pottery and a pair of missionary bells from Crosby Warren (Visitoruk.com 2005). The modern-day Lakeside site lies within the former territory of the early Anglo-Saxon kingdom of Lindsey, which eventually lost its independence in the seventh century to the expansion of the powerful kingdom of Northumbria. Of the five villages that coalesced to form modern Scunthorpe, only Frodingham (village of the descendants of Froda) bears a quintessentially early English name. That the general area consisted of rich farmland is demonstrated by the nearby site of Flixborough, which lies to the north-west. Anglo-Saxon Flixborough was a wealthy settlement and shows evidence of both secular and monastic phases; the site was occupied, if not necessarily continuously, from the late seventh to the fourteenth centuries (HAP/EH nd). Between the later ninth and tenth century, Lincolnshire fell within the Danelaw, the influence of which can be seen on the Scandinavian origin of Scunthorpe (meaning Skuma's Village - Treharne 2001) and of three other villages that form the modern city: Ashby, Brumby and Crosby.
- 2.2.4 **Medieval:** Scunthorpe appears in the Domesday Book as *Escumetorp*, as do others of the modern city's constituent villages, including Brumby (*Brunebi*), Bottesford (*Butlesford*), Crosby (*Cropesbi*) and Ashby (*Aschebi*), all of which (with the exception of Crosby) were held by the King, although not exclusively, under the manor of Kirton in Lindsey (Williams and Martin 1992). The records would suggest that much of the surrounding area was dominated by meadowland, with arable of perhaps secondary importance and very little in the way of woodland (*ibid*). Historically, the Lakeside site lies within the former township of Ashby, which, along with Burringham, Holme and Yaddlethorpe, formed part of the extensive parish of Bottesford. There was apparently a preceptory of the Knights Templar at Bottesford, for which Bottesford Manor House could possibly have been the gatehouse (North Lincolnshire Council 2005). Templars Bath, a spring in Manor Field, to the

west of the development area, was thought to have been used in connection with Templar ceremonies (*ibid*).

2.2.5 **Post-medieval:** up until the mid-nineteenth century, the development area and its surroundings would appear to have remained largely agrarian in character. However, a number of changes took place during the post-medieval period that are likely to have affected the development area. Among these were the concentration of landholdings and the intensification of agriculture, leading to rural depopulation and the encroachment of 'flying sands' which ruined large areas of previously productive agricultural land (Visitoruk.com 2005). Indeed, until the discovery of the Frodingham Ore fields in 1851, it is possible that the post-medieval settlement in and around the development area was much less intensive than during the Middle Ages. The steel industry was responsible for the expansion of the population of Scunthorpe and its surrounding areas from 1,245 in the 1850s to around 27,000 by 1919 (Towntalk 2005). Although Ashby was created as a separate civil parish in 1866 (JSAC 2002), the village, along with those of Brumby, Frodingham, Scunthorpe and Crosby, combined to form the modern town of Scunthorpe in 1936 (Towntalk 2005). By the 1970s, the population had risen to 60,000 people, a third of whom were employed in the steel industry (*ibid*). Early twentieth century opencast mining of the Frodingham Ore fields has seriously impacted, to a depth of up to 8m, upon much of the wider Lakeside development area. Of the 40ha site, only the 3.6ha of the present spine-road development has been left untouched by mining activity. However, even this limited area is not without disturbance, as the now-demolished 1930s sewerage plant, with its series of large tanks and filter beds within the western part of the site, demonstrates.

## 2.3 PREVIOUS ARCHAEOLOGICAL WORK

2.3.1 Aside from the JSAC desk-based assessment (2002), a watching brief was undertaken by Humber Field Archaeology in 1995, during the construction of the existing balancing pond. This recorded 2m of made ground within the area of the proposed balancing pond extension. Although the sewerage works had considerably truncated any deposits to the south of the balancing pond, 2m of seemingly natural stratigraphy survived to the north of the pond, including well-preserved organic deposits (JSAC 2002).

## 3. METHODOLOGY

---

### 3.1 WRITTEN SPECIFICATION

3.1.1 The NLAS-approved Specification compiled by JSAC (*Appendix 1*) was adhered to as far as possible throughout the evaluation, and all work was consistent with the relevant standards and procedures of the Institute of Field Archaeologists, and generally accepted best practice. Variations from the Specification were agreed with Karen Francis of JSAC and Alison Williams of NLAS and are detailed, where appropriate, in *Section 4*. These variations related largely to the fact that it was not always safe to enter trenches for the purposes of manual investigation due to the unstable nature of some of the trench sides, as a result of waterlogging and, particularly in the area of the demolished sewerage farm, contamination. The presence of buried concrete and of public paths also altered the size and shape of Trenches 5 and 10.

### 3.2 EVALUATION TRENCHING

- 3.2.1 The Specification required the excavation of ten trial trenches (Fig 3). Trenches 6-10, on the eastern side of the site, were each to be 2m wide, 50m long and 1.2m deep. Trenches 2-5, on the west side of the site were each to be 4m wide by 32m long. These trenches were excavated to a depth of 1m, before being stepped-in 1m on all sides and excavated to a total depth of 2m within the central portion of the trench. Trench 1 was located towards the centre of the site and measured 17m by 10.5m and had a maximum depth of 3.2m. To meet health and safety requirements, the sides of Trench 1 were battered at approximately 45 degrees to produce an internal area 4m wide by 8.5m long at the base of the trench (Fig 4).
- 3.2.2 Excavation of the uppermost levels of modern overburden/demolition material was undertaken by a mechanical excavator fitted with a toothless ditching bucket to the top of the first significant archaeological level. The work was supervised by a suitably experienced archaeologist. Spoil from the excavation was stored adjacent to each trench, and was backfilled upon completion of the archaeological works.
- 3.2.3 Where possible, archaeological deposits were cleaned manually to define their extent, nature, form and, where discernable, date. The two-dimensional positions of trenches and of archaeological features were established, where access allowed, by GPS survey techniques and height data was established using an optical level calibrated to Ordnance Datum.
- 3.2.4 All information identified in the course of the site works was recorded stratigraphically, using a system adapted from that used by the English Heritage Centre for Archaeology Service. Results of the evaluation were recorded on *pro-forma* context sheets, and were accompanied by sufficient pictorial record (plans, sections and both black and white and colour

photographs) to identify and illustrate individual features. Primary records were available for inspection at all times.

### 3.3 PALAEOENVIRONMENTAL ASSESSMENT

3.3.1 **Introduction:** during the evaluation of Trench 1, a thin lens of peat (**106**) was exposed. This had been sealed by overlying silt-laminated sands (**104** and **105**) and itself lay above the glacial till (**107** and **108**) (Plate 2). Following consultation with Alison Williams of NLAS and Karen Francis of JSAC it was decided to take samples of the peat material and of the layers above and below.

3.3.2 **Lithology:** in total, two sample cores, using three monolith tins, were taken from the exposed north-facing section within Trench 1 by an OA North Environmental Archaeologist. The removed monolith samples were wrapped in polythene and transported to OA North's offices in Lancaster. Core Sample 1 (two tins) was taken at between 11.87m OD and 10.87m OD, while Core Sample 2 (one tin) was taken at between 11.57m OD and 10.87m OD. Core Sample 1 was cleaned in the laboratory and the sediments were described and photographed. Sub-samples were taken for radiocarbon dating and for the assessment of pollen, plant macrofossils and diatoms.

3.3.3 **Pollen:** eight sub-samples were taken for pollen assessment from depths of 0.60m (11.27m OD), 0.61m (11.26m OD), 0.63m (11.24m OD), 0.64m (11.23m OD), 0.65m (11.22m OD), 0.66m (11.21m OD) and 0.70m (11.17m OD) from the top of the monolith. The eight samples were prepared for pollen analysis using the standard techniques of potassium hydroxide, hot hydrofluoric acid treatment, and acetolysis (Faegri and Iversen 1989). The residues were mounted in silicone oil and routinely examined at x400 magnification with an Olympus BH-2 microscope. Critical grains were examined using x1000 magnification. All eight sub-samples were assessed for pollen. To reduce the possible effects of differential dispersal under the coverslip, quantification continued until a sum of between 90 and more than 100 pollen grains from land pollen-types and ferns had been reached on two or more complete slides (after Brooks and Thomas 1967). Pollen identification was carried out using the standard keys of Faegri and Iversen (1989) and Moore *et al* (1991) and a small reference collection held at the OA North laboratory. Indeterminate grains were recorded using groups based on those of Birks (1973). Plant nomenclature followed Stace (1991). Charcoal particles greater than 500µm were also recorded, following the procedures of Peglar (1993). Data are presented in percentages (as a whole number except where less than 0.5%), with the exception of the pollen sum and charcoal sum, which are given in total grains.

3.3.4 **Plant macrofossils:** three sub-samples were taken from the monolith for the assessment of waterlogged and charred plant remains. The samples were taken at depths of 0.63m-0.65m (11.24m OD-11.24m OD), 0.67m-0.70m (11.22m OD-11.19m OD), and 0.76m-0.77m (11.11m OD-11.10m OD) from the top of Core Sample 1. The sub-samples were wet-sieved through 250µm mesh, and the residues retained in water. The flots were scanned with a Leitz/Wild

stereo-microscope and provisionally identified plant material was quantified as present or abundant. Botanical nomenclature followed Stace (1991).

- 3.3.5 **Radiocarbon dating:** two sub-samples of sediment from Core Sample 1 were submitted to Prof Dr Piert Grootes of the Leibniz Laboratory at Kiel, Germany, for their Express service AMS measurement. The samples were taken at depths of 0.65m-0.66m (11.22m OD-11.21m OD) and 0.605m-0.615m (11.245m OD-11.235m OD) from the top of the core.
- 3.3.6 **Diatoms:** four sub-samples, taken at depths of 0.60m (11.27m OD), 0.62m (11.25m OD), 0.63m (11.24m OD) and 0.69m (11.18m OD) were submitted to Dr Philip Barker and Dr Lydia King of the Geography Department of the University of Lancaster, who prepared the samples using their standard procedures.

### 3.4 ARCHIVE

- 3.4.1 The results of the fieldwork will form the basis of a full archive to professional standards, in accordance with current English Heritage (1991) and UKIC (1990) guidelines. The project archive represents the collation and indexing of all the data and material gathered during the course of the project. The deposition of a properly ordered and indexed project archive in an appropriate repository is considered an essential and integral element of all archaeological projects by the IFA in that organisation's code of conduct.
- 3.4.2 The archive for the archaeological work undertaken at the site will be deposited with the nearest museum which meets Museums and Galleries Commission criteria for the long-term storage of archaeological material (MGC 1992). This archive can be provided in the English Heritage Centre for Archaeology format, both as a printed document and on computer disks as ASCII files (as appropriate). The archive will be deposited with the nominated museum within six months of the completion of the fieldwork. Except for items subject to the Treasure Act, all artefacts found during the course of the project will be donated to the receiving museum.
- 3.4.3 A synthesis (in the form of the index to the archive and a copy of the publication report) will be deposited with the North Lincolnshire Sites and Monuments Record. A copy of the index to the archive will also be available for deposition in the National Archaeological Record in London.

## 4. RESULTS

---

### 4.1 TRENCH 1

- 4.1.1 Trench 1 was located in the centre of the site immediately west of the balancing pond and was positioned to examine the peat deposits recognised during geotechnical investigations of the site (WSP 2003). The current ground level was *c* 14.8m OD. Trench 1 was aligned east/west and measured 17m by 10.5m with a maximum depth of 2.8m, at which point peat deposits were reached (*c* 12m OD). The sides of the trench were battered at approximately 45 degrees to produce an internal area 4m wide by 8.5m long at the base of the trench (Fig 4; Plate 1). A 3.5m by 2.5m sondage was excavated to a total depth of 3.35m below current ground surface at the east end of the trench, partially to act as a sump for the inflowing groundwater and partially to ascertain the depth of the peat deposit which otherwise formed the base of the trench.
- 4.1.2 The lowest deposit, encountered within the northern part of the very base of the sondage, was composed of blue/grey, very compact gravel, **109** (Plate 2). Overlying this was a silty gravel, **108**, which sloped down to the south, and was blue/grey in colour at the base and golden-yellow at the top. Above this, was a layer of blue/grey silt, **107**, which dipped to the east and which in turn was sealed by peat **106**. Peat layer **106** was 0.28m thick and extended over the entire base of the trench, at a depth of 2.8m from the present ground surface (Fig 5). This dark brown, almost black, humified peat contained wood fragments, and was sealed by **105**.
- 4.1.3 Layer **105** was 0.50m thick, comprised orange-yellow to greyish-yellow sharp sands laminated with thin undulating bands of fine grey silt and represented the lower of two substantial layers of sand. Layer **105** was fluvial in origin and was presumably laid down during a period when this part of the site formed the Bottesford Beck flood plain. These lower sands (**105**) in turn, were sealed by 0.78m thick layer of pale yellow to greyish-yellow fine sand, **104**, which was mostly free of the laminations present in the lower material. The lack of laminations might indicate that the sand layer **104** was aeolian in origin. Deposit **105** and **106** were further examined by Core Samples 1 and 2, with further material from **106** collected as a bulk sample (Fig 5).
- 4.1.4 The area above sand layers **104** and **105** had previously been levelled and sealed below a 0.91m deep deposit of dark grey slag, **103**. This in turn had been sealed by a 0.25m thick layer of brownish-yellow silty clay, **102**, which itself had been overlain by 0.1m thick grey clay, **101**. The uppermost deposit, 0.1m in depth, was composed of brownish-grey topsoil, **100**.

### 4.2 TRENCH 2

- 4.2.1 Trench 2 was located at the west end of the site, north of an existing balancing pond and positioned to examine the corridor of the spine road drainage system. The trench was aligned north-west/south-east and measured 32m long by 4m

wide. The trench was excavated to a depth of 1m, before being stepped-in 1m on all sides and excavated to a total depth of 2m within the central portion of the trench. The present ground level lay at c 16.2m OD.

- 4.2.2 The basal stratigraphic unit comprised a 0.60m thick layer of orange-brown, sandy silt clay, **205**. This was then sealed by a 0.35m thick layer of yellow/white sand, **204**. Sealing this, at a depth of 0.9m below current ground level (c 15.30m OD) was a 0.15m thick layer of brownish-yellow/grey sandy silt, **203**, which contained dark clasts of redeposited peat. This material was likely to have been relict topsoil buried under the made ground layers.
- 4.2.3 Overlying relict topsoil **203** in the south-east end of the trench and visible extending for a distance of 10m, was a 0.15m thick layer of tarmac, **201**. The tarmac, along with deposit **203**, was then sealed by brownish-orange, sandy gravelly silt, **202**, which was 0.60m deep, but shallower above the tarmac. The topsoil, **200**, was 0.30m thick and was composed of loose, orange-brown sandy silt. No archaeological deposits or features were seen.

### 4.3 TRENCH 3

- 4.3.1 Trench 3 was located approximately 150m east of Trench 2 and was aligned north/south. It too was positioned to examine the corridor of the spine road drainage system. The trench measured 30m long by 4m wide and was excavated to a depth of 1m, before being stepped-in 1m on all sides and excavated to a total depth of 2m within the central portion of the trench. The present ground level lay at c 15m OD.
- 4.3.2 Natural yellow sand, **303**, was seen sporadically in the base of the trench at a depth of 2.20m (c 12.8m OD). Sealing this, was a 1m thick layer of brownish-yellow sand, **302**, which contained occasional brick rubble. This was then overlain by a layer of up to 0.60m of slag, **301**. A layer up to 0.40m in depth comprised the mid-brown, silty sand topsoil, **300**.

### 4.4 TRENCH 4

- 4.4.1 Trench 4 was located approximately 40m north-east of Trench 3, was aligned east/west and was also positioned to examine the corridor of the spine road drainage system. The trench measured 32m long by 4m wide and was excavated to a depth of 1m, before being stepped-in 1m on all sides and excavated to a total depth of 2m within the central portion of the trench. The present ground level lay at c 14.70m OD. This trench was considered to be located in the most contaminated area of the site and it was thus not possible to enter the trench and manually investigate deposits.
- 4.4.2 A 0.12m thickness of blue/grey fine sandy silt, **405**, was seen in the base of the trench (Fig 6). Lying above this was a 0.10m thick layer of very dark brown humified peat, **404**. A 0.60m thick layer of pale yellow to orange laminated sands, **403**, then sealed the peat. The laminations within sands **403** were composed of grey/brown silt. Above this was what was presumed to be a relict

topsoil, **402**, which was 0.15m thick and composed of brown silty sand. This layer had then been sealed below 0.20m of brown sand, **401**, which had then been sealed by a 0.83m thick levelling layer of stiff grey clay, **400**. Layer **400** contained approximately 5% limestone fragments that measured between 70mm and 150mm. Although this layer was grassed over, there was no evidence of topsoil.

## **4.5 TRENCH 5**

4.5.1 Trench 5 was located 50m to the south of Trench 1 and was once again located to investigate the spine road drainage corridor. The trench was aligned east/west and measured only 6m long by 4m wide. This was due to the presence of reinforced concrete and concrete rubble and re-bars within the upper layer of the trench, which made excavation almost impossible. It was agreed with the North Lincolnshire County Archaeologist, Alison Williams, and the JSAC consultant, Karen Francis, that a much reduced trench length would suffice. The trench was, however, excavated in a similar manner to Trenches 2-4, being stepped in to a depth of 2m. The present ground level lay at c 15.0m OD.

4.5.2 The lowest deposit comprised a 0.60m thick deposit of yellow-white sand with iron staining, **504** (Plate 3). This was capped by an irregular layer of dark brown organic peat, **503**, up to 0.60m. This was then sealed by a layer of orangey brown sand, **502**, 0.56m thick. A layer of slag, **501**, and brown silt had then been placed on top of **502** to a depth of 1m. This in turn had been sealed by a layer of compact brown clay, **500**, which also contained the top soil.

## **4.6 TRENCH 6**

4.6.1 Trench 6, along with Trenches 7-10, was positioned in the flood plain area to the east of Trench 1. The west-north-west/east-south-east aligned trench was 50m long by 2m wide and 1.20m deep and was located close to Bottesford Beck. The present ground level lay at c 13.0m OD.

4.6.2 The excavation of Trench 6 proved to be very problematic. Soon after the trench was opened, the trench sides collapsed while the swift ingress of water flooded the base of the trench to a depth of approximately 0.40m, further hampering recording. Although a possible ditch was seen during machining, it soon succumbed to the rising waters. An attempt to re-locate the feature proved futile, with the level of dirty water in the trench proving to be too much of an obstacle. Although the utilisation of a pump was considered, the proximity of the trench to the Bottesford Beck meant that such measures would have had little positive effect. In the event, only the upper half of the trench stratigraphy could be recorded with any confidence. This comprised 0.40m of dark brown/black peaty topsoil, **600**, that sealed a layer of pale yellow-brown fine sand, **601**. Any deposits below about 1m were not visible.



#### 4.7 TRENCH 7

- 4.7.1 Trench 7 was located quite close to, and to the north-east of, Trench 6 on a roughly north-east/south-west orientation. Trench 7 measured 50m long by 2m wide and 1.20m deep. Like Trench 6, Trench 7 was subject to flooding and collapse, most notably at the south-west end, where flooding extended to at least half of the trench. The present ground level lay at *c* 13.4m OD at the north-east end of the trench, dropping to 12.8m at the south-west end.
- 4.7.2 The basal layer within the trench comprised a 0.70m thickness of pale sand, **701**, with notable lenses/laminations of peat toward the south-west. This was capped by a layer of peat, **708**, 0.10m thick. This deposit was then sealed below a further layer of orange sand, **707**, 0.25m thick (Figs 7 & 8). The trench was sealed by a 0.10m thick layer of topsoil, **700**.
- 4.7.3 Located half way along the trench was a substantial ditch, **705**, that cut layer **708**. Ditch **705** was 5m wide, 0.70m deep and aligned north-north-west/south-south-east. The fill, which appeared to represent natural silting, was composed of almost desiccated, humified peat, **704**. The fill was examined for artefacts but none were recovered. Once the ditch had silted-up, the area had been levelled by spreading a 0.20m – 0.30m thick layer of orange-brown “dirty” sand, **706**, within the slight depression left above the ditch. Deposit **706** contained the occasional plastic bag, indicating that the levelling was a fairly recent event.
- 4.7.4 It would appear likely that another substantial ditch, **703**, was aligned almost at right angles to **705** and probably formed part of the same field boundary system, although there was no direct physical relationship between these two features within the confines of the trench. Ditch **703** was approximately 3.5m wide at the base and may have been upwards of 7m wide at the surface; however, its angle and position in the trench made it difficult to ascertain its true dimensions. Ditch **703** was filled with peat **702**, which contained late nineteenth and/or twentieth century pottery.

#### 4.8 TRENCH 8

- 4.8.1 Trench 8 was located to the east of Trench 7 and was aligned north-west/south-east. It measured 50m long by 2m wide and 1.20m deep. The present ground level lay at *c* 13.30m OD. A layer of clean orange sand, **801**, was recorded as the basal layer in the south-eastern half of the trench. Overlying this, and sloping up to the north-west, was a layer of white sand, with lenses of peat, **810**. Three ditches were recorded within the trench, all of which were cut into sand layer **810**.
- 4.8.2 At the north-western end of the trench a north/south orientated ditch, **803**, had a single fill, **802**, and was sealed by topsoil **800** (Plate 4). Ditch **803** must have been quite substantial, as it was excavated a further 0.70m below the base of the trench in that area and was not bottomed at that depth due to the ingress of water. Some 9m from the north-west end of the trench were two intercutting ditches, **805** and **809**. The earliest ditch, **809**, was 1.20m deep, over 1.75m

wide and aligned north/south. Ditch **809** contained three fills, the earliest of which was composed of mid-greyish-brown clean silty sand, **808**. This was sealed by bands of orange, yellow and light brown sand, **807**. The upper fill was composed of peat, **806**. There was evidence of animal disturbance on the western side of the ditch. Cutting into ditch **809**, and visible only in section, was an east/west aligned ditch, **805**. This ditch was 2m wide and over 1.20m deep. The fill, **804**, was composed of mottled sand with peat lenses. Both features are thought to be fairly recent in date as they were cut into the top of the sand and sealed below the mid- to light brown silty sand topsoil, **800**.

#### **4.9 TRENCH 9**

4.9.1 Trench 9 was located approximately 30m east of Trench 8 and aligned east/west. It was 50m long by 2m wide and 1.20m deep. The present ground level lay at c 13.30m OD. The lowest stratigraphic unit comprised white sand, **903**, which was 0.60m thick and contained occasional lenses of clay or silt (Plate 5). This was sealed by an interface layer, **902**, composed of black sand, the dark colouration of which may be derived from the 0.10m thick peat layer, **901**, above. Peat **901** was then sealed by a layer of mid-brown silty sand topsoil, **900**.

#### **4.10 TRENCH 10**

4.10.1 Trench 10 was located east of Trench 9 and, due to the presence of a footpath and scrub, the shape of the trench was altered to an 'L' shape. The east/west axis of the trench measured 22m, while the north/south axis measured 20m. The present ground level lay at c 13.6m. The basal fill of the trench was composed of a 0.75m thick layer of white sand, **1003**, which contained peat and clay lenses. Sealing this was a 0.15m thick layer of reddish-brown friable peat, **1002**. A further layer of clean yellow sand, **1001**, sealed the peat, while the sand was capped by mid-yellowish-brown silty sand topsoil, **1000**.

4.10.2 A single feature, **1004**, was located at the north end of the trench within sand layer **1003** (Plate 6). Feature **1004** was circular, 0.95m in diameter and 0.14m deep. The fill, **1005**, was composed of concentric layers of sand and peat. A sample was taken of deposit **1005**, although feature **1004** is thought to be natural.

#### **4.11 FINDS**

4.11.1 The finds retrieved from the deposits have been catalogued in *Appendix 2*, and this includes footnotes explaining all of the more precise dates listed. The primary aim in retrieving the finds was determining these dates, and the information in *Appendix 2* has been used to date ditch fill **704**, from which all the finds were recovered, to the late nineteenth to early twentieth century. All appeared to represent domestic refuse, and were not particularly abraded, perhaps indicating opportunistic dumping.

## 5. PALAEOENVIRONMENTAL ASSESSMENT

### 5.1 INTRODUCTION

5.1.1 During the evaluation of Trench 1, a thin lens of peat (**106**) was exposed. This had been sealed by overlying silt-laminated sands (**104** and **105**) and itself lay above the glacial till (**107** and **108**) (Plate 2). Sands **104** and **105** were thought to have been laid down in either the early Holocene, or as a result of redeposited sediment arising from increased clearance in the Romano-British period.

### 5.2 RESULTS

5.2.1 **Lithology:** a complex lithological sequence was recorded within Core Sample 1, and is summarised in Table 1. The individual silt bands were not examined during this phase of the study and the following interpretation is tentative. It is thought that they may have been laid down under low energy conditions, either within a fluvial or lacustrine environment (Denise Druce *pers comm*).

Depth (m)	Description
0-0.02	Sand
0.02-0.03	Silt band with organic remains
0.03-0.04	Sand
0.04-0.05	Silt band with organic remains
0.05-0.06	Sand
0.06-0.08	Silt band with organic remains
0.08-0.09	Sand
0.09-0.10	Silt band with organic remains
0.10-0.32	Silt band with organic remains
0.34-0.37	Sand
0.37-0.39	Silt band with organic remains
0.39-0.51	Sand
0.51-0.52	Silt band with organic remains
0.52-0.55	Orange sandy banding
0.55-0.58	Banded layer with brown-grey clayey sand
0.58-0.60	Grey organic clay
0.60-0.62	Dry humified peat
0.62-0.64	Grey silty band
0.64-0.67	Dry humified peat
0.67-0.71	Dark grey silty clay
0.71-0.80	Clay with sandy inclusions and peat banding: could be ancient root channel
0.80+	Glacial till

Table 1: Description of Core Sample 1. Depths are in metres from top of the core, which lay at 11.87m OD.

5.2.2 **Radiocarbon dating:** the results of the radiocarbon dating are shown in Table 2. The dates have placed the peat band firmly within the Late Devensian II (the Allerød Interstadial), a period of temporary climatic amelioration precipitating the retreat of the last glaciation.

Depth (m)	Laboratory code	Radiocarbon age	Calibrated date
0.605-0.615	KIA28602	10740±70BP	11045-10450cal BC
0.65-0.66	KIA28603	11230±40BP	11804-11055 cal BC

Table 2: Results of radiocarbon dating from Lakeside, Scunthorpe. The dates have been calibrated using the CALIB rev 4.3 (Data set 2) (Stuiver *et al* 1998)

Depth (m) from top of Core Sample 1	0.60	0.61	0.62	0.63	0.64	0.65	0.66	0.70
Total Trees + Shrubs	19	15	10	7	10	9	13	42
Total Herbs	78	82	88	93	89	87	80	55
Total ferns	3	3	2		1	4	7	3
<b>Trees and shrubs</b>								
<i>Betula</i> - birch	9	9	9	6	7.4	4.4	9.2	38.1
<i>Pinus</i> - pine	5.5	4	1	1.3	2.2	2.2	1.3	0.9
<i>Salix</i> - willow	4.5	3			0.7	2.9	2.6	2.7
<b>Herbs</b>								
Poaceae - grasses	25.7	80	60	82	49.2	71.5	34.8	18.2
Cyperaceae - sedges	40	2	13	6	23.1	7.3	40.8	15.5
<i>Plantago lanceolata</i> - ribwort plantain	0.9							
<i>Plantago</i> sp - plantains		3						
<i>Rumex</i> - dock/sorrel						0.7		0.9
<i>Filipendula</i> - meadowsweet			1	0.7	2.2	1.4	1.3	0.9
<i>Artemisia</i> - mugwort	0.9							1.8
<i>Urtica</i> - nettle					1.5	0.7		
Caryophyllaceae - stitchwort family	2.8				1.5			2.7
<i>Lotus pedunculatus</i> - greater bird's-foot-trefoil							0.6	
Lamiaceae - deadnettle family	0.9							
Apiaceae - carrot family					0.7	0.7		
Rosaceae - rose family					15			
<i>Potentilla</i> - cinquefoils					1.5			
Rubiaceae - bedstraw family						0.7		
<i>Ranunculus</i> sp - buttercups			1	1.3	1.5	0.7		1.8
<i>Thalictrum</i> - meadow-rue	0.9							
<i>Melampyrum</i> - cowwheat				0.7				
<i>Cf Menyanthes trifoliata</i> - bogbean		2	1					
<i>Armeria maritima</i> - thrift							0.6	
<i>Saxifraga</i> sp - saxifrage								0.9
Undifferentiated herbs	4.5	5	2	1.3	3.7	5.8	0.6	0.5
<b>Aquatics</b>								
<i>Potamogeton</i> - pondweed	2.8							
<i>Myriophyllum spicatum</i> - spiked water-milfoil	0.9							
<i>Myriophyllum alterniflorum</i> - alternate water-milfoil			1					
<i>Typha angustifolia</i> - lesser bulrush						0.7		1.8
<i>Callitriche</i> - water-starwort							0.6	
<i>Sphagnum</i> - sphagnum moss							1.3	
Isoetes - quillwort							0.6	
Botryococcus	4.5			1.3		0.7		2.7
Pediastrum	68.9			3.4	0.7	0.7		82.9
<b>Ferns</b>								
Pteridopsida (monolete) - monolete ferns	2.8	3	2		3.4	3.6	6.6	2.7
<i>Botrychium</i> - moonwort							0.6	
<i>Equisetum</i> - horsetail	1.8							
<b>Indeterminate grains</b>	22.9	7	6	8.6	11.9	8.8	6.6	11.8
<b>Pollen sum (total)</b>	<b>109</b>	<b>100</b>	<b>100</b>	<b>150</b>	<b>134</b>	<b>137</b>	<b>152</b>	<b>110</b>

Table 3: Percentage pollen data from Lakeside, Scunthorpe. Pollen sum includes all terrestrial pollen and fern spores.

- 5.2.3 **Pollen:** the eight sub-samples all contained abundant well-preserved pollen. At a depth of 0.70m, tree and shrub the pollen were more frequent, with birch (*Betula*) the major type, with lesser amounts of pine (*Pinus*) and willow (*Salix*). These taxa continued to be recorded in all the samples but, further up the core, grass (Poaceae) and sedge (Cyperaceae) pollen become more important, together with the pollen from other herbaceous plants, such as meadowsweet (*Filipendula*) and buttercups (*Ranunculus*). There are fluctuations in the relative numbers of pollen grains from sedges and grasses between samples, but the local environment would have continued to be that of an open herbaceous community with some birch and willow scrub.
- 5.2.4 **Plant macrofossils:** waterlogged plant and insect remains were recorded in each of the three assessed sub-samples (Table 4). The lower sample contained abundant fine detritus with some wood fragments. Very high numbers of sedge (*Carex*) seeds together with seeds of crowfoot (*Ranunculus* Batrachium-type), pondweed (*Potamogeton*) and gipsywort (*Lycopus europaeus*) were recorded in the sample from a depth of 0.67-0.70m. Towards the top of the peat, plant remains became less frequent, but the presence of a number of fragments of bogbean (*Menyanthes trifoliata*) seeds suggests that the environment was becoming more acidic.

Depth (m)	Matrix	Plant remains	Insect	minerogenic
0.63-0.665	Amorphous plant material+	Fragments of <i>Menyanthes</i> seeds and cf <i>Hydrocotyl</i> <i>Chara?Nitella oospores</i>	+	Sand
0.67-0.70	Wood ++, Amorphous plant material ++	Seeds <i>Carex</i> , <i>Lycopus europaeus</i> , <i>Potamogeton</i> , and <i>Ranunculus</i> Batrachium	+	+
0.76-0.77	Amorphous plant material (fine) ++, monocote stems, wood frags	Single <i>Carex</i> seed	+	++

Table 4: Assessment of waterlogged plant remains. Sub-samples in depth in metres from top of core sample 1. + is present and ++ is very abundant

- 5.2.5 **Diatoms:** no diatoms were preserved within the four sub-samples assessed. The mineral fraction within each sample comprised fine silt, with no suggestion of dissolution of the silica that could indicate that diatoms were once present. The only environmental information that can be given, based on the absence of diatoms, is that the deposit was not formed under water in a pond or stream. Neither were there lots of phytoliths (silica remains of grasses) suggesting true soils. The silty/clayey bands immediately above and below the main peat lens (0.6-0.67m), were thought to derive from colluvium, while the absence of diatoms would suggest limited standing water.

## 6. DISCUSSION

---

### 6.1 EVALUATION TRENCHES

- 6.1.1 Overall, there was very limited evidence for archaeological features on the site, with those that were identified, for example the ditches found within Trenches 7 and 8, being of late post-medieval date. Although both prehistoric and Roman chance finds have been found within the evaluated area, notably from the western part of the site formerly occupied by the sewerage plant, there was no indication that any of the identified features dated from these periods, and there were no further chance finds of contemporary artefacts.
- 6.1.2 There was evidence within the western part of the site, particularly from Trenches 2, 3 (where made ground deposits reached 2m in thickness) and 5, that activity relating to the construction, use and demolition of the sewerage farm had truncated deposits seen within the evaluation trenches. While the full extent of this truncation cannot be accurately ascertained, it is possible that any post-glacial archaeological deposits within the areas investigated by the evaluation trenches have been completely destroyed.
- 6.1.3 The less-disturbed eastern part of the site was completely different in character to that of the west. All five trenches showed a similar sequence of deposits, with sands - sometimes laminated - overlain by localised layers of peat and/or topsoil. In Trench 7, the two substantial ditches, **703** and **705**, appeared to form part of a field boundary, dated on the basis of pottery to the late nineteenth or twentieth century. The same is likely to be true of the undated intercutting ditches located within Trench 8. In both trenches, the ditches were cut from immediately below the topsoil and so are thought to be of similarly late post-medieval origin. Considering the degree of sediment deposition in this area, which is likely to relate to flooding of the Bottesford Beck, it is possible that any earlier archaeological features are masked by alluvial deposits and lie at a depth greater than the 1.2m investigated by the evaluation in this area, below the maximum depth of development impact.
- 6.1.4 That these fluvial deposits extend into the more westerly parts of the site is demonstrated by the stratigraphy within Trench 1. In particular, the lower band of sand identified within Trench 1, **105**, was fluvial in origin. Furthermore, by analogy, those sand deposits that were seen locally to contain peat and thin silty laminations - in particular those in Trench 4, contexts **404** and **405** - are also likely to be fluvial rather than aeolian in origin. This demonstrates that not all the sand located within the trenches was wind-blown in origin as had been suggested by the earlier geotechnical surveys. Although the overall area investigated by Trench 1 was very small, it does show an absence of archaeological activity between the Devensian peats and the alluvial deposits. Across the development area as a whole, it is possible that the generally low-lying area, susceptible to seasonal flooding and peat accumulation, was grazed and, in earlier prehistory, used for hunting, but perhaps not human habitation.

## 6.2 PALAEOENVIRONMENTAL ASSESSMENT

- 6.2.1 The results of the radiocarbon dating would suggest that peat layer **106** within Trench 1 could have accumulated over a long period during the Devensian II (the Allerød Interstadial) some 12,500 - 14,000 years ago. As the ice retreated after the last glaciation, the climate ameliorated (Devensian II) before becoming colder again (Devensian III), finally warming-up about 10,000 years ago in the Holocene (the present interglacial period). The peat deposits at Lakeside were formed in a damp hollow left as the ice started to retreat in the warmer Devensian II. As the climate cooled in the Devensian III, the peat deposits would appear to have been covered by sand, which may have blown over the area or have been water-lain under low energy conditions.
- 6.2.2 The results of the pollen assessment demonstrate that the development site would have hosted a typical Late Devensian open herbaceous community, with some scrubby birch (*Betula*) and willow trees (*Salix*), as would be seen today, for example, in the Jotunheim Mountains of Norway. The plant macrofossils suggest that when the peat was accumulating, the ground was either damp or a shallow body of water. At the time when the base of the main peat lens was accumulating, the site would have been covered by a dense mat of sedges with some gypsywort (*Lycopus europaeus*) and pondweed (*Potamogeton*) within standing water. These initial wetter conditions are also indicated by the identification of the two microscopic colonial algae *Pediastrum* and *Botryococcus* within the lower samples. In time, the site would appear to have become drier before becoming wetter again towards the top of the lens. The seeds of bogbean (*Menyanthes trifoliata*) suggest that conditions became more acidic during the periods when the upper parts of the peat lens were accumulating, perhaps enhancing the survival of the peat after 11045-10450cal BC (10740±70BP; KIA28602).
- 6.2.3 Late Devensian sites are rare in Lincolnshire and Yorkshire. Two examples comprise that at the Bog at Roos in Holderness, East Yorkshire (Beckett 1981 cited in Van der Noort and Ellis, 1995), and the site at Abbey Grange on the western edge of Middle Marsh, Lincolnshire (Suggate and West, 1959 cited in Ellis *et al* 2001). Because there are so few examples, the present site is very important palaeoecologically. A shallow water body with a rich herbaceous vegetation, as indicated by the assessment of peat **106**, would have provided both grazing and water for the large herbivores that roamed the landscape as the ice retreated. At Poulton-le-Fylde, Lancashire, the remains of an elk, "Horace," with scars suggesting that it had been hunted, were found in the 1970s in a Late Devensian II deposit (Middleton *et al* 1995). Palaeoecological research of such deposits will help our understanding of how the climate has dramatically changed in the past, with resulting implications for our understanding of the present global warming.

## 6.3 POTENTIAL

- 6.3.1 Further groundworks on the site would provide a unique opportunity to examine the Later Palaeolithic landscape. If large mammals were using the shallow water body for drinking and the surrounding vegetation for grazing

during the more clement conditions of the Allerød Interstadial, there is a possibility that human artefacts may be recorded. This site has a very high potential for recording the environmental conditions in the Late Palaeolithic as well-preserved pollen, plant macrofossils and insect remains were all present within the sub-samples assessed from the site.

- 6.3.2 The assessment has indicated that the palynological and plant macrofossil remains from the existing monolith samples have a high potential for full analysis. The study of insect remains in Late Devensian sequences is extremely informative, as migratory insects respond more rapidly to temperature changes than plants. The potential for any analysis of the insect remains would need to follow a full entomological assessment by an appropriate specialist, for which additional, larger, samples might be recommended. To add to our understanding of the development of the depositional sequence at the site, the existing samples would benefit from analysis by a sedimentologist, who might also wish to make a site visit during further groundworks.



## 7. BIBLIOGRAPHY

---

### 7.1 CARTOGRAPHIC SOURCES

British Geological Survey 1: 50,000 scale geological map, Sheet

Soil Survey of England and Wales, 1983 1:250,000 Sheet 4

### 7.2 SECONDARY SOURCES

Blakeman, A, 2002 *Miller's Bottles and Pot Lids: A Collector's Guide*, London

Beckett, SC, 1981, Pollen diagrams from Holderness, North Humberside, *Journ of Biogeog*, **8**, 177-98

Birks, HJB, 1973 *Past and present vegetation of the Isle of Skye: A palaeoecological study*, Cambridge

Brooks, D, and Thomas, KW, 1967, The distribution of pollen grains on microscope slides. 1. The non randomness of the distribution, *Pollen and Spores*, **9**, 621-9

Ellis, S, Fenwick, H, Lillie, M, and Van de Noort, R, 2001, *Wetland Heritage of the Lincolnshire Marshes*, Humber Wetlands Project, Hull

English Heritage, 1991 *The Management of Archaeological Projects*, Second edition

Faegri, K, and Iversen, J, 1989 *Textbook of modern pollen analysis*, Fourth edition (Rev K Faegri, PE Kaaland, and K, Krzywinski), Chichester

Fletcher, E, 1972 *Bottle Collecting: Finding, Collecting and Displaying Antique Bottles*, London

HAP/EH, nd <http://www.hullcc.gov.uk/archaeology/flixboro.htm>

HP Foods, n.d. *Brands: HP Sauce: History*, <http://www.hpfoods.com/brands/hpsauce/>

JSAC, 2002 *An Archaeological Desk-based Assessment of Lakeside, Scunthorpe, North Lincolnshire*, Unpubl rep 971/02/01

Middleton, R, Wells, CE and Huckerby, E, 1995 *The Wetlands of North Lancashire*, Lancaster Imprints 4, Lancaster.

Moore, PD, Webb, JA, and Collinson, ME, 1991 *Pollen analysis*, Second edition, Oxford

Museum and Galleries Commission, 1992 *Standards in the Museum care of Archaeological Collections*

North Lincolnshire Council, 2003 *Scunthorpe Region and District Local Plan*

North Lincolnshire Council, 2005 *Bottesford Local History Pack*  
<http://www.northlincs.gov.uk/NorthLincs/Leisure/libraries/localandfamilyhistory/localstudies/localhistorypacks/Bottesford.htm>

Peglar, SM, 1993 The mid Holocene *Ulmus* decline at Diss Mere, Norfolk, UK: a year-by-year pollen stratigraphy from annual laminations, *Holocene*, **3(1)**, 1-13

Stace, C, 1991, *New Flora of the British Isles*, Cambridge

Stuiver M., P.J. Reimer, E. Bard, J.W. Beck, G.S. Burr, K.A. Hughen, B. Kromer, G. McCormac, J. van der Plicht and M. Spurk 1998 INTCAL98 Radiocarbon Age Calibration, 24000-0 cal BP *Radiocarbon* **40(3)** 1041-1083

Suggate, RP and West RG, 1959 The extent of the late Glaciation of East Anglia, Proc of the Roy Soc of London, 150, 263-83

Towntalk, 2005 *Scunthorpe's History*, [www.scunthorpe.towntalk.co.uk/history.php](http://www.scunthorpe.towntalk.co.uk/history.php)

Treharne, E, 2001 *Legacy of the Vikings*  
[www.bbc.co.uk/history/lj/conquestlj/legacy\\_02](http://www.bbc.co.uk/history/lj/conquestlj/legacy_02)

UKIC, 1990 *Guidelines for the Preparation of Excavation Archives for Long Term Storage*

Van der Noort, R and Ellis, S, 1995 *Wetland Heritage of Holderness*, Humber Wetlands Project, Hull

Visitoruk.com, 2005 *Timeline History of Scunthorpe*,  
[www.scunthorpeuk.com/index.cfm](http://www.scunthorpeuk.com/index.cfm)

Williams, A, and Martin, G,H, 1992 *Domesday Book - A Complete Translation*  
Penguin

WSP Environmental Ltd, 2002 *Phase I and II Ground Investigation Report: Lakeside, Scunthorpe*. Unpubl rep

WSP Environmental Ltd, 2003 *Supplementary Ground Investigation Report: Lakeside, Scunthorpe*. Unpubl rep

## 8. ILLUSTRATIONS

---

### 8.1 LIST OF FIGURES

Figure 1: Location Map

Figure 2: Evaluation Location Map

Figure 3: Trench location plan

Figure 4: Plan of Trench 1

Figure 5: North-facing sample section through Trench 1, inset shows deposits examined by monolith cores 1 and 2.

Figure 6: South-facing sample section through Trench 4

Figure 7: North-north-west-facing section through Ditch 705, Trench 7

Figure 8: Plan of Trench 7

### 8.2 LIST OF PLATES

Plate 1: General View of Trench 1 following recording and preparation of section for monolith sampling

Plate 2: North-facing section in Trench 1 prior to taking of monolith samples

Plate 3: Trench 5, facing east

Plate 4: Oblique view of ditch **803** in north-facing section of Trench 8

Plate 5: North-west-facing section within Trench 9

Plate 6: Half section through circular feature in Trench 10

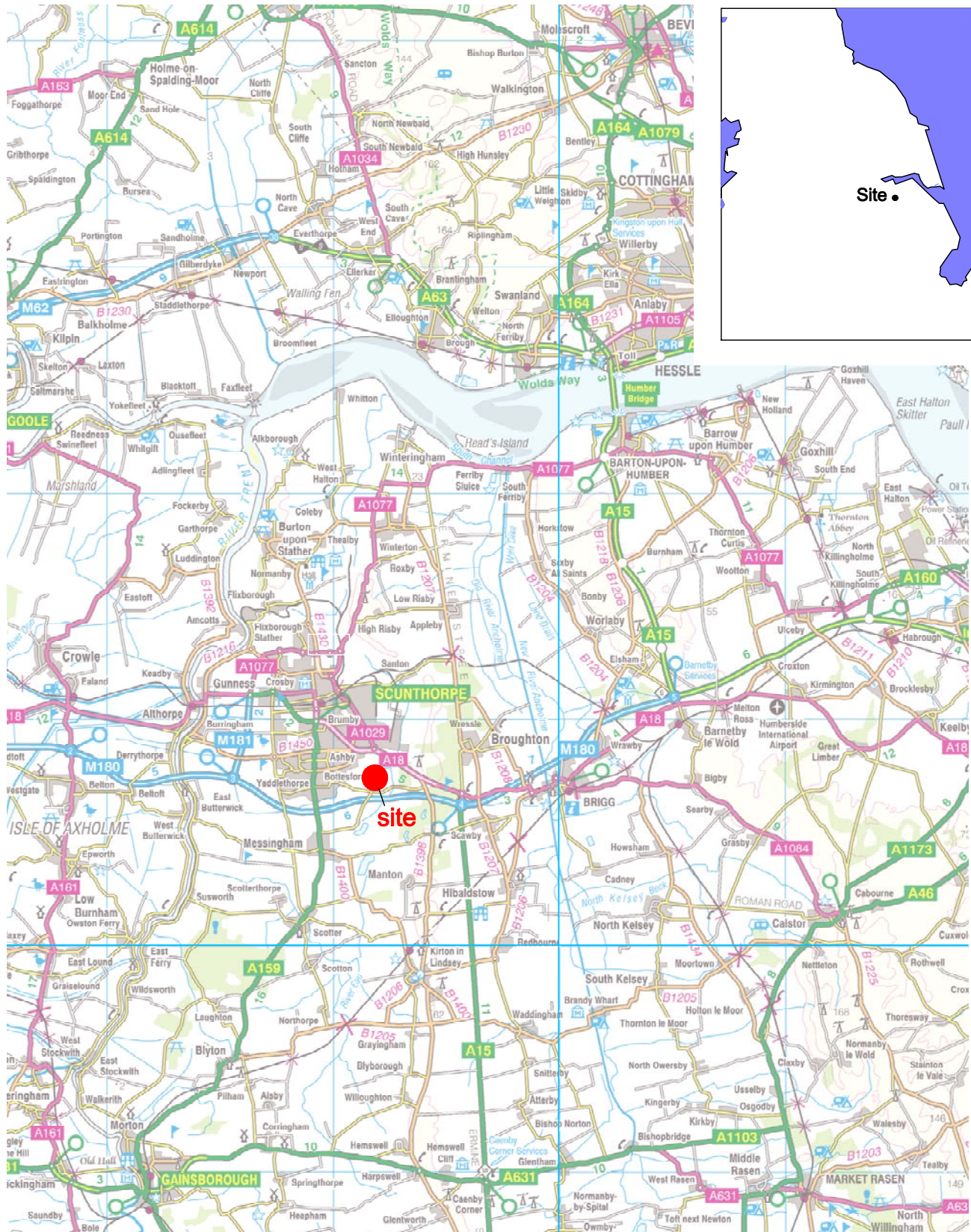

Reproduced from the Landranger 1:100,000 scale by permission of the Ordnance Survey on behalf of The Controller of Her Majesty's Stationery Office. © Crown copyright 1990. All rights reserved. Licence No AL 100005569



0 1000 2000 metres

Figure 1: Location Map



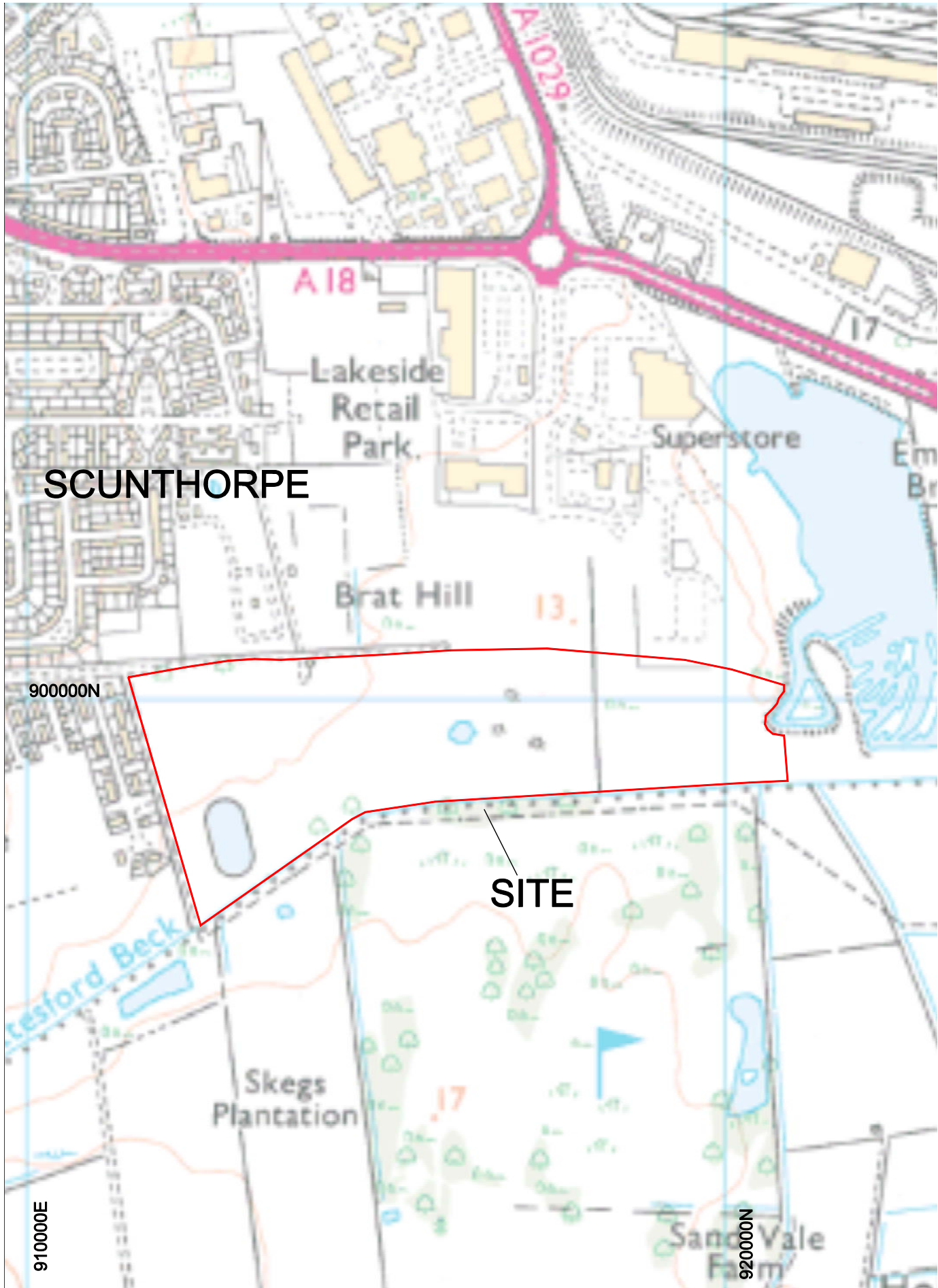

**SCUNTHORPE**

**SITE**

↑  
 N Reproduced from the Landranger 1:25,000 scale by permission of the  
 Ordnance Survey on behalf of The Controller of Her Majesty's Stationery  
 Office. © Crown copyright 1990. All rights reserved.  
 Licence No AL 100005569

0 ——— 1m  
 Scale 1:1000 at A4



Figure 2: Site Location Map

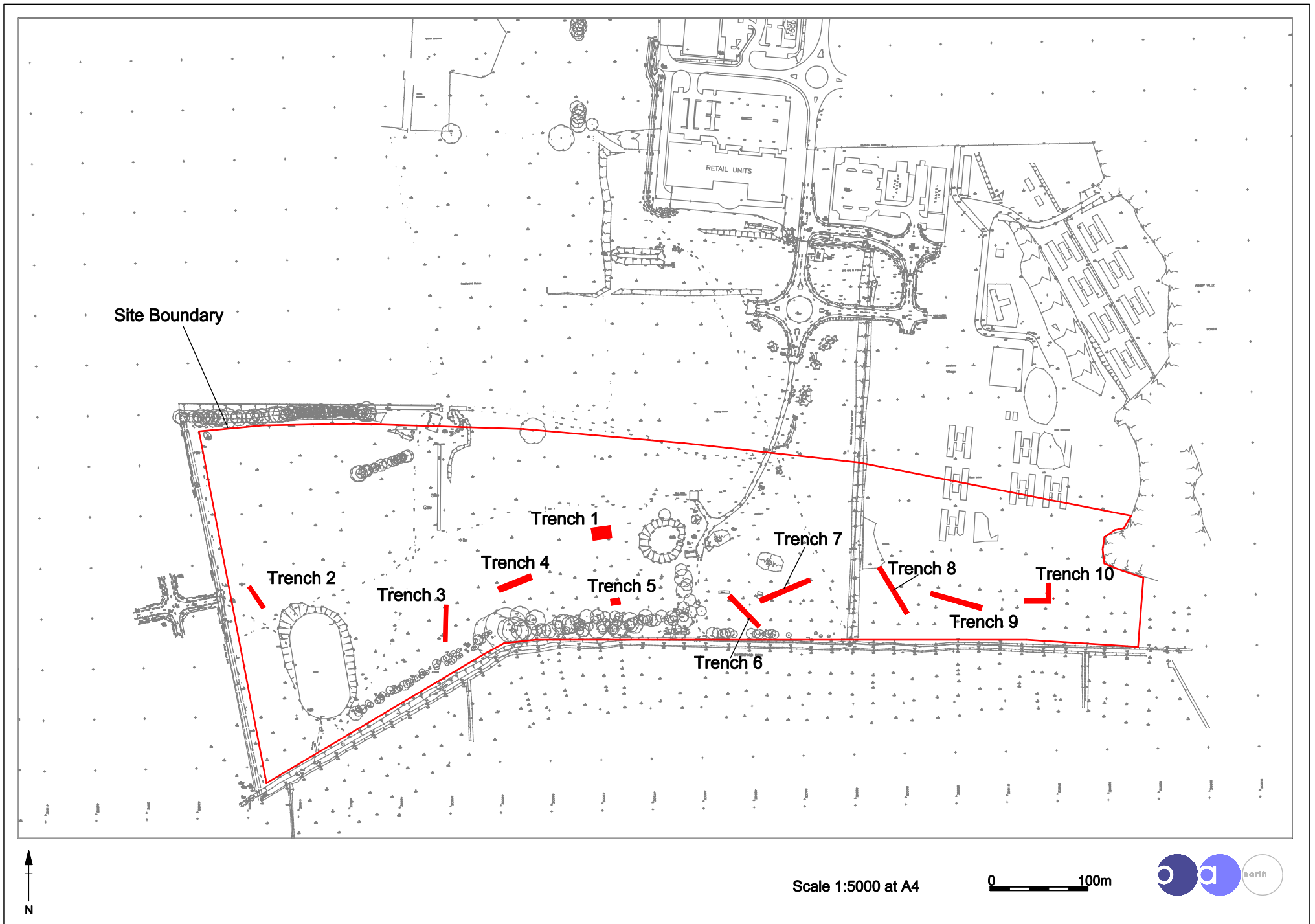

Figure 3: Trench Location Plan

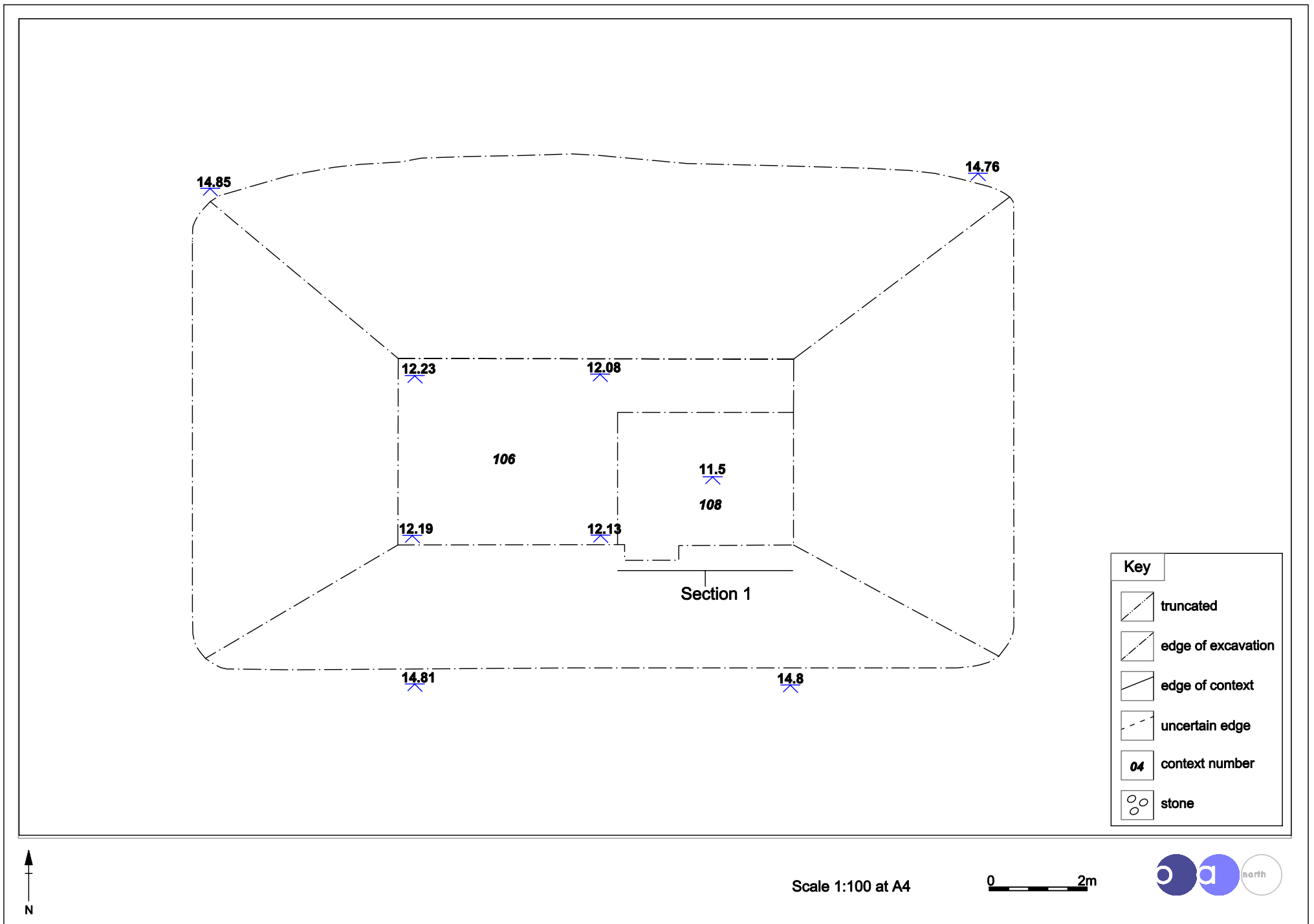

Figure 4: Plan of Trench 1

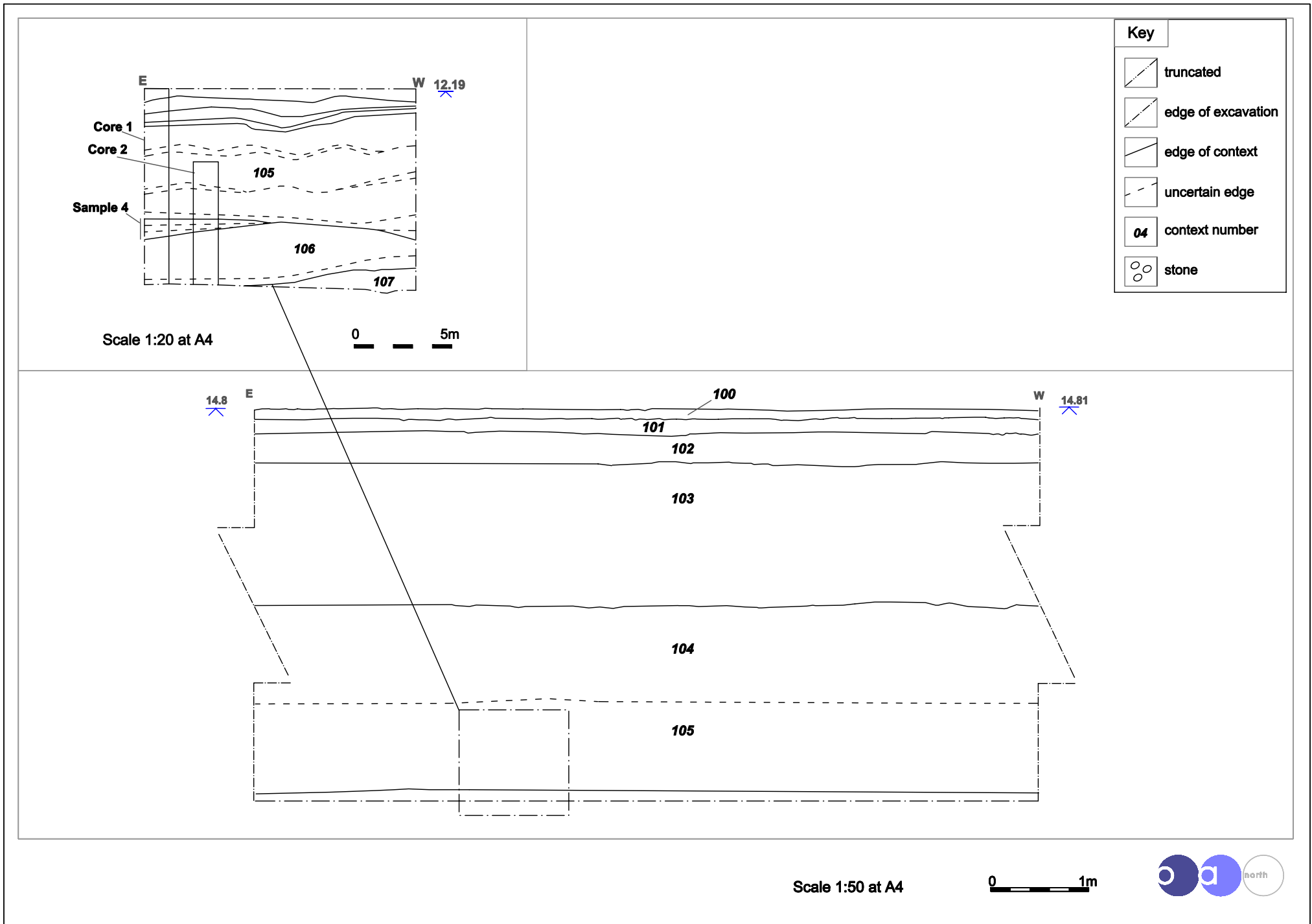
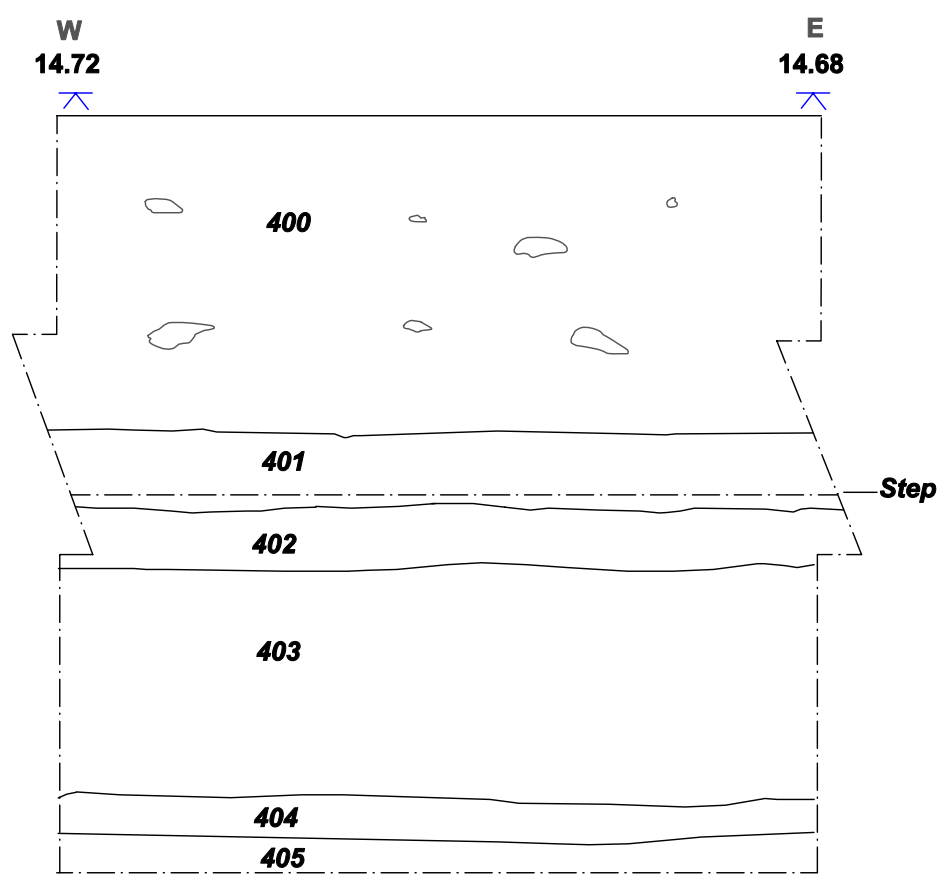

Figure 5: North-facing sample section through Trench 1, inset shows deposits examined by monolith cores 1 and 2.



Key	
	truncated
	edge of excavation
	edge of context
	uncertain edge
	context number
	stone



Scale 1:20 at A4

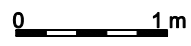

Figure 6: South-facing sample section through Trench 4.

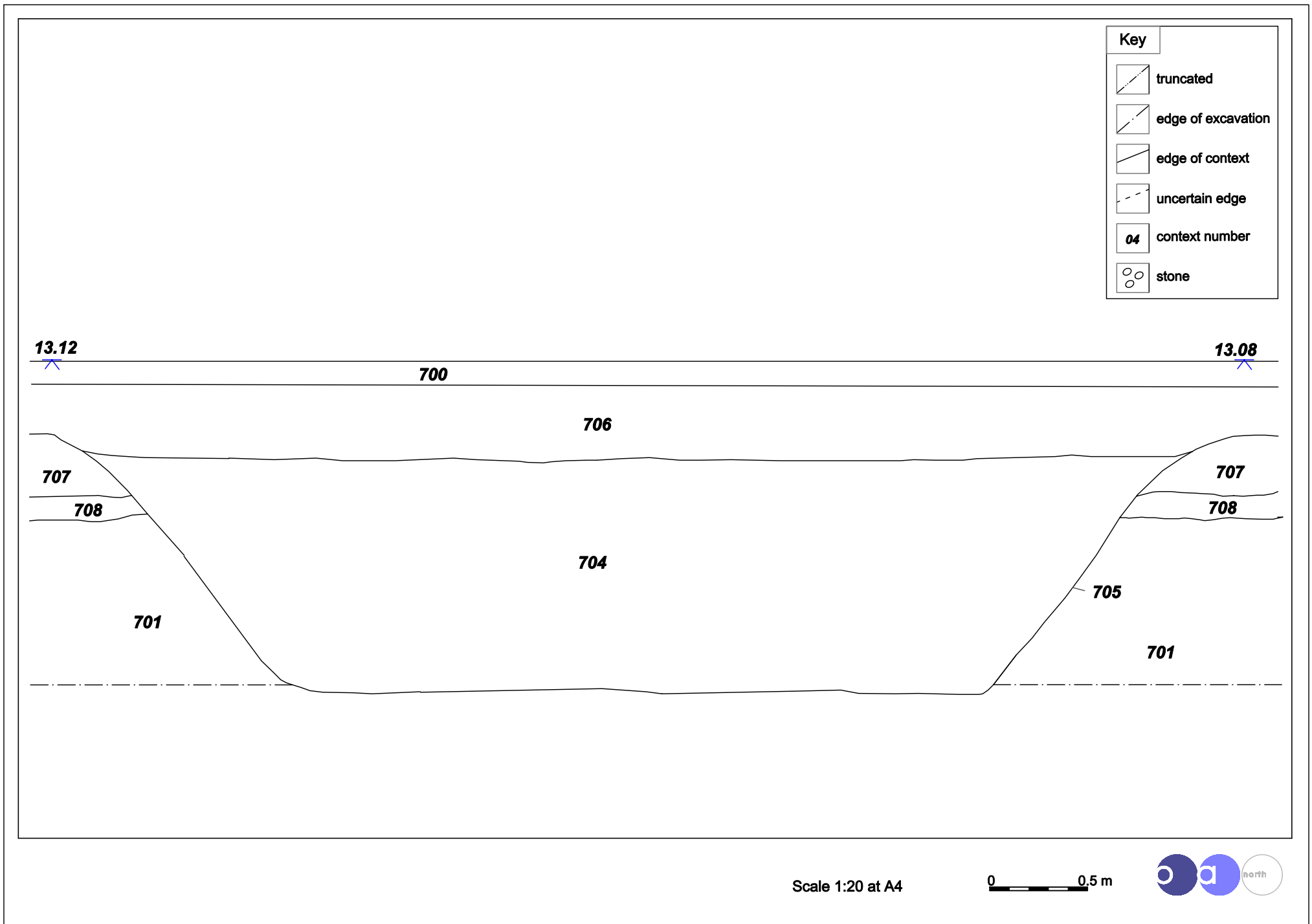

Figure 7: North-north-west-facing section through ditch 705, Trench 7.

Figure 8: Plan of Trench 7



0 1.5m

Scale 1:75 at A3

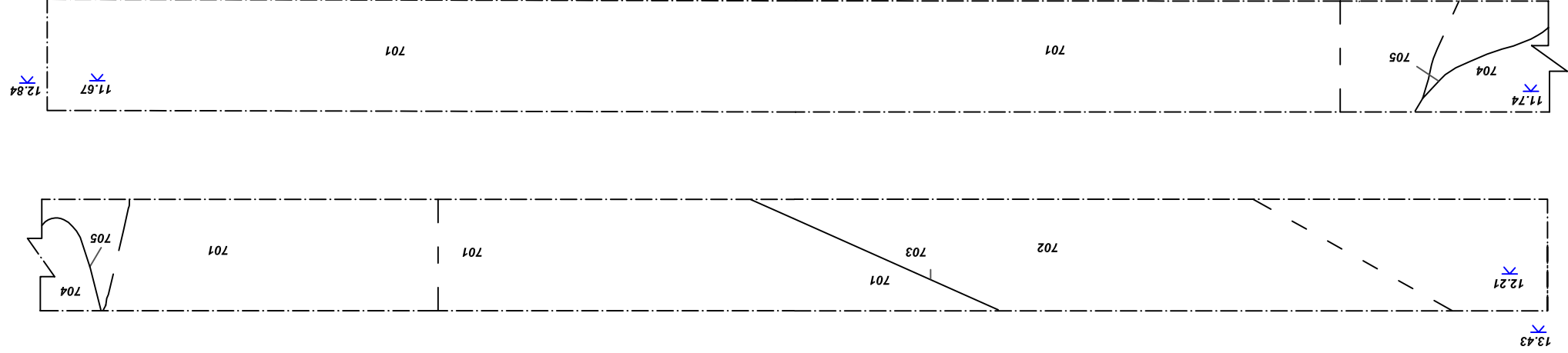

Key	
	truncated
	edge of excavation
	edge of context
	uncertain edge
	context number
	stone



Plate 1: General View of Trench 1 following recording and preparation of section for monolith sampling



Plate 2: North-facing section in Trench 1 prior to taking of monolith samples



Plate 3: Trench 5, facing east



Plate 4: Oblique view of ditch 803 in north-facing section of Trench 8





Plate 5: North-west-facing section within Trench 9



Plate 6: Half section through circular feature in Trench 10

## APPENDIX 1: SPECIFICATION

---

**A Specification for an Archaeological Evaluation of a Proposed Spine Road  
on Land at Lakeside, Scunthorpe, North Lincolnshire**

**Contents**

<i>Summary</i>	2
1.0 Introduction.....	3
2.0 Methodology.....	8
3.0 Timetable and Personnel.....	11
4.0 Insurance.....	12
5.0 Health and Safety.....	12
6.0 References	12
7.0 Figures.....	13
Figure 1. Site Location, 1:25000	
Figure 2. Borehole locations	
Figure 3. Location of the former sewage works	
Figure 4. Proposed trial-trench locations	



## **Summary**

*Lakeside Partnership Ltd. are proposing part of a residential development in the form of a spine road and associated roundabout and drainage services, within the Lakeside development area, situated on the south-east side of Scunthorpe in North Lincolnshire (Application No.2002/1407). The site is located at Brat Hill, between the A18 and the Bottesford Beck and is centred on NGR SE 9165 0826. John Samuels Archaeological Consultants (JSAC) have been commissioned to undertake an archaeological evaluation of the western half of the proposed spine road in advance of development. North Lincolnshire Council has granted full planning permission for the development, subject to a standard paragraph 30 archaeological condition (PPG 16).*

*A number of isolated archaeological discoveries were made within the area of the proposed spine road development in the 1930s, during the construction of a former sewage works on the site. They comprise two find-spots of Mesolithic and later flints; and two find-spots of Romano-British pottery. The Lakeside development site lies within an area of archaeological potential: many prehistoric stone tools have been recovered from the sandy warrens around Scunthorpe; and a series of late Iron-Age and Romano-British enclosures have recently been identified to the west of Lakeside (NLSMR).*

*Much of the Lakeside site was extensively disturbed in the early 20th century by opencast ironstone mining and by the construction of the sewer works. The latter, which included a series of large tanks and filter beds, coincides exactly with the line of the western half of the proposed spine road and the current evaluation area. However, in areas of previous impact, it is possible that archaeological deposits survive beneath the deep cover sands that are typical of the area and that are known from recent ground investigations to underlie the current site.*

*This document proposes a methodology for undertaking an archaeological evaluation of the western half of the proposed spine road, and associated roundabout and drainage services, in the form of trial trenching. The evaluation comprises the excavation of ten large trenches, carefully positioned to investigate areas of impact, highlighted by a detailed study of the road development proposal plans. The evaluation also takes into account the findings of the desk-based assessment; and the potential for surviving areas of archaeology, indicated by a previous watching brief; analysis of past impact and by the results of recent ground investigations. The document has been produced by Karen Francis BA in consultation with Simon Mortimer MA (Oxon) MIFA of JSAC, on behalf of Lakeside Partnership Ltd. and is subject to the approval of the Curatorial Archaeologist.*

## **1.0 Introduction**

### **1.1.1 Site Location and Description**

- 1.1.1 Lakeside Partnership Ltd. are proposing part of a residential development in the form of a spine road and associated roundabout and drainage services, within the Lakeside development area, situated on the south-east side of Scunthorpe in North Lincolnshire (Application No.2002/1407). The site is located at Brat Hill, between the A18 and the Bottesford Beck and is centred on NGR SE 9165 0826. The spine road represents a single phase of development within the 40 ha. Lakeside residential development site. John Samuels Archaeological Consultants (JSAC) have been commissioned to undertake an archaeological evaluation of the western half of the proposed spine road in advance of development.
- 1.1.2 The Lakeside development site is located at Brat Hill, between the A18 road and the Bottesford Beck on the south-eastern side of Scunthorpe in North Lincolnshire and is centred on NGR SE 9165 0826 (Figure 1). The area of the proposed road lies at an average height of approximately 15 m AOD, and slopes down towards Bottesford Beck, which forms the southern boundary of the site. The western site boundary is formed by the existing residential development of Wisteria Way and by Brat Hill Farm caravan site. The Lakeside Retail Park and the edge of a large balancing pond define the eastern boundary. The A18 highway forms the northern boundary of the site.
- 1.1.3 The soils on the site are classed as unsurveyed: urban and industrial areas (SSEW, sheet 4, 1:250,000, 1983). A ground investigation report produced by WSP in 2002 reported that the site is underlain by recent Blown Sand, overlying the Frodingham Ironstone of the Lower Lias of Jurassic Age.
- 1.1.4 The site is covered with scrub-type vegetation typical of derelict land, although exposed areas of sand are visible, as are the remnants of previous use, including areas of tarmac, re-worked sand, substantial drains and rubble (JSAC 971/02/01). A concrete-lined pond is located in the south-west corner of the site.
- 1.1.5 A ground investigation was carried out across the whole 40 ha Lakeside development site in January 2002 by WSP environmental. The works comprised the excavation of eight cable-percussion boreholes and fifty-six mechanically excavated trial pits. The geology was recorded as comprising predominantly loose sand, locally with layers of soft peaty clays. The natural strata were overlain generally by less than 1 metre of made ground. Groundwater was recorded at shallow depth in many of the exploratory holes (WSP 2002, iii.). A supplementary ground investigation specifically associated with the proposed spine road embankment was undertaken in 2003. A number of exploratory holes are directly associated with the area of the proposed spine road and associated balancing pond and floodplain (Figure 2). The majority of these were found to contain topsoil deposits up to 0.20 m

deep, overlying made ground to a maximum depth of 1.80 m and/or sand deposits. The exploratory holes associated with the road development are summarised in table 1 below.

## **1.2 Planning Background**

- 1.2.1 In 2002, Lakeside Partnership Ltd. made a planning application to North Lincolnshire Council (NLC) for part of a residential development, comprising a 720 m-long spine road and associated roundabouts, drainage services, floodplain area and balancing-pond extension within the Lakeside residential development area (Application No. 2002/1407).
- 1.2.2 In December 2002 an archaeological brief was issued by North Lincolnshire Council Sites and Monuments Record Office (NLSMR) for a watching brief during groundworks. The brief was valid for one year and no works were carried out.
- 1.2.3 In July 2003, full planning permission was granted by NLC, subject to conditions. Condition 4 included a standard paragraph 30 archaeological condition (PPG 16), which requested that,

*‘No development shall take place until the applicant has secured the implementation of a programme of archaeological work in accordance with a written scheme of investigation which has been submitted by the applicant and approved in writing by the local planning authority. The scheme shall provide for:*

- (i) the proper identification and evaluation of the extent, character and significance of archaeological remains within the application area;*
- (ii) an assessment of the impact of the proposed development on the archaeological remains;*
- (iii) proposals for the preservation in situ, or for the investigation, recording and recovery of archaeological remains and the publishing of the findings, it being understood that there shall be a presumption in favour of their preservation in situ wherever feasible;*
- (iv) sufficient notification and allowance of time to archaeological contractors nominated by the developer to ensure that archaeological fieldwork as proposed in pursuance of (i) and (ii) above is completed prior to the commencement of permitted development in the area of archaeological interest; and*
- (v) notification in writing to the North Lincolnshire Sites and Monuments Record Office of the commencement of archaeological works and the opportunity to monitor such works.*

*Reason: The site lies in an area of archaeological interest.’*

<b>Trial pit / Borehole No:</b>	<b>TP 3a</b>	<b>TP 5a</b>	<b>(TP 6a)</b>	<b>TP 13</b>	<b>TP 14</b>	<b>TP 15</b>	<b>TP 20</b>	<b>TP 21</b>	<b>TP 28</b>	<b>TP 29</b>	<b>TP 30</b>	<b>(TP 31)</b>	<b>(TP 42)</b>	<b>BH 4</b>	<b>BH 5</b>	<b>BH 6</b>
<b>Topsoil</b>	0-0.10		0-0.10	0-0.10	0-0.10	0-0.15	0-0.10	0-0.30	0-0.10	0-0.10		0-0.05	0-0.10	0-0.20	0-0.20	0-0.20
<b>Made Ground</b>		0-0.50	0.10-1.80			0.15-0.30	0.10-2.60		0.10-1.05	0.10-0.50	0-1.00	0.05-1.50	0.10-1.40	0.20-0.40	0.20-0.40	
<b>Relict topsoil</b>		0.50-0.60									1.00-1.20					
<b>Sand</b>	0.10 - 2.00	0.60-1.80		0.10-0.50	0.10-0.30	0.30-2.80		0.30-1.20		0.50-2.60	1.20-3.30	1.50-3.10	1.40-2.10	0.40-3.80	0.40-2.00	0.20-1.20
<b>Peat</b>		1.80-1.90														
<b>Lower sand</b>	2.00 - 2.60			0.50-2.70	0.30-2.60			1.70-2.80							2.00-2.40	
<b>Clay</b>		1.90-3.00						1.20-1.70		2.60-3.30			2.10-3.20	3.80-4.60	2.40-3.10	1.20-1.60
<b>Mudstone</b>											3.30-3.40	3.10-3.20	3.20-3.30	4.60-4.65	3.10-3.15	1.60-2.30
<b>End depth</b>	2.60	3.00	1.80	2.70	5.50		2.80		1.05	3.30	3.40	3.20	3.30	4.65	3.15	2.30
<b>Comments</b>		Gravel and CBM in made ground	Concrete slab at 1.00 m	Running sand locally below 2.4 m	Strata damp and locally collapsing below 1.7 m	Strata wet and locally collapsing below 1.5 m	c. 1900 AD bottle dump at 2 m.	Trial pit sides continually collapsing below 2m	Trial pit abandoned due to reinforced concrete at 1.05	Slag in made ground	Slag & concrete in made ground	Slag & concrete in made ground	Slag & concrete in made ground	Groundwater encountered below 2.5 m	Poss. Ironstone at lowest 0.05 m	

**Table 1. Summary of the WSP ground investigations associated with the area of the western spine road**

( ) = Area of proposed balancing pond



- 1.2.4 In June 2005 an outline brief for a staged scheme of archaeological evaluation was issued by NLSMR. The brief is valid for one year. JSAC have been commissioned to undertake the current evaluation in advance of the road development.
- 1.2.5 Only the western half of the proposed spine road is required to be evaluated. This part of the development covers an area of 3.6 ha and involves:
- The construction of a 420 m-stretch of road extending between Wisteria Way/roundabout 3 and an existing circular balancing pond/roundabout 2. The road is to be built at existing ground level, following the removal of 100 mm of topsoil and vegetation;
  - the enlargement of an existing circular balancing pond to the north of the road, which will be extended westwards by *c.* 127 m and excavated to a maximum depth of *c.* 4 m;
  - the construction of a number of main service trenches through and alongside the line of the road, to depths of between 1.50 m and 2.80 m within the area to be evaluated.
  - the creation of a 650 m-long floodplain area between the road and Bottesford Beck, which will be excavated to a maximum depth of *c.* 0.90 m and contained by embankments and ditches.

### **1.3 *Archaeological and Historical Background***

- 1.3.1 Prehistoric and Romano-British finds are known from the site. An archaeological desk-based assessment carried out in August 2002 (JSAC 971/02/01) highlighted twenty SMR entries within a kilometre of the proposed development site. Four of these entries were located within the current area of evaluation and included the following:
- LS1866: a find-spot of Romano-British pottery (NGR SE 9153 0795)
  - LS1897: a find-spot of Romano-British pottery (NGR SE 9142 0804)
  - LS1960: a find-spot of Mesolithic and later flints at South Grange Farm (NGR SE 9126 0792). These included scalene triangles, shouldered points and conical cores but no micro-burins (Dudley 1949, 39)
  - LS4645: a find-spot of unspecified flints (NGR SE 913 078)
- 1.3.2 A watching brief was carried out in 1995 by Humberfield Archaeology, during the construction of the existing, circular balancing pond (NLSMR). The watching brief revealed an area of raised ground of up to 2 m, associated with made ground, across the area of the current proposed balancing-pond extension. The watching brief also revealed that the majority of the southern half of the area of the circular balancing pond had been subjected to considerable disturbance by the construction of the sewage works. In contrast, the northern half of the pond area contained over 2 m of stratified deposits, which contained organic material but no archaeological finds or features,

although excavation was restricted in depth and by the proximity of working machinery. The excavated deposits comprised:

- 0.4 m – 0.50 m made ground
- 0.4 m – 0.50 m brown sand
- 0.30 m dark brown/black organic material
- 0.75 m yellow sand
- 0.30 m plastic silty clay with laminates and pockets of organic material
- Stained blue-grey gritty sand of unknown depth

1.3.3 The 2002 desk-based assessment highlighted the substantial and extensive evidence for prehistoric and Roman activity known in the area generally (see for example, May 1976, who noted the remarkable density of Mesolithic sites in the Scunthorpe area; as well as Dudley 1949). Discoveries of stone tools are especially well known from the sandy warrens around Scunthorpe; and Romano-British sites are particularly prolific on the limestone edge (NLC Local Plan 2003, 14.4).

1.3.4 Historically, the Lakeside site lies within the former township of Ashby, which along with Burringham, Holme and Yaddlethorpe formed part of the extensive parish of Bottesford. Ashby was created as a separate civil parish in 1866 but was subsumed within the creation of Scunthorpe in 1919 (JSAC 971/02/01).

1.3.5 The eastern half of the proposed road (*c.* 300 m), located between the balancing pond and the Lakeside Retail Park is not included in the current evaluation. This area is known from historical maps to have been severely impacted by opencast ironstone mining during the early twentieth century (JSAC 971/02/01). These mine workings were backfilled with up to 8 m of very loose sand and are recorded as a former landfill site (WSP 2002, iii; iv.).

1.3.6 The desk-based assessment concluded that much of the proposed development site had been significantly impacted by twentieth-century mineral workings and sewer works. Twentieth-century OS maps of the sewer works show that their location clearly coincides with the current area of evaluation (Figure 3). The sewer works were constructed in the 1940s and remained in operation until the 1980s. The works consisted of a series of large tanks, filter beds and sludge beds. The recent ground investigations carried out by WSP suggest that some of the concrete foundations may survive at depth within the made ground.

## **1.4 Aims and Standards**

1.4.1 The desk-based assessment at Lakeside, Scunthorpe established that parts of the site at Lakeside could have some potential for archaeological remains. The primary objective of the evaluation is to confirm the presence or absence and significance of any archaeological remains.

1.4.2 The proposed locations of the ten trial trenches take three principal factors into account:

- Areas of impact associated with the road development, indicated by a detailed study of the proposed development plans;
- The findings of the desk-based assessment (JSAC 971/02/01);
- The potential for surviving areas of archaeology, indicated by a previous watching brief; analysis of past impact and by the results of recent ground investigations.

1.4.3 Should remains of archaeological interest be exposed, subsidiary aims are to:

- establish their extent, depth, character, quality, function, state of preservation and date;
- provide further information on the historic character of the development site;
- assess the artefactual and environmental potential of the archaeological features and deposits encountered;
- place the remains within their local, regional and national context;
- to produce a site archive for deposition with an appropriate museum and to provide information for accession to the local SMR.

1.4.4 When (all stages of) the evaluation is/are completed, an informed decision can then be taken regarding the future treatment of the remains and any mitigatory measures appropriate, either in advance of and/or during development.

1.4.5 This specification conforms to the requirements of *Planning Policy Guidance: Archaeology and Planning* (DoE 1990) (PPG 16). It has been designed in accordance with current best archaeological practice and the appropriate national standards and guidelines including:

- *Management of Archaeological Projects 2<sup>nd</sup> Edition* (English Heritage, 1991);
- *Model Briefs and Specifications for Archaeological Assessments and Field Evaluations* (Association of County Archaeological Officers, 1994);
- *Code of Conduct* (Institute of Field Archaeologists, 2000); and
- *Standard and Guidance for Archaeological Field Evaluations* (Institute of Field Archaeologists, 1994. Revised 2001);
- *The Historic Environment, Policy HE9: Archaeological Evaluation. North Lincolnshire Local Plan. pp. 207* (adopted May 2003).

## **2.0 Methodology**

### **2.1 Evaluation**

2.1.1 The evaluation will include the excavation of a total of ten trial trenches located within the area of the balancing pond extension; along the line of the proposed service trenches; and within the eastern part of the proposed



floodplain. The exact trench locations are shown in Figure 4. The proposed western spine road (covering 10,000 m<sup>2</sup>) will be constructed directly above the existing ground surface following the removal of 100 mm of vegetation, and will not involve significant impact. It is therefore proposed to concentrate the evaluation on these three areas of impact associated with the development:

- The proposed enlargement of the existing circular balancing pond to the north of the road. This will impact on an area of *c.* 5,200 m<sup>2</sup> and to a maximum depth of *c.* 4 m below current ground level. It is proposed to excavate one 8 m x 16 m stepped trial trench with an internal trench plan of 10 m x 2 m, to the immediate west of the existing circular balancing pond. The stepped trench would allow a depth of up to 4 m to be evaluated, enabling any archaeological deposits or features below blown sand to be assessed to the maximum depth of development impact. Excavation will cease at either solid natural geology (i.e. not sand), or when archaeological deposits or features are identified, or at 4 m. The results of the watching brief carried out in 1995 in the area of the existing, circular balancing pond suggests that organic deposits could be encountered below made ground and sands at depths of *c.* 1.3 m and *c.* 2 m (see section 1.3.2).
- The alignment of the principal sewers and drains associated with the western half of the spine road, which will have a maximum impact of *c.* 2 m. It is proposed to excavate four, 30 m x 2 m trial trenches along the line of the drains. The trenches will be stepped to a maximum depth of 2 m below current ground level, in order to assess to the maximum depth of development impact. Excavation will cease at either solid natural geology (i.e. not sand), or when archaeological deposits or features are identified, or at 2 m.
- The proposed 650 m-long floodplain, aligned east/west, situated between the road and the Bottesford Beck, which will impact to a maximum depth of *c.* 0.90 m. The eastern half of the floodplain development incorporates an area of archaeological potential (Area 2) identified by the 2002 desk-based assessment (JSAC 971/02/01). A number of geotechnical trial pits conducted by WSP in the eastern half of the floodplain in 2002 revealed contrasting results, including areas of significant made ground to a depth of 2.60 m; and areas comprising up to 5.5 m of topsoil and sand (see Table 1 above). It is proposed to excavate five 50 m x 2 m trial trenches within the eastern half of the floodplain. The trenches will be excavated to a maximum depth of 1.2 m below current ground level, in order to assess to the maximum depth of development impact. Excavation will cease at either solid natural geology (i.e. not sand), or when archaeological deposits or features are identified, or at 1.2 m. The trial trenches have been positioned to avoid known areas of made ground.

2.1.2 The trenches will be opened and the topsoil and any recent overburden removed using an appropriate mechanical excavator, compressed air tools, or electrical breakers. If a mechanical excavator is used, a toothed bucket may be used to

assist the removal of any concrete, tarmac or hardcore; thereafter, a wide, toothless ditching blade shall be used wherever possible. The spoil generated during the evaluation will be mounded away from the edges of each trench and topsoil and subsoil should be stored separately. Mechanical, air-powered, or electrical excavation equipment shall be used judiciously under direct archaeological supervision. Excavation will cease at either solid natural geology (i.e. not sand), or when archaeological deposits or features are identified, or at the maximum specified depth. The nature of any archaeological deposits or features will be assessed by hand excavation. Any identified sand deposits will be excavated by machine to a safe depth, normally 1.2 m beneath current ground level, but extending to a maximum of 2 m below current ground level within the four stepped trial trenches associated with the drains; and to a maximum of 4 m below current ground level within the proposed stepped trench associated with the balancing pond extension (see section 2.1.1 and Figure 4). The stepped trenches are intended to evaluate to the maximum depth of impact, enabling any potential archaeological deposits or features below blown sand to be assessed. All trenches must be accurately surveyed and related to the National Grid.

- 2.1.3 Each trench will be cleaned by hand and discrete archaeological features (e.g. pits) that are identified for excavation will be assessed by half- or quarter-sectioning. At least 50% of all contained features will be excavated. As a minimum (where possible) a 1 m-wide section of each linear feature will be excavated by hand. Should this initial investigation not answer the aims set out in Section 1.4.1 then consideration will be given to further investigation by hand or by machine, following discussions with the Curatorial Archaeologist.
- 2.1.4 The trenches will be recorded at an appropriate scale by measured plans at 1:50 or 1:20 scale. The sections of excavated archaeological features will also be recorded by measured drawing at a scale of 1:10. The deposits encountered will be fully described on pro-forma individual context recording sheets. The recording system is based on the Museum of London's *'Archaeological Site Manual'* (1994). Spot heights and those of individual features will be recorded relative to Ordnance Datum and the site grid must be accurately related to the National Grid.
- 2.1.5 A photographic record with a minimum format of 35 mm (in monochrome and colour) will be maintained during the course of the fieldwork and will include:
- the site prior to commencement of fieldwork;
  - the site during work, showing specific stages of fieldwork;
  - the layout of archaeological features within each trench;
  - individual features and, where appropriate, their sections;
  - groups of features where their relationship is important.
- 2.1.6 All artefacts will be treated in accordance with UKIC guidelines, *First Aid for Finds* (1998). All finds will be bagged and labelled according to the individual deposit from which they were recovered, ready for later cleaning and analysis. In accordance with the procedures outlined in MAP2, all iron objects, a selection of non-ferrous artefacts (including all coins) and a sample of

any industrial debris relating to metallurgy will be X-radiographed before assessment.

2.1.8 The environmental sampling strategy will include the routine sampling of deposits for retrieval and assessment of the preservation conditions and potential for analysis of all biological remains, and will be developed in collaboration with a recognised bioarchaeologist. Samples will be taken for scientific dating (principally radiocarbon dating), where dating by artefacts is insecure, and where dating is necessary for development of the Project Design/Brief for subsequent mitigation strategies. Where *in situ* timbers are found to survive in good condition, samples will be taken for dendrochronological determination following procedures presented in the English Heritage document *Dendrochronology: guidelines on producing and interpreting dendrochronological dates*. A suitable specialist will, if necessary, make a site visit to advise on deposits suitable for environmental sampling. In addition, any securely dated deposits containing the following will be sampled, at a minimum of 30 litres wherever possible.

- charred plant remains;
- large quantities of molluscs;
- large quantities of bone;
- hearths and other burnt features;
- other domestic features, e.g. house gullies, potentially containing the above.

2.1.9 Charred plant samples will be wet sieved with flotation using a 0.5 mm mesh. All residues will be checked.

2.1.10 Should waterlogged deposits be encountered, further consultation with a suitable specialist will determine methods for recovery.

2.1.11 Any human remains encountered will be cleaned with minimal disturbance, recorded and left *in situ* and only removed if necessary. The contractor will comply with all statutory consents and licences under the Disused Burial Grounds (Amendment) Act, 1981 or other Burial Acts regarding the exhumation and interment of human remains. The archaeological contractor will comply with all reasonable requests of interested parties as to the method of removal, re-interment or disposal of the remains or associated items. Every effort will be made, at all times, not to cause offence to any interested parties.

2.1.12 The Curatorial Archaeologist will be given notice of when work is due to commence and will be free to visit the site by prior arrangement with the project director. Should any significant remains be found, it may be necessary, in liaison with the Curatorial Archaeologist, to formulate a strategy designed to fully establish their character, distribution, extent, condition, dating and further treatment.

2.1.13 Archaeological staff and visitors will respect Health and Safety provisions and site-specific safety regulations.

2.1.14 The material excavated from the trenches will be used to backfill them following the completion of work. Material will be lightly compacted and no specialist reinstatement will be carried out.

2.1.15 Arrangements for the deposition of all artefacts will be agreed with the landowner prior to the commencement of fieldwork, and with the North Lincolnshire Museums Service.

## **2.2 Post-excavation**

2.2.1 Upon completion of on-site works, the stratigraphic information, artefacts, soil samples and any technological residues will be assessed as to their potential and significance for further analysis. Post excavation work will comprise the following:

- checking of drawn and written records during and on completion of fieldwork;
- production of a stratigraphic matrix of the archaeological deposits and features present on the site, if appropriate;
- cataloguing of photographic material and labeling of slides that will be mounted on appropriate hangers;
- cleaning, marking, bagging and labelling of finds according to the individual deposits from which they were recovered. A rapid scan of all excavated material will be undertaken in collaboration with specialist conservators and finds researchers. All finds will be identified and dated by appropriate specialists. All X-radiographs will be inspected.
- Any finds requiring specialist treatment and conservation will be sent for appropriate treatment. Material considered vulnerable will be selected for stabilisation after specialist recording. Where intervention is necessary, consideration will be given to possible investigative procedures (e.g. glass composition studies, residues on or in pottery, and mineral-preserved organic material). A written assessment of long-term conservation and storage needs will be produced. Once assessed, all material will be packed and stored in optimum conditions, as described in *First Aid for Finds* (Watkinson and Neal, 1998).
- Processing of all samples collected for biological assessment, or sub-samples of them, will be completed. Bulk and site riddled samples from dry deposits will have been processed during excavation, where possible. The preservation state, density and significance of material retrieved will be assessed. Unprocessed sub-samples will be stored in conditions specified by appropriate specialists. Samples for dating will be submitted to laboratories promptly, so as to ensure that results are available to aid development of Briefs for subsequent mitigation strategies. Waterlogged organic materials will be dealt with following English Heritage documents

*Guidelines for the care of waterlogged archaeological leather; and  
Guidelines on the recording, sampling, conservation and curation of  
waterlogged wood.*

- 2.2.2 A report detailing the finds of the evaluation will be prepared within three months of the completion of site works and will consist of:
- a title page detailing site address, site code and accession number, NGR, author/originating body, client's name and address;
  - full contents listing;
  - a non-technical summary of the findings of the evaluation;
  - a description of the topography and geology of the evaluation area;
  - a description of the methodologies used during the evaluation;
  - a description of the findings of the evaluation;
  - site and trench location plans and plans of each of the trenches/areas showing the archaeological features exposed. Trench location plans will be accurately referenced to the National Grid.
  - sections of the excavated archaeological features including OD heights;
  - interpretation of the archaeological features exposed and their context within the surrounding landscape;
  - specialist reports on the ecofactual / artefactual remains from the site, including a conservation assessment report;
  - appropriate photographs of specific archaeological features;
  - a consideration of the importance of the archaeological remains present on the site in local, regional and national terms;
  - Details of the archive location and destination and timetable for deposition.
- 2.2.3 Copies of the evaluation report will be sent to the client for approval and then to the Curatorial Archaeologist and to the SMR in both paper and digital form. A digital copy of the report will also be sent to Ian Panter at English Heritage. The NLSMR will be licensed to use the material for reference purposes, on the understanding that such licence does not cover commercial use of the material by the NLSMR or any third party.
- 2.2.4 The project archive will be prepared according to the recommendations in *Guidelines for the Preparation of Excavation Archives for long-term storage* (UKIC 1990), and *Standards in the Museum Care of Archaeological Collections* (Museums and Galleries Commission 1992). If finds are made of gold or silver these will if possible be archaeologically excavated and removed to a safe place. Such finds will also be reported immediately to the local Coroner (within 14 days, in accordance with the 1997 Treasure Act). Should it not be possible to remove the finds that day suitable security will be arranged.
- 2.2.5 Notes or articles describing the results of the evaluation will be submitted for publication to an appropriate local journal and/or national journals, dependant on the nature of the results.

### **3.0 Timetable and Personnel**

- 3.1 The evaluation is expected to take up to 15 working days using 4-5 staff.
- 3.2 Karen Francis, BA will be in overall charge of the project and will monitor the work on behalf of the client. Details of the evaluation timetable and the CVs of key personnel will be communicated to the Curatorial Archaeologist, a minimum of one week prior to the commencement of on-site works.

### **4.0 Insurance**

- 4.1 The archaeological contractor will produce evidence of Public Liability Insurance to the minimum value of £5m and Professional Indemnity Insurance to the minimum of £2m.

### **5.0 Health and Safety**

- 5.1 All works will be in compliance with the Health and Safety at Work Act (1974) and all applicable regulations and Codes of Practice.
- 5.2 All archaeological staff will undertake their operations in accordance with safe working practices.
- 5.3 A site-specific risk assessment will be undertaken and recorded prior to the commencement of work on site.
- 5.4 A continuous process of dynamic risk assessment will be undertaken and if significant hazards are identified a specific risk assessment will be undertaken and recorded. Control measures will be implemented as required in response to specific hazards.
- 5.5 Safe working will take priority over the desire to record archaeological features or remains, and where it is considered that recording is dangerous, any such features or remains will be recorded by photography, at a safe distance.

### **6.0 References**

JSAC 971/02/01. 2002. *An archaeological Desk-based Assessment of Lakeside, Scunthorpe, North Lincolnshire*. Unpublished report produced on behalf of Lakeside Partnership Ltd.

SSEW 1983. *Soil Survey of England and Wales*. Sheet 4.

WSP ENVIRONMENTAL LTD. 2002. *Phase I and II Ground Investigation Report: Lakeside, Scunthorpe*. Unpublished report produced on behalf of Clugston Developments Ltd.

## **7.0 Figures**

## APPENDIX 2: FINDS SUMMARY

All finds were recovered from ditch fill **704**

Material	Quantity	Description	Date range
Glass	1	Complete light turquoise sauce bottle, square cross-section, lip moulded separately to body, embossed text on side 'Garton's HP Sauce', '2' on base, closure type: mushroom-shaped glass stopper with cork washer (neither present)	1903 <sup>1</sup> – 1940s <sup>2</sup> ?
Ceramic	3	Self-glazed buff-coloured stoneware jam or marmalade jars (2 rim to base, 1 base – from 3 different vessels), all bases unmarked, vertical grooves on sides, groove near rim for tie-on lid	Mid nineteenth – early twentieth century
Ceramic	1	White earthenware bowl rim with blue slip bands and stripes (factory-produced)	Nineteenth – early twentieth century
Ceramic	1	White earthenware soap dish lid, relief-moulded and with painted enamels	Late nineteenth – early twentieth century
Ceramic	1	Self-glazed orange earthenware pancheon rim, interior white slip-coated, and white slip band on rim	Nineteenth – early twentieth century
Ceramic	1	Self-glazed buff-coloured stoneware bottle (only chip missing off rim), unmarked	Nineteenth – early twentieth century

<sup>1</sup> HP Sauce was launched in 1903 (HP Foods n.d.), however there is a slim possibility that it could be before this date, since Mr Garton had been producing HP sauce from an unknown date prior to selling the recipe to Edward Sampson Moore of the Midland Vinegar Company Ltd (*ibid*), and the fact that the lip is applied separately indicates a date of 1872 onwards (Fletcher 1972, 55). Had the lip been integral to the mould a definite twentieth century date would have been indicated (*ibid*).

<sup>2</sup> A similar light turquoise HP Sauce bottle has been dated to c1930-40 (Blakeman 2002, 32)



## APPENDIX 3: SUMMARY CONTEXT LIST

<b>Context</b>	<b>Trench</b>	<b>Description</b>
100	1	Topsoil
101	1	Grey clay levelling layer
102	1	Brownish-yellow silty clay levelling layer
103	1	Dark grey slag
104	1	Fine yellow aeolian sands
105	1	Laminated fluvial sands
106	1	Peat
107	1	Golden yellow silty gravel
108	1	Blue grey silty gravel
109	1	Very compact blue grey gravel
200	2	Topsoil
201	2	Brownish-orange sandy gravel silt
202	2	Brownish-yellow grey sandy silt
203	2	Yellow white sand
204	2	Orange-brown sandy silt
205	2	Buried tarmac
300	3	Topsoil
301	3	Slag
302	3	Brownish-yellow redeposited sand
303	3	Yellow sand
400	4	Stiff Grey clay
401	4	Brown sand
402	4	Relict brown silty sand topsoil
403	4	Pale yellow laminated sands
404	4	Peat
405	4	Grey-blue fine sandy silt
500	5	Topsoil
501	5	Slag
502	5	Mid-brownish-orange sand
503	5	Peat
504	5	Yellow white sand
600	6	Topsoil
601	6	Pale yellow sand
700	7	Topsoil
701	7	Sand
702	7	Fill of ditch 703

<b>703</b>	7	Post-medieval ditch
<b>704</b>	7	Fill of ditch <b>705</b>
<b>705</b>	7	Ditch
<b>706</b>	7	Levelling layer above <b>704</b>
<b>707</b>	7	Orange sand
<b>708</b>	7	Peat
<b>800</b>	8	Topsoil
<b>801</b>	8	Orange sand
<b>802</b>	8	Fill of ditch <b>803</b>
<b>803</b>	8	Ditch
<b>804</b>	8	Fill of ditch <b>805</b>
<b>805</b>	8	Ditch
<b>806</b>	8	Fill of ditch <b>809</b>
<b>807</b>	8	Fill of ditch <b>809</b>
<b>808</b>	8	Fill of ditch <b>809</b>
<b>809</b>	8	Ditch
<b>810</b>	8	White sand
<b>900</b>	9	Topsoil
<b>901</b>	9	Peat
<b>902</b>	9	Interface between peat and sand
<b>903</b>	9	Sand
<b>1000</b>	10	Topsoil
<b>1001</b>	10	Yellow sand
<b>1002</b>	10	Peat
<b>1003</b>	10	White sand
<b>1004</b>	10	Fill of <b>1005</b>
<b>1005</b>	10	Shallow circular feature