

BUILD.
98/20

(BU)

Environment Agency

Berry Hill Ice-house, Maidenhead, Buckinghamshire
ARCHAEOLOGICAL RECORDING IN ADVANCE OF DEMOLITION

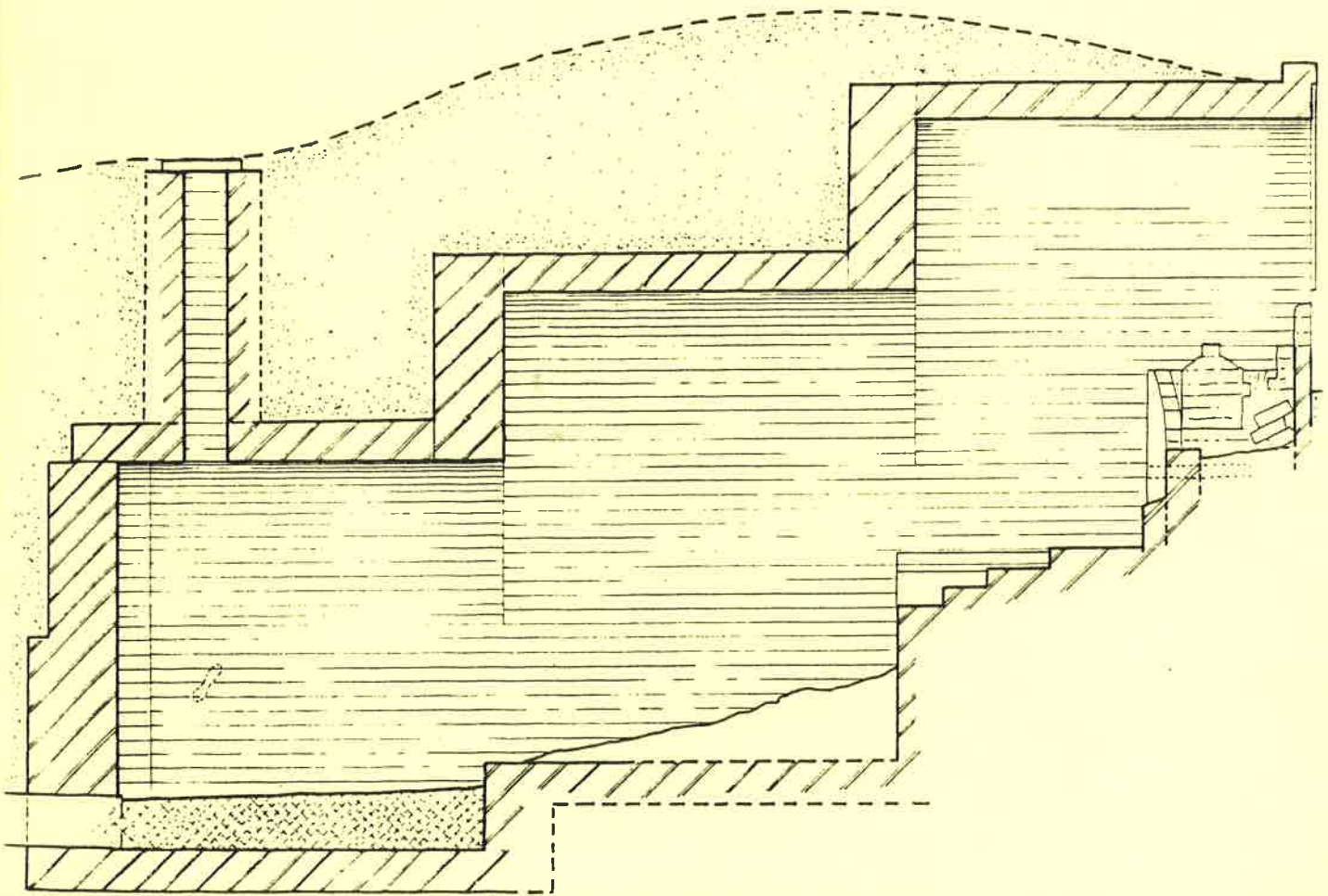

OXFORD ARCHAEOLOGICAL UNIT
OCTOBER 1998

Environment Agency

Berry Hill Ice-house, Maidenhead, Buckinghamshire
ARCHAEOLOGICAL RECORDING IN ADVANCE OF DEMOLITION

NGR: SU 9070 8132

Prepared by: *Jonathan Gill*

Date: 16 October 1998

Checked by:

S. Hoare

Date: 16 October 1998

Approved by:

Julian Munby

Date: 16 October 1998

OXFORD ARCHAEOLOGICAL UNIT
OCTOBER 1998

Berry Hill Ice-house, Maidenhead, Buckinghamshire

ARCHAEOLOGICAL RECORDING IN ADVANCE OF DEMOLITION

LIST OF CONTENTS

Summary

- 1 Introduction
- 2 Methodology
- 3 Background
- 4 Berry Hill ice-house
- 5 Conclusion

Bibliography

Appendix 1 Photographic register

Figure 1 Site location

Figure 2 Stepped plan and sections

Berry Hill Ice-house, Maidenhead, Buckinghamshire

ARCHAEOLOGICAL RECORDING IN ADVANCE OF DEMOLITION

Summary

The ice-house within the grounds of the former Berry Hill House is a well preserved nineteenth century structure to be demolished in advance of the Environment Agency's Maidenhead, Windsor and Eton Flood Alleviation Scheme. It is a relatively modest, brick ice-house, consisting of three square plan, barrel vaulted chambers, with a ventilation shaft between the lowest chamber and ground floor level. Due to the local importance of the feature, and the previously small amount of research undertaken on it, a programme of archaeological building recording was undertaken prior to its removal.

1 Introduction

- 1.1 The Oxford Archaeological Unit has been commissioned by the Environment Agency to undertake a programme of archaeological building recording on an ice-house associated with the former Berry Hill House, prior to its demolition as part of The Maidenhead, Windsor and Eton Flood Alleviation Scheme (MWEFAS). The national grid reference of the ice-house is SU 9070 8132.

2 Aims and Methodology

- 2.1 The aim of the project was to provide a record of the ice-house, as comprehensive as possible, in advance of demolition. The record aims to document the construction, structural form and present condition of the ice-house as well as interpreting the structure and placing it in the context of the overall development of ice-houses in Britain. Thus, a programme of measured drawings was undertaken using hand survey techniques, drawn on site at scale 1:20, including a plan, a long section and two cross sections. The initial field work was undertaken on 8 and 9 July 1998. An archaeological watching brief was also undertaken on 5 October 1998, when the ice-house was being demolished. The second stage of field work was intended to record features obscured when the ice-house was intact.
- 2.2 Prior to commencement of the survey it was necessary to clear the ice-house, particularly the lower two chambers of debris, which had accumulated due to the structure being used, apparently for some decades, as an informal rubbish dump. It was also necessary to remove some minor ivy and other vegetation, which was obscuring the entrance, to allow a clearer record of the structure to be made. Thick vegetation prevented an accurate survey of the outline of the mound but it was walked over to investigate the possible presence of features.

3 Background

The site

- 3.1 The ice-house is located on the eastern edge of Maidenhead and *c* 0.9 km to the south of Taplow. The site was not listed in the County Sites and Monuments Record, as quoted in *The Study of the Archaeological Implications of the Maidenhead, Windsor and Eton Flood Alleviation Scheme* produced in 1990 (BCM, 1990). However, another feature listed as 'ruined post-medieval ice-house', is included *c* 700 m to the north at SU 9056 8192. This is the ice-house associated with Taplow Court and is now evidenced only as a mound (Beamon and Roaf, 1990).

Berry Hill

- 3.2 The grounds at Berry Hill, within which the ice-house is situated, were laid out between 1856 and 1860 by John Marnock, the estate having been purchased by John Noble in 1855. The rectangular shaped estate, which had previously formed part of Taplow Court estate, is located on the south face of Taplow Hill and is enclosed by public roads to the north (Mill Lane), south (Bath Road) and east (Berry Hill), with fields to the west. Included in the landscaping was the creation of an artificial lake, known not to have existed in 1855, to the north of the (probably later) ice-house. The modestly sized country house, which has now been demolished, was sited on the eastern edge of the estate, about half way down the site, and *c* 30 m north-east of the ice-house. Its former location can be identified by a modern block of flats which now stand on the site. The house and park laid out at Berry Hill forms part of a wider mid-nineteenth-century development to the east of Maidenhead. Also forming part of this was neighbouring Taplow Court, dating from 1855 and also constructed with an ice-house, referred to above. (English Heritage Draft Register of Parks and Gardens).
- 3.3 There appears to be the remains of another ice-house within the grounds of Berry Hill, in the light woodland on the west bank of the lake. There remains a partially intact, brick, domed structure with a circular inner chamber slightly below ground level. It has the classic form of an ice-house, although of a different form to the one in this study, and was not investigated further as part of this project.

Ice-houses

- 3.3 Ice-houses are a building type distributed widely throughout the world with their origins stretching back thousands of years. In Britain, although there is evidence that the Romans constructed some ice-houses and that a few were built in the thirteenth and fourteenth centuries, it was not until the early seventeenth century that they became a common feature in the country mansions of the very wealthy. They continued to become more widespread in the seventeenth and eighteenth centuries and by the late nineteenth century

even the working classes could afford ice products. The demise of many ice-houses dates to the First World War, resulting from shortages of staff on the country estates and the sudden reduction of imported Norwegian ice, which by then was commonly used to fill the houses.

- 3.4 The general principal was that the structures would be filled with ice in the winter (supplied initially from a nearby lake or pond), with an insulating layer of straw placed between the ice and the structural shell. The house would then be sealed and only reopened in summer when the ice was required for preserving food, cooling drinks, use in desserts or medicinal purposes (Beamon and Roaf).

4 **Berry Hill ice-house**

- 4.1 Berry Hill ice-house consists of three barrel vaulted, brick walled chambers, each one at a lower level than the previous. The full length is 6.45 m and the width is *c* 1.81 m. The bricks used are generally yellow; many are frogged, and are of a rough, imperfect nature, with wide jointing. It appears from the brick bonding and from the section of vault visible from above that cavity wall construction has not been used in the structure. Each chamber is roughly square in plan, the highest principally being a porch and the lowest being where the ice was packed. The central chamber may possibly also have stored ice or may have been used to allow ease of access to the ice below.
- 4.2 The structure is notably intact, retaining its entire shell and with no substantial cracks in the structure, although the highest chamber is subsiding slightly away from the lower sections. Several steps appear to have been lost between the first and second chambers and some repointing has been undertaken, particularly in the vault of the first chamber, the cross face between the first and second chambers and in the curved rear wall of the third chamber. The original mortar is soft, contrasting with the later hard texture.
- 4.3 It is not an ostentatious ice-house, consisting of a simple brick arched entrance with projecting rim (cement render on top) and an earth mound with vegetation obscuring the main body. The first 0.3 m of the top of the brick tunnel entering the mound is visible. Along the inner rim of the entrance evidence can be seen of the former doorway sealing the ice-house. Towards the springing points of the arch there is a rough pattern of every other brick being slightly recessed, while towards the top there is a more constant indentation where every brick appears to have been slightly knocked off to allow a frame member to be wedged in. It is possible that the doorway would have been roughly bricked up each year and each corner of the base of the opening retains a few bricks from what would have been a larger sealing structure.
- 4.4 It is also possible that there were twin parallel doors to the entrance, possibly with an insulating layer in between. There is no clear archaeological evidence for this although it could be that this was an ephemeral structure leaving no trace.

- 4.5 A brick buttress topped by a header course exists to the west of the entrance, orientated perpendicular to the arch. The feature is flush with the inner face of the ice-house and its full extent is unknown, being covered by earth.
- 4.6 The ice-house is entered *via* a platform, 0.86 m deep, *c* 0.3 m below external ground level and 0.55 m above the floor height of the rest of the first chamber. The eastern half of the north edge of the platform curves slightly outwards. As existing the platform is hollow, containing a trench now full of debris, which was partially excavated as part of the project. There was presumably a surface over this trench. This was probably a set of steps, suggested by a small set of stepped bricks towards the front, which may once have formed part of a larger structure. The vault of the first chamber has a white residue, more pronounced than in the rest of the ice-house, with a green algae coating.
- 4.7 There is a ledge (secondary) on the west side of the platform, created from red bricks, contrasting with the yellow bricks used almost exclusively elsewhere in the building. The ledge is the perfect height and size for a seat and it is possible that it was added when the ice-house was no longer used for its original purpose. On the opposite side of the platform are the remains of another ledge which has been partially rebuilt with later yellow brick. The north wall of the platform, which traverses the upper chamber of the ice-house, rises to either side adjacent to the two seats, forming a semi-circular opening leading down to the lower chambers. The surface of this semi-circular edge is again rough suggesting the former existence of a set of steps, possibly similar to those between the first and second chambers, now destroyed.
- 4.8 A pair of small slot voids (*c* 0.14 m x 0.2 m openings, at least 0.6 m deep) exist within this platform visible in the northern wall. Their internal surfaces are rendered (at the entrance) and possibly formed part of the structure of a former step. A pair of cantilevered members may have projected from the slots supporting a timber step. Probably also forming part of this step is a central buttress with sloped upper surface, just below the line of the two slots varying in height from 0.23 m to 0.28 m.
- 4.9 The second chamber (2.3 m long) is reached from the first via a set of four brick steps which were completely obscured by general debris within the ice-house before the start of the recording work. The final step has a fall of *c* 0.85 m above the probable original floor surface, suggesting that several more steps no longer exist. It was impossible to remove all the debris from the floor of the second chamber and thus it is not known for certain whether the floor is completely flat or (as is probable) has a slight gradient to allow melted ice to drain into the lowest chamber.
- 4.10 The initial field work suggested that the ice-house had problems with drainage, an assessment put into doubt by the results of the watching brief. The possible problems were hinted at by an apparent drainage, (or water circulation) feature *c* 0.60 m to the east of the ice-house entrance. This is a square plan, brick-lined chamber with sloped rim, rising from 0.63 m to 0.90

m above ground. The feature appears to be of a slightly later date than the ice-house, with a distinctly different, grainy mortar. Two pipes enter the feature, to the north and east, each one now filled to half their height by earth and silt. The pipe to the east is of cast iron, with a 0.4 m diameter, while the one to the north is ceramic and with a diameter of 0.3 m.

- 4.11 There is no apparent physical connection between the feature and the ice-house, despite their close proximity, and the likelihood is that they are not related. A cast iron pipe takes water south (now with barely any flow), from the southern edge of the lake towards the ice-house, but appears to be directed slightly to the north of the ice-house, possibly towards the square plan drainage feature. It is possible that there is a connection, below the present level of silt in the feature, and that it was added to aid drainage after the ice-house suffered from water seepage. The watching brief, however, suggested that the ice-house would probably not have suffered from excessive damp, being well sealed and the surrounding land being relatively well drained. The walls and vaulted roof of the ice-house were shown to be very solid and not to have suffered much structural deterioration. It should be stressed, however, that good drainage was of absolute importance and even a relatively small amount of water seeping into the chamber could prevent the ice-house from functioning. Thus, even though the surrounding ground was gravel and appeared to drain well, it does not automatically mean that the inside of the ice-house was sufficiently dry.
- 4.12 A drainage problem affecting the ice-house was also initially suggested by the thick water/sludge raising the floor level of the lowest chamber. This sludge prevented a comprehensive survey of the full depth of this chamber during the initial field work and it was expected that this chamber descended a significant distance, possibly with a grill at the existing mud level to support the ice and allow water to drip away through a small drain at the bottom of the chamber.
- 4.13 However, a solid brick floor (3 courses deep) was revealed during the watching brief, 6 courses (*c* 0.48 m) below the floor level of the middle chamber with no evidence of a former grill to support the ice. There also did not appear to be a small drain at the base of the chamber, although the floor was well below ground level and due to health and safety reasons it was not possible to closely examine it. A cast iron pipe (diameter *c* 0.30 m) was revealed entering the chamber, immediately above floor level, at the central point of the curved end wall and continuing west towards the lake. Significantly, the pipe appears to gently slope down towards the ice-house and thus could not have been a drain to remove melted ice. When broken the pipe emptied a modest amount of stagnant water. The sludge within the chamber was clearly deposited via the pipe, rather than seeping in through the walls or rising from below, and was retained by the apparently well sealed walls of the ice-house. The watching brief also demonstrated that the ground surrounding the icehouse is relatively well drained (the local geology is gravel), despite the structure being towards the bottom of a slope and at the same height as the adjacent lake. A layer of puddling clay is sometimes added to the outer face of below ground ice-houses to improve the structure's water resistance but no such layer was revealed on this ice-house.

- 4.14 There is very little archaeological evidence within the walls of the ice-house indicating the former use of the structure. One exception appears to be a pair of similar indentations in each side wall of the lowest chamber. The one in the east wall is 0.25 m long, *c* 0.55 m above the level of the mud surface and *c* 0.1 m deep. Also of interest is what could be the remains of an iron brace in the cross wall between the first and second chamber to the eastern side. A piece of iron, which has clearly been distorted from its original shape, protrudes from the wall at this point and may once have supported something such as a small shelf for storing food.
- 4.15 The rear wall of the lowest chamber is curved (by 0.28 m at the central point) presumably with the intention of slightly increasing efficiency. It was recognised that the most efficient shape in reducing surface area relative to volume was the sphere and thus, with a barrel vaulted ceiling and curved rear wall the shape of the main chamber becomes slightly more spherical and less cuboid.
- 4.16 The ice-house at Berry Hill is typically nineteenth century, when quite varied but relatively modest forms were possible. Previously the standard section of the main chamber was egg shaped, located either entirely or partially underground and reached by a tunnel. Technological advances in the nineteenth century, together with a generally greater understanding of the scientific principles, resulted in many more square or rectangular shaped houses, such as that at Berry Hill, which were much easier and cheaper to construct (Beamon and Roaf, 1990).
- 4.17 The location and orientation of the ice-house are interesting, and possibly provide a clue as to the source of ice used. It is sited at the southern end of the lake, further away from the house to the north-east, when it would appear much more logical to be at the northern end of the lake, where it would be equally near a source of ice but closer to the house. The entrance is also facing away from the lake, which is again curious as this increases the distance over which the heavy ice would have to be carried. A possible explanation may be that the designer was more concerned with the structure being easily accessible from the adjacent Bath Road, since the entrance faces the road, *c* 10 m to the south. This would have allowed the ice-house to be most easily filled with imported ice transported by train, then by cart along the road.
- 4.18 Importation of ice from the United States and Norway developed rapidly in the first half of the nineteenth century, and it is quite possible that by the time of the construction of the ice-house at Berry Hill it would be assumed that most ice would be imported. This would make facing the road more logical than facing the lake, although the proximity to the lake would allow for flexibility.
- 4.19 It should be acknowledged that the orientation of the entrance, towards the south, may have been determined by other considerations, as in the nineteenth century there were conflicting opinions as to the most effective aspect for the entrance porch. Previously it had been assumed that facing north was most sensible, preventing direct sunlight entering the chamber, but an alternative

view gained ground suggesting that as damp was a greater threat than heat, facing south east would allow the sun to dry any damp collecting around the porch area (Beamon and Roaf, 1990). The majority of ice-houses do face north and whatever the reason for the orientation of the one at Berry Hill it is unusual in facing south.

- 4.20 One of the more interesting features of the ice-house, and one which helps to confirm its date to be mid nineteenth century, is the brick lined ventilation shaft (0.25 m x 0.23 m x 1.63 m high) rising vertically from the lower chamber to ground level. Prior to the 1840s it appears to have been assumed in Britain that an efficient ice-house had to be tightly sealed. This began to be challenged, largely due to exposure to differing practice from America, where the importance was appreciated of ensuring the release of noxious (and warm) fumes from rotting straw and of also of warm air generated by the melting ice. Ventilation shafts were sometimes also used to fill the chamber with ice and to remove it in summer. It is possible (although unlikely) that at Berry Hill the chamber may have been filled by this method but clearly impossible that the ice would have been removed through the narrow shaft.

5 Conclusion

- 5.1 This project has been able to record, prior to its demolition, a locally interesting structure which had previously been surprisingly unrecorded. The ice-house is neither listed in the Beamon and Roaf gazetteer of ice-houses, or in the County Sites and Monuments Record, or in the Berry Hill entry on the English Heritage's draft *Register of Parks and Gardens*. This is despite being located little more than 10 m from a main road between Maidenhead and Slough.
- 5.2 It is a relatively modest structure and can therefore be seen as a typically nineteenth century ice-house. Advances in technology had expanded the variety of ice-house forms possible and allowed smaller structures in more modest park grounds. Its ventilation shaft is also indicative of nineteenth century date as, possibly, is its orientation towards the road, from where it may have been filled with imported ice. The clearest archaeological dating evidence is the age of the machine made bricks, which strongly suggests a mid/late nineteenth century origin.
- 5.3 The physical evidence appears to point towards the ice-house being part of the Berry Hill park and grounds laid out between 1856 and 1860 or added to it soon after. This is supported by the fact that John Noble had moved out of Berry Hill house by 1871, possibly bringing to a halt any continuing landscape developments. However, documentary and cartographic evidence of this period fails to mention or show the ice-house, which may suggest that it is a later addition, after Noble had left Berry Hill. The first edition 6 inch Ordnance Survey map (1875) does not mark the ice-house, unlike the one 600 metres to the north at Taplow Court which is labelled.

- 5.4 Particularly significant may be the 1874 sale particulars which describe the garden, mentioning by name rustic bridges, an ornamental boathouse, secluded walks, rockery work, and an ornamental lodge facing the High Street, among many other garden buildings. It would seem surprising that in an attempt to detail the garden's structures, for purposes of selling the property, the ice-house was not felt worthy of even a brief mention. A deeper level of documentary research was not required by this project, the primary purpose being to record the structure prior to demolition, and further study of maps other primary sources should be able to shed further light on its date.
- 5.5 Interpretation of the structure's apparent drainage features is confusing and inconclusive. Preliminary interpretation, prior to the structure's demolition, was that that the ice-house suffered from drainage problems (explaining the sludge layer inside) and that the small square planned sump was then added. The watching brief showed that the area around the ice-house was relatively well drained and that the sludge was brought into the chamber by the cast iron pipe, integral to the construction. The pipe would make reasonable sense if it was draining away from the ice-house, removing melted ice, but it appeared to slope down towards the ice-house.
- 5.6 A possible (unlikely) interpretation is that the pipe was installed to allow the ice-house to partially fill with water in autumn, which it was hoped would then freeze in winter and remain frozen until summer. If this was the intention, it seems probable that it could only have worked in the most severe of winters, as the energy required to freeze a large amount of water is much greater than that required to stop a large amount of ice from melting.
- 5.7 Another improbable possibility raised is that in fact the structure was not an ice-house. There are enough classic ice-house features (mound, ventilation shaft, several descending chambers) to be able to assume that it was originally constructed as an ice-house but it is possible that it was then converted to another purpose such as a small pump house, which would partially explain the pipe entering the lowest chamber. The pipe appeared strongly to be primary, however, and not to have been inserted.

J Gill
Oxford Archaeological Unit
October 1998
CONS\C-DRIVE\oau\WS\Jonathan\Icehouse.doc

Bibliography

- Beamon S and Roaf S 1990 *The Ice-Houses of Britain*
- BCM 1990 *Study of the archaeological implications of the Maidenhead, Windsor and Eton Flood Alleviation Scheme*
Buckinghamshire County Museum
- BCM 1997 *A report on the Landscape History of the area along the Thames Flood Alleviation Channel between Maidenhead and Windsor*
- English Heritage 1998 *Register of Parks and Gardens (Draft)*
- Pevsner N 1960 *The Buildings of England: Buckinghamshire*
- Taigel A and Williamson T 1993 *Know the landscape: Parks and Gardens*
- The Garden* July 6 1872
- The Gardeners Chronicle and Agricultural Gazette* October 1860
- Ist ed 6 inch OS Map 1875*
- Project documentation including photocopied sheet summarising documents in County Record Office including Sale particulars of 1852 (Doc D/TR21); Sale particulars 1855 (Document D/GR/19/4); Sale particulars 1874 (Document D/GR/19/13); Bundle of letters (Document bundle D/GR/18/26);

APPENDIX 1 PHOTOGRAPHIC RECORD

Film 1 (Black and white print and colour slide)

Neg No	View from	Context
0	S'W	Front of icehouse
1	S	ditto
2	S	ditto
3	S	ditto
4	SE	ditto
5	SE	ditto
6	SE	ditto
7	SE	ditto
8	SE	ditto
9	SE	ditto
10	S	Internal - first chamber
11	S	ditto
12	S	ditto
13	S	ditto
14	SW	ditto
15	SE	ditto
16	S	ditto
17	N	Lowest chamber
18	N	ditto
19	N	ditto
20	N	ditto
21	NW	Middle chamber and steps/platform
22	NW	ditto
23	NW	ditto
24	NW	ditto
25	NW	ditto
26	N	ditto
27	NE	ditto



Plate 1: General view of ice house and mound

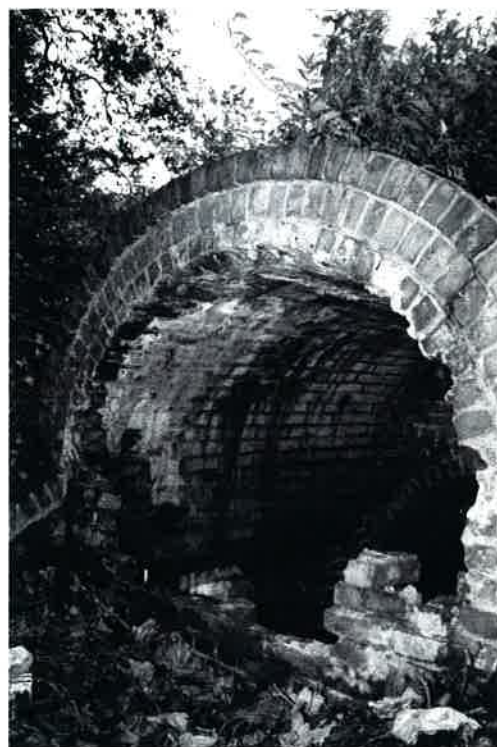

Plate 2: Entrance to ice house



Plate 3: Interior of ice house from upper chamber



Plate 4: Steps between upper and middle chamber

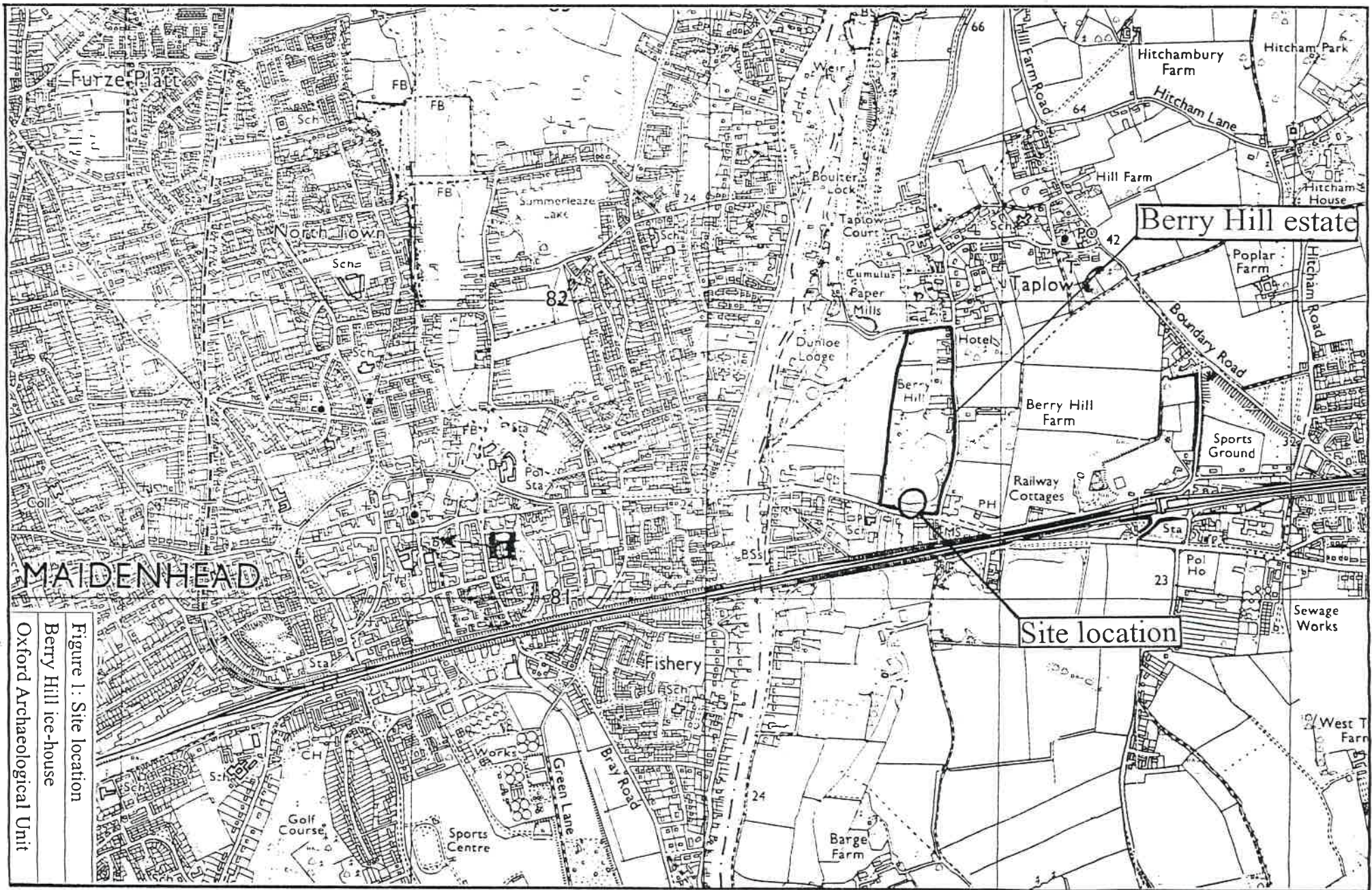
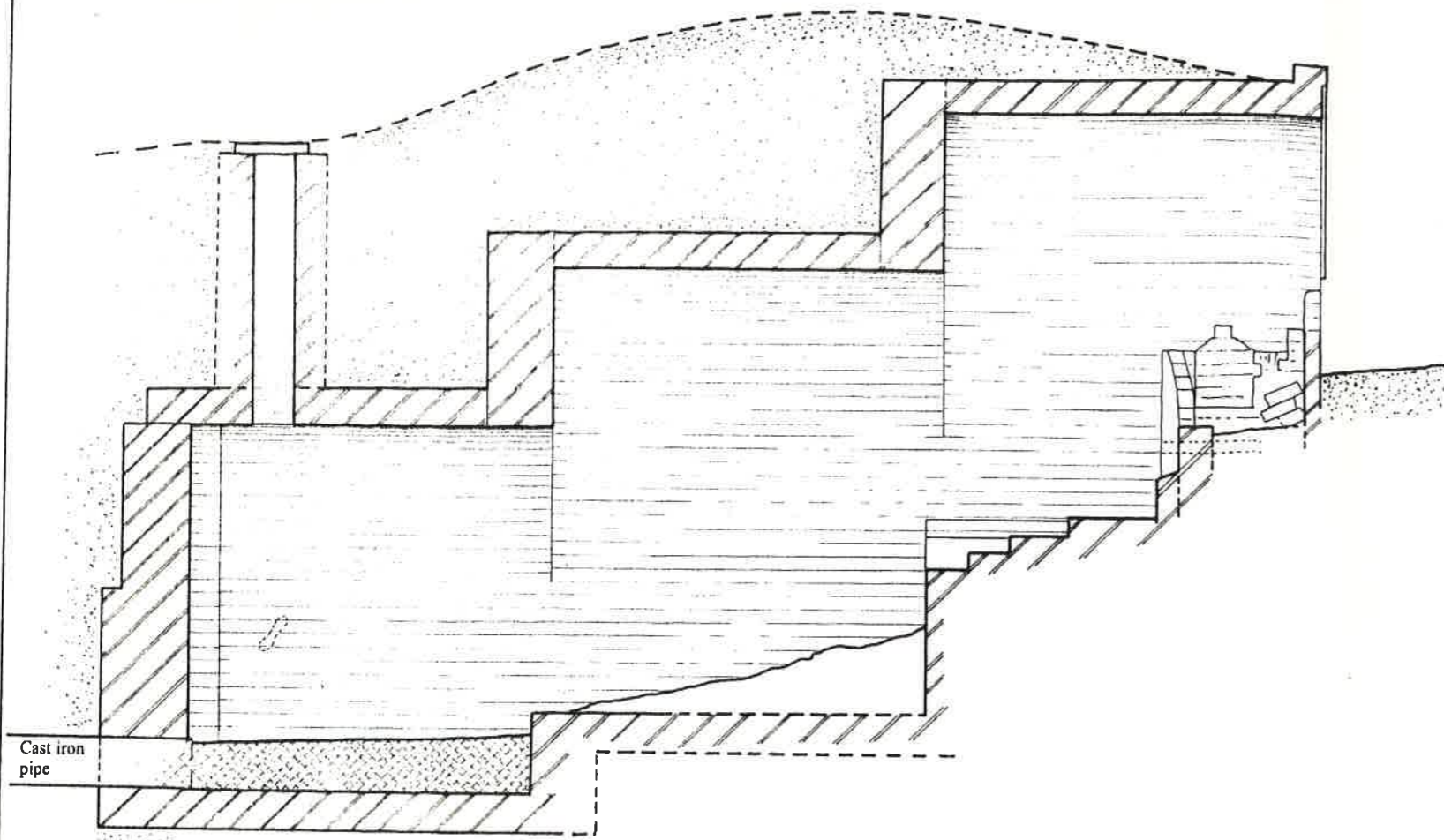
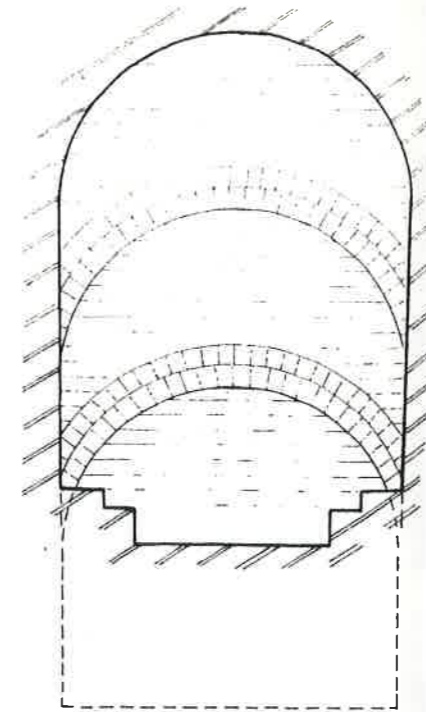

Figure 1: Site location
 Berry Hill ice-house
 Oxford Archaeological Unit



Section A-A'



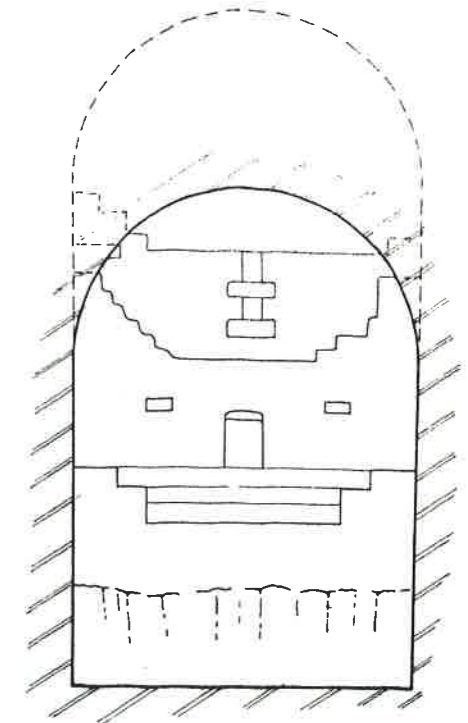

Section B - B'

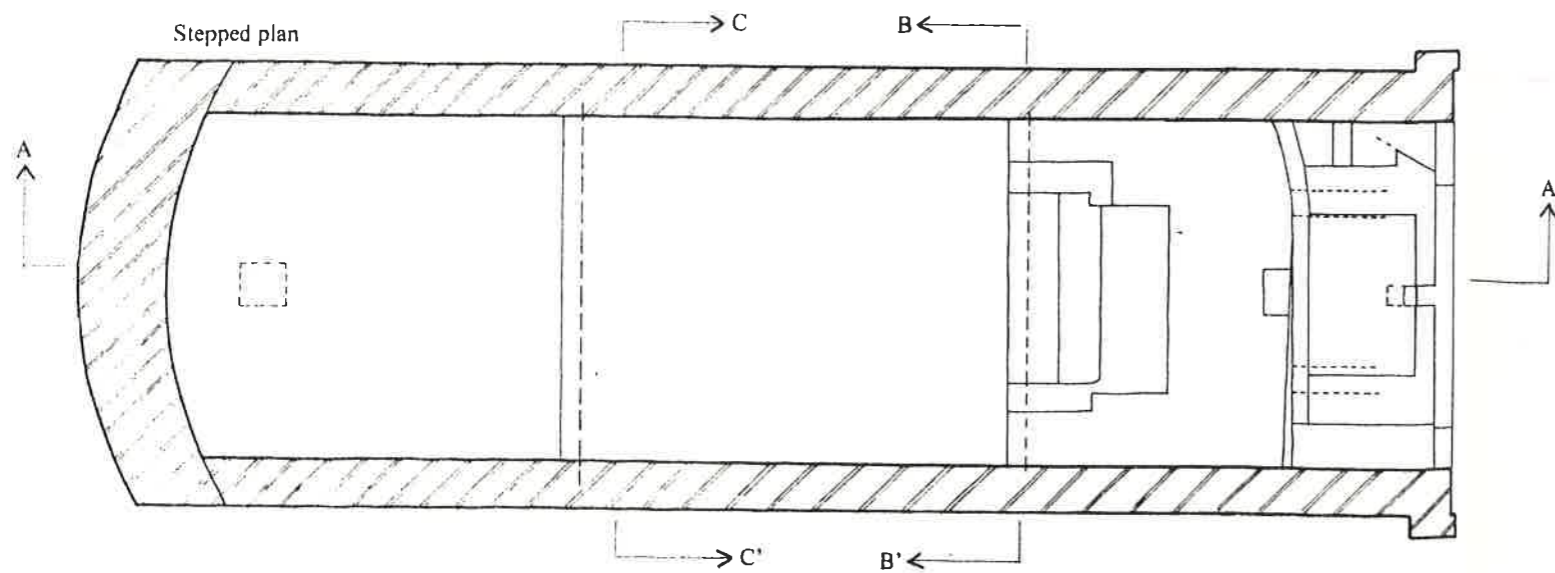
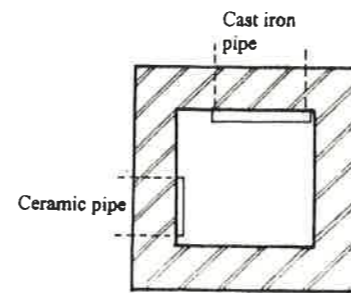

Section C - C'



-  Earth/ground
-  Sludge
-  Brick

0 1 2
Metres

Oxford Archaeological Unit

Berry Hill ice-house
Figure 2: Plan and sections

Scale 1:20 (at A1) July 1998

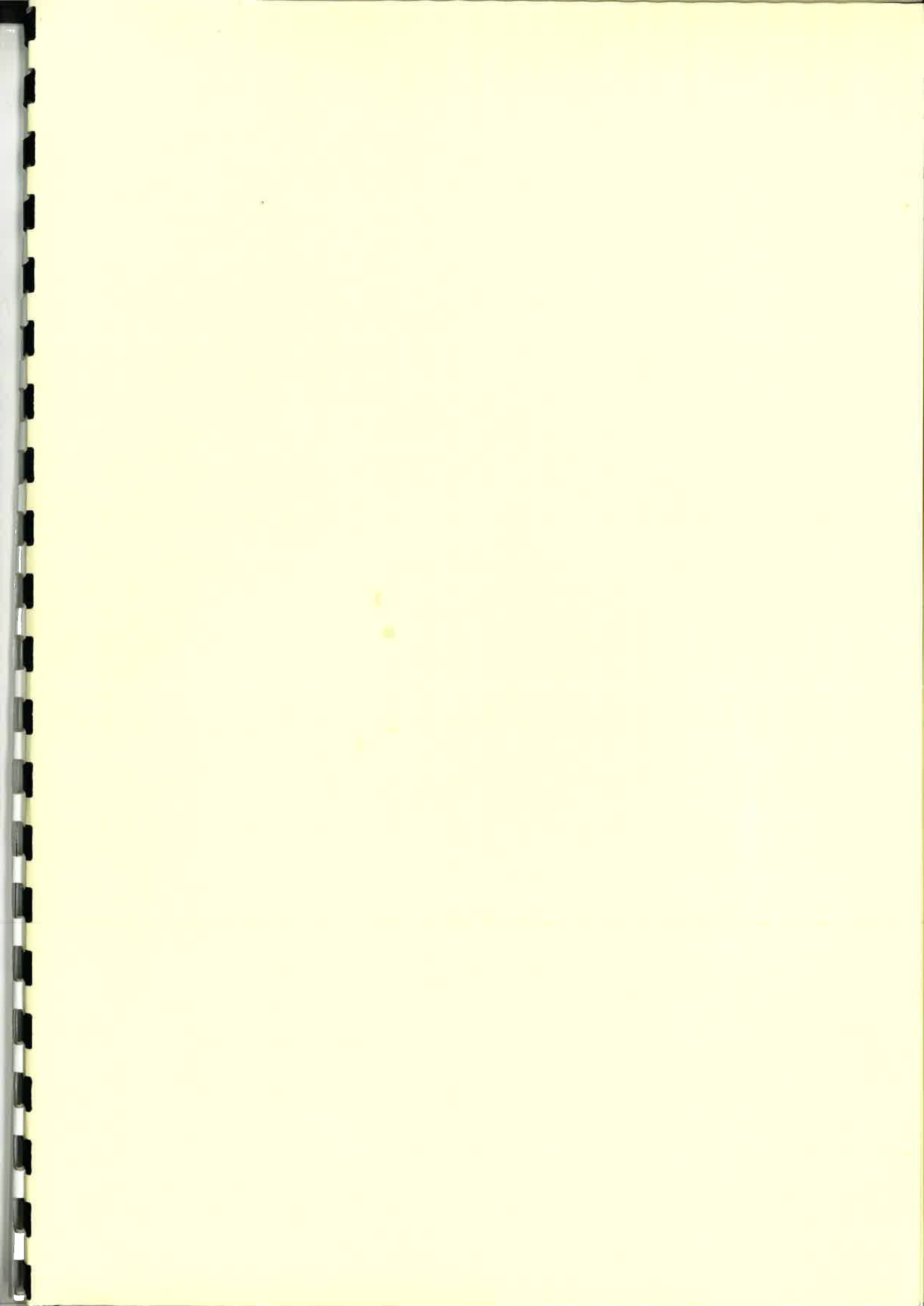



OXFORD ARCHAEOLOGICAL UNIT

Janus House, Osney Mead, Oxford, OX2 0ES

Tel: 01865 263800 Fax: 01865 793496

email: oau-oxford.demon.co.uk



Director: David Miles B.A., F.S.A., M.I.F.A. Oxford Archaeological Unit Limited.
Private Limited Company Number: 1618597 Registered Charity Number: 285627.
Registered Office: Janus House, Osney Mead, Oxford OX2 0ES